

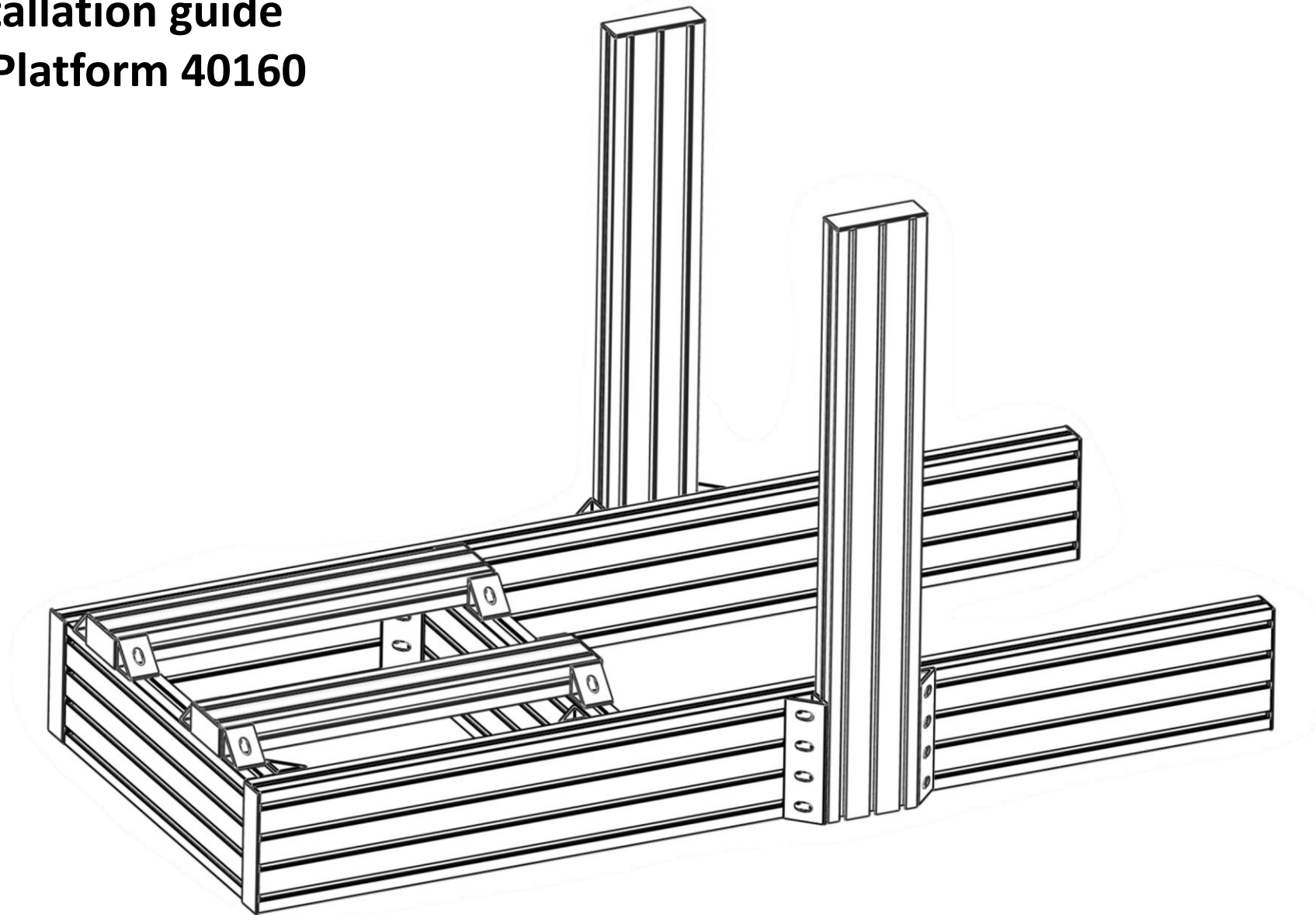

# Quick installation guide

## VNM Rig Platform 40160



**1** 40x160x1350  
x2

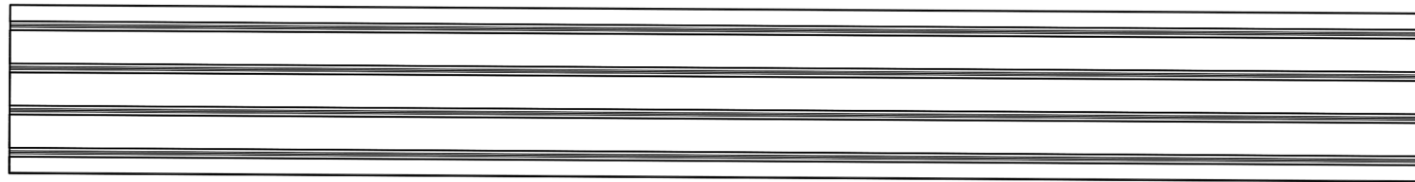

**2** 40x160x500  
x2



40160 Conner Alu  
x8

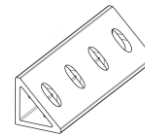

40160 Alu Cover  
x4



Rubber foot  
x4



**3** 40x120x780  
x2

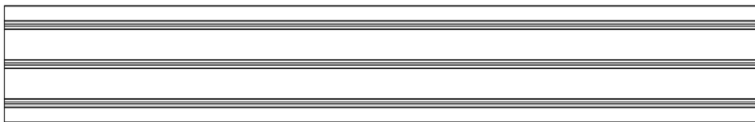

**4** 40x80x500  
x2



4040 Conner Alu  
x8



40120 Alu Cover  
x2

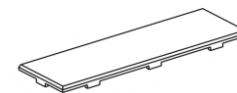

4080 Alu Cover  
x4

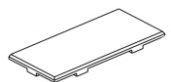

M6x20  
x4



T Nut M6  
x4

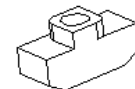

M8 Slider  
x80

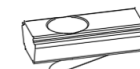

M8x16  
x80



*If you are missing any parts, please contact our customer support team who can assist!*

## Method 1

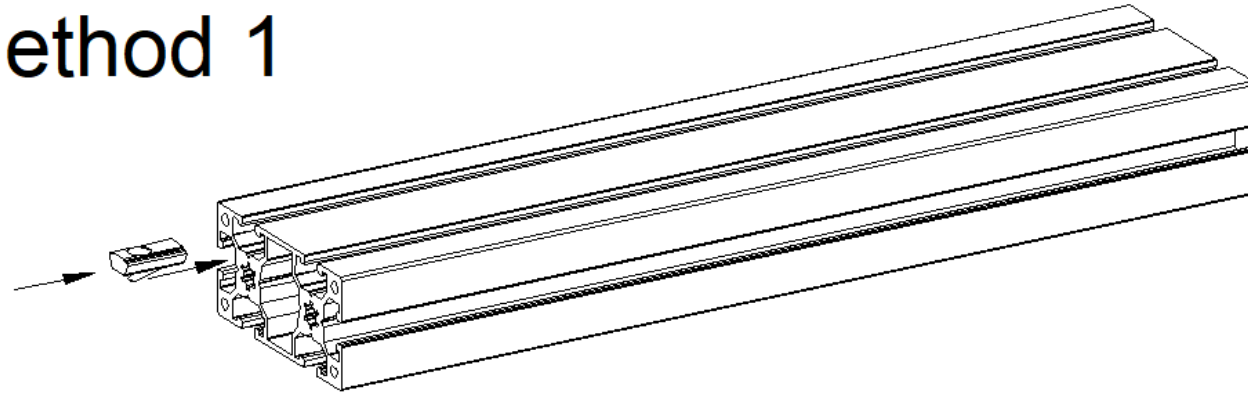

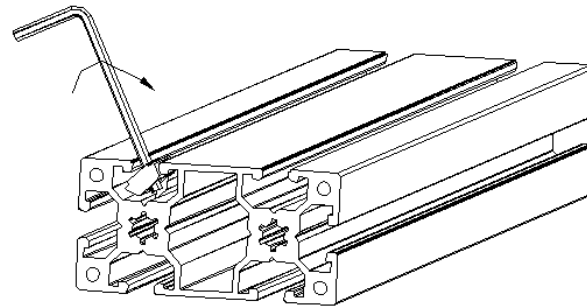

## Method 2

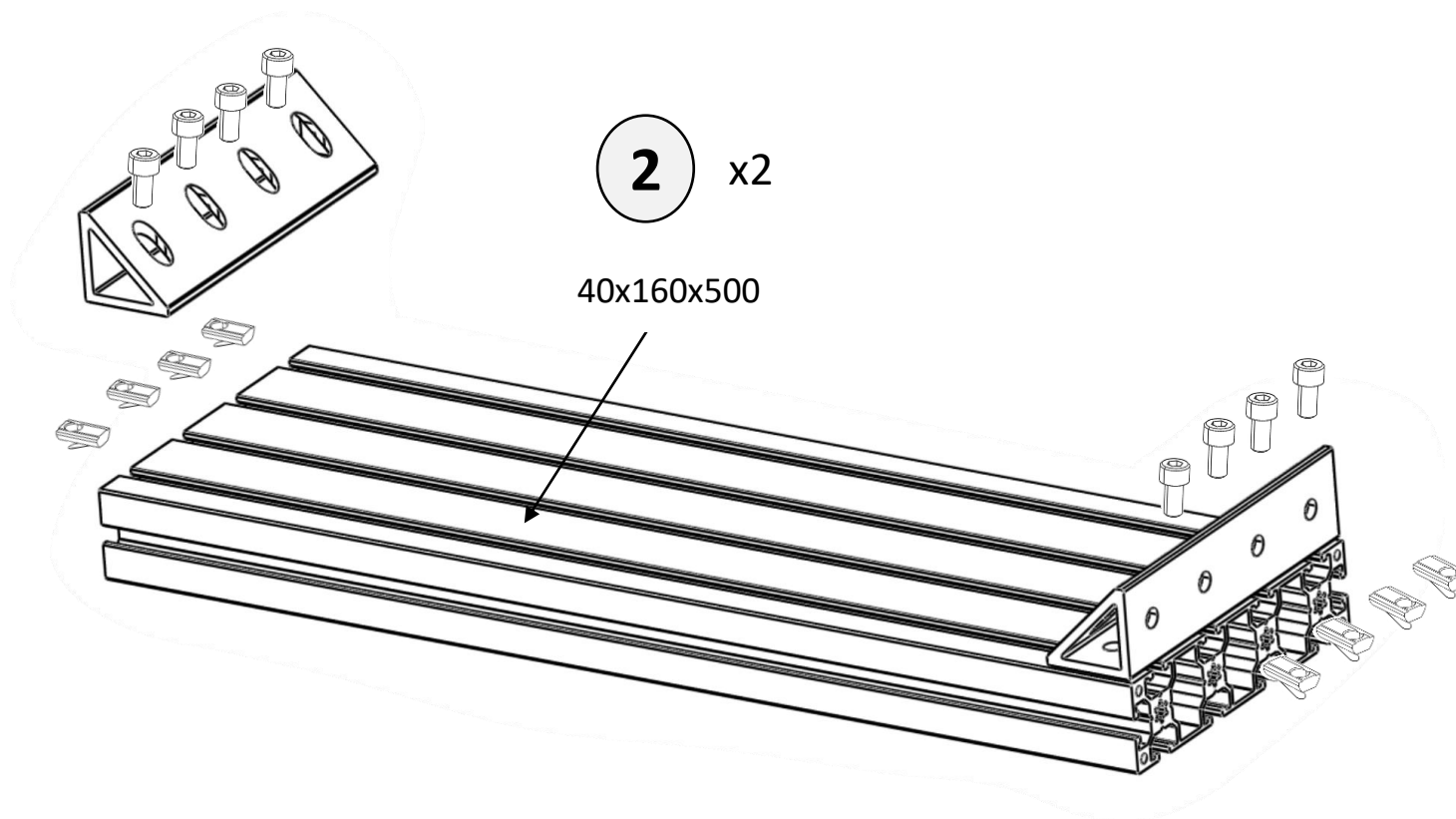
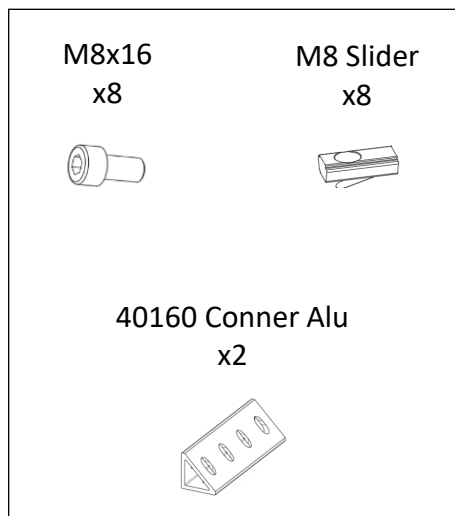

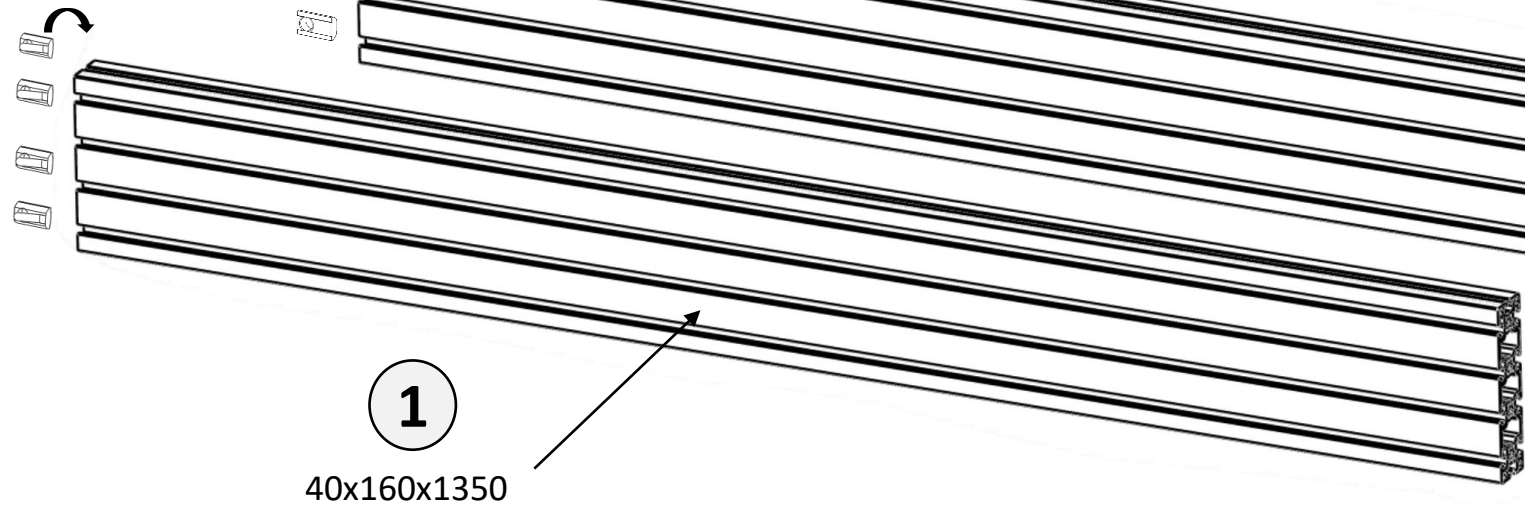
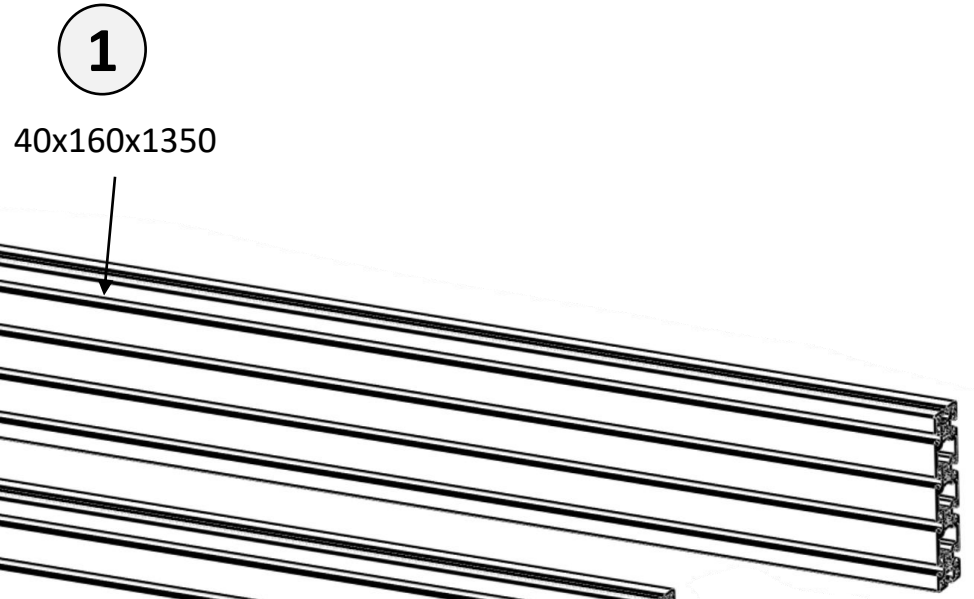
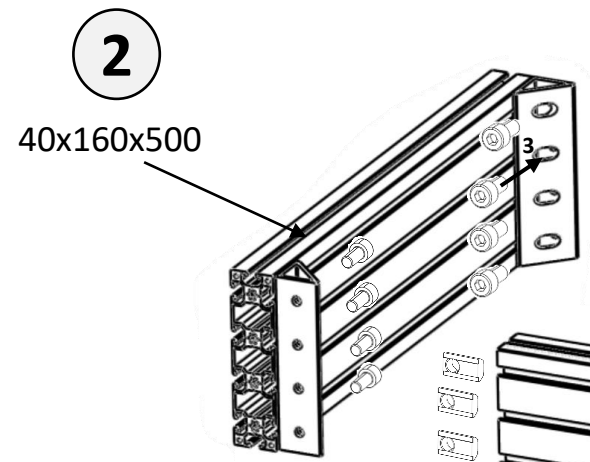



M8x16 x8	M8 Slider x8
	

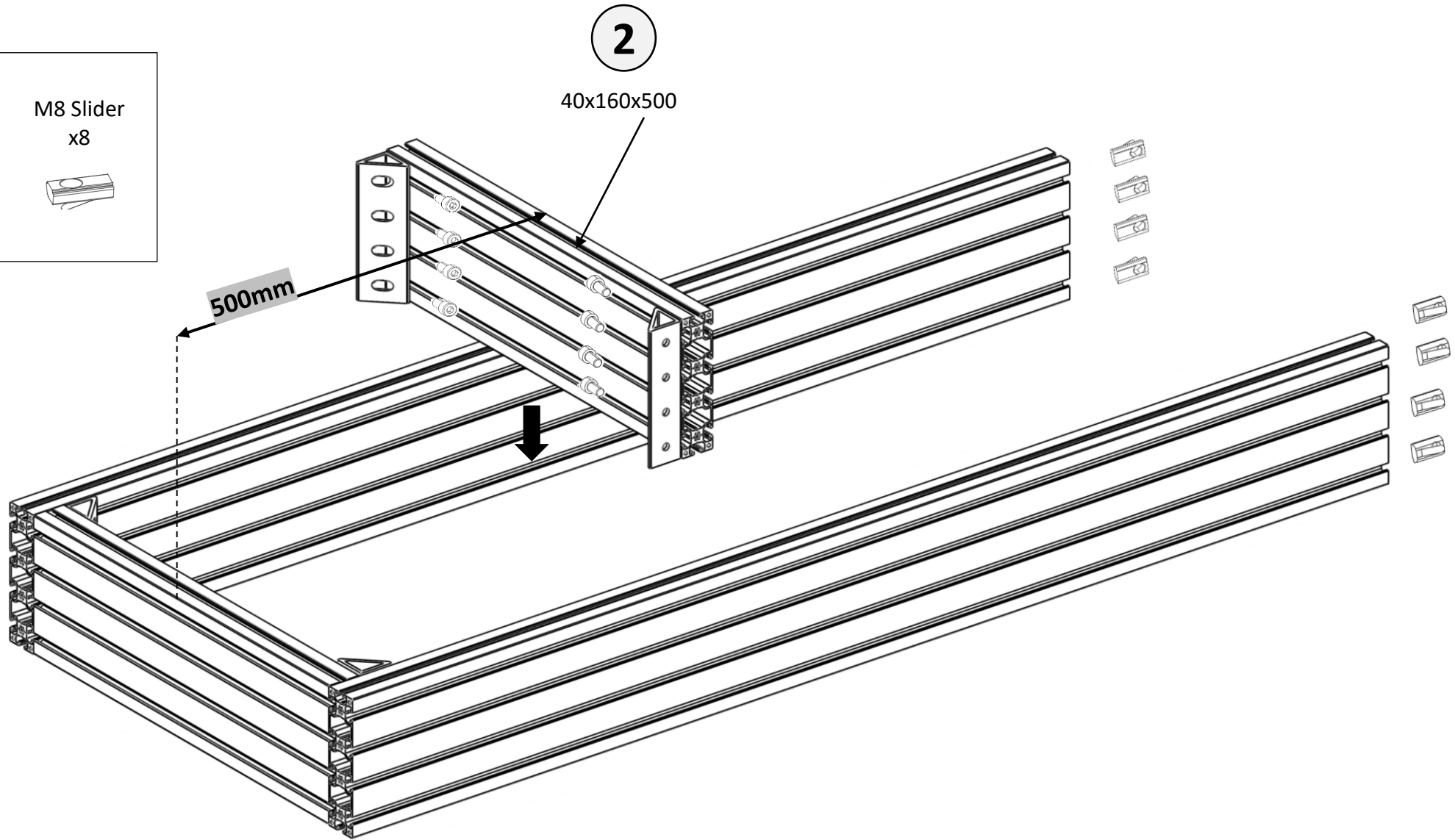
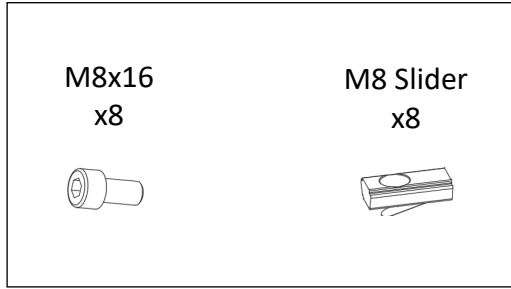

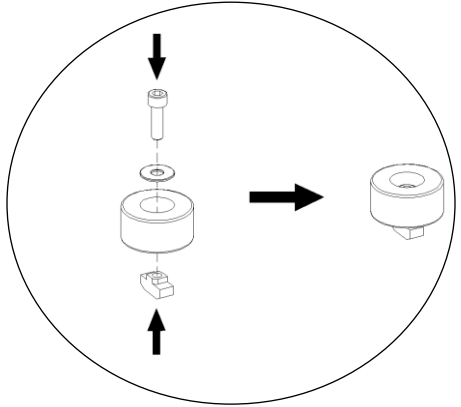
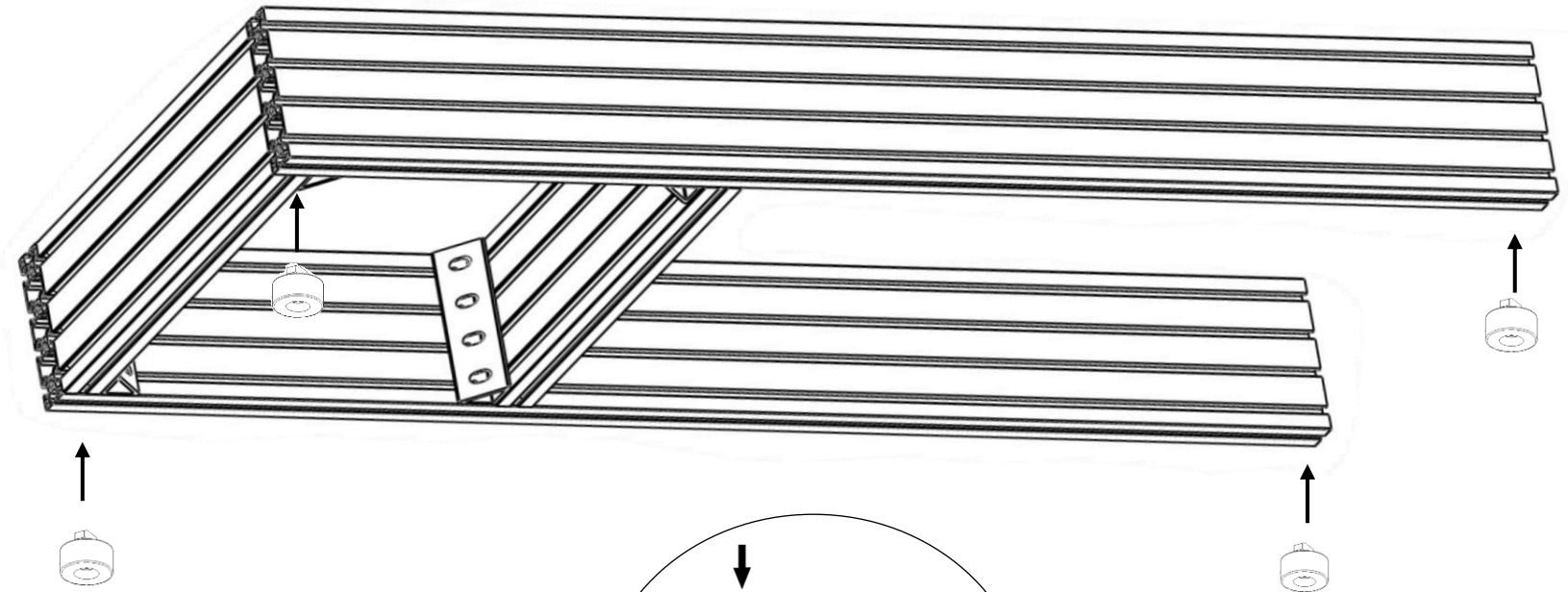
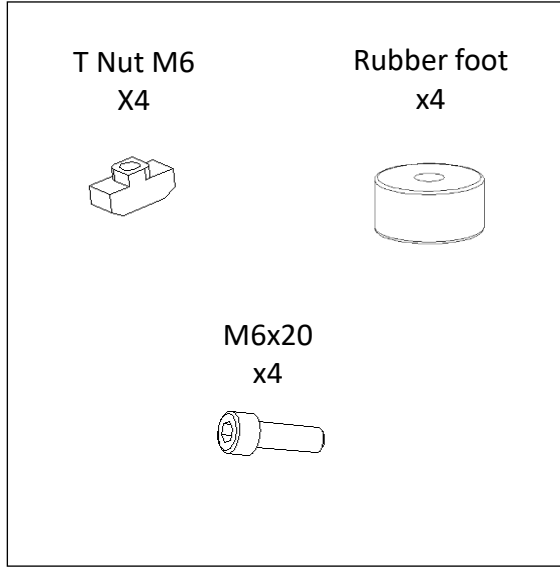

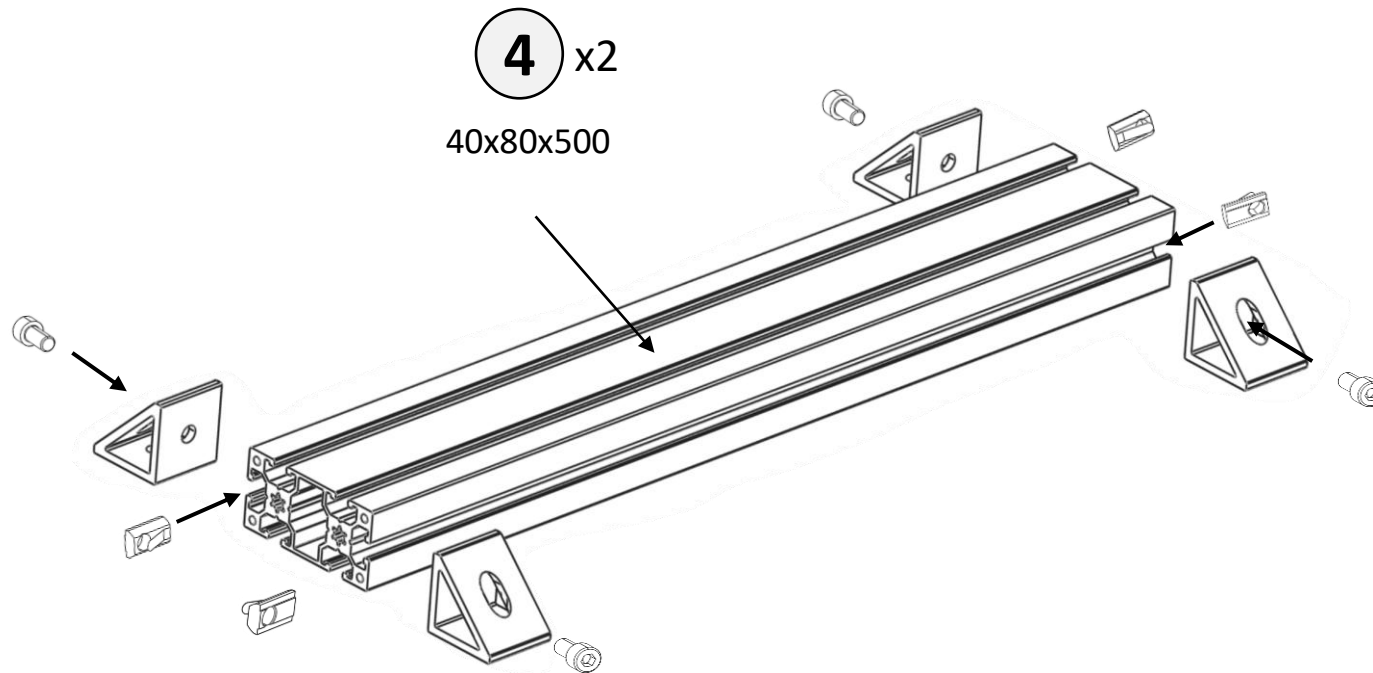
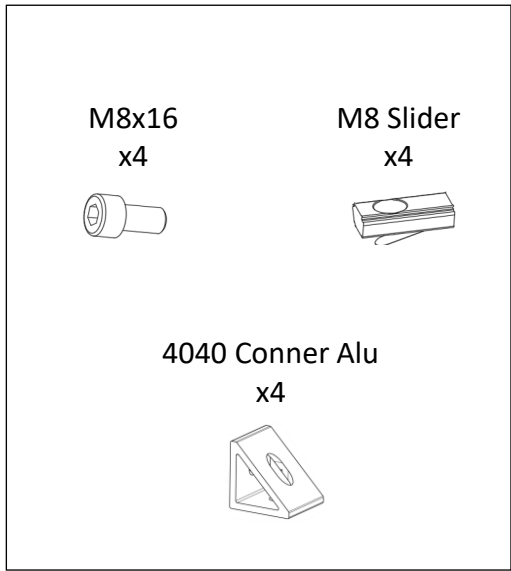

**Note:** After adjusting the positions of the profiles as needed, you may fully tighten the M8 and M6 bolts.

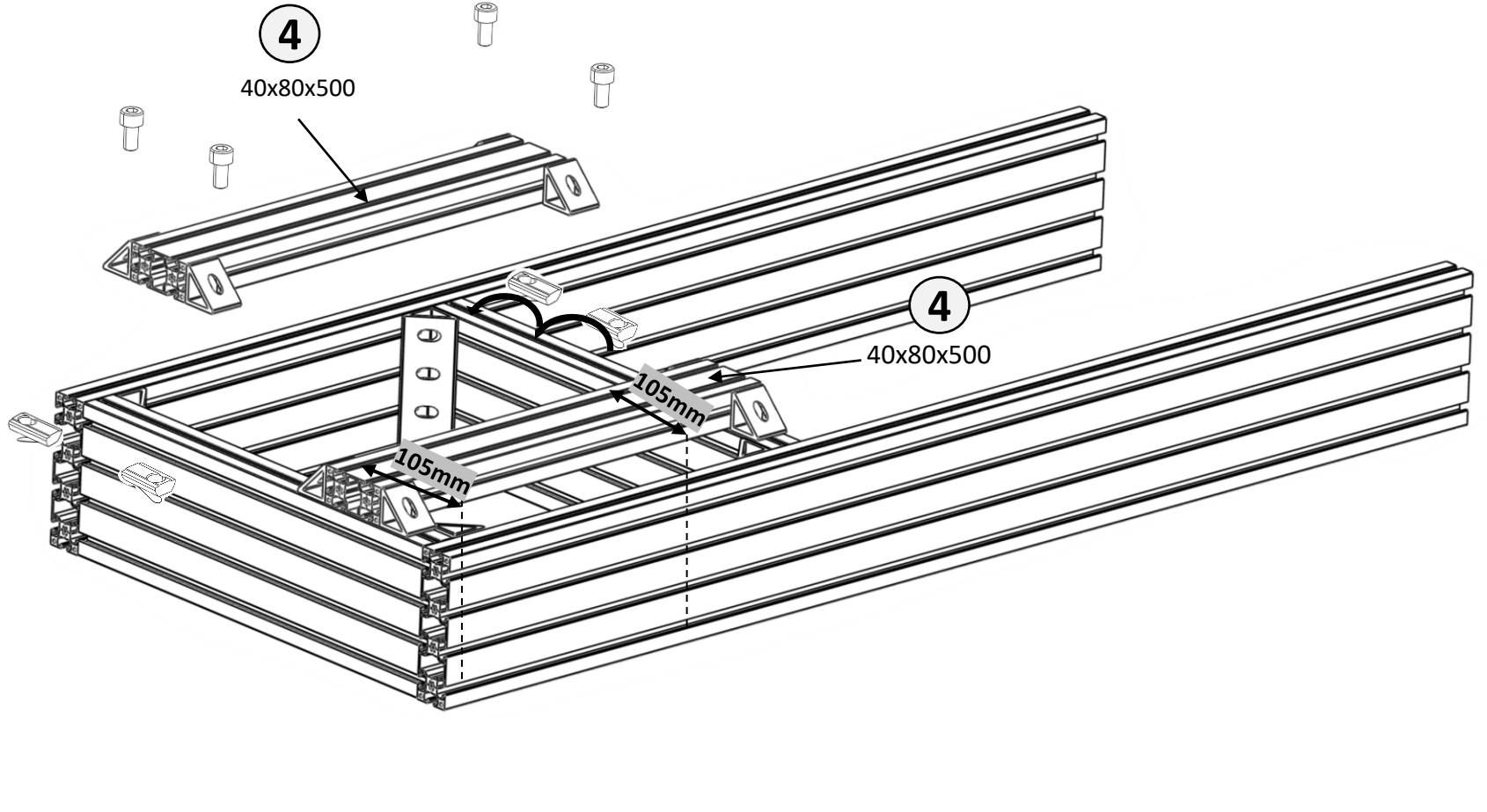

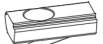

**Note:** After adjusting the positions of the profiles as needed, you may fully tighten the M8 bolts.  
 Distance between 4080x50 and 40160x1350 profiles: 105 mm.

M8x16 x8	M8 Slider x8
	
40160 Conner Alu x2	
	

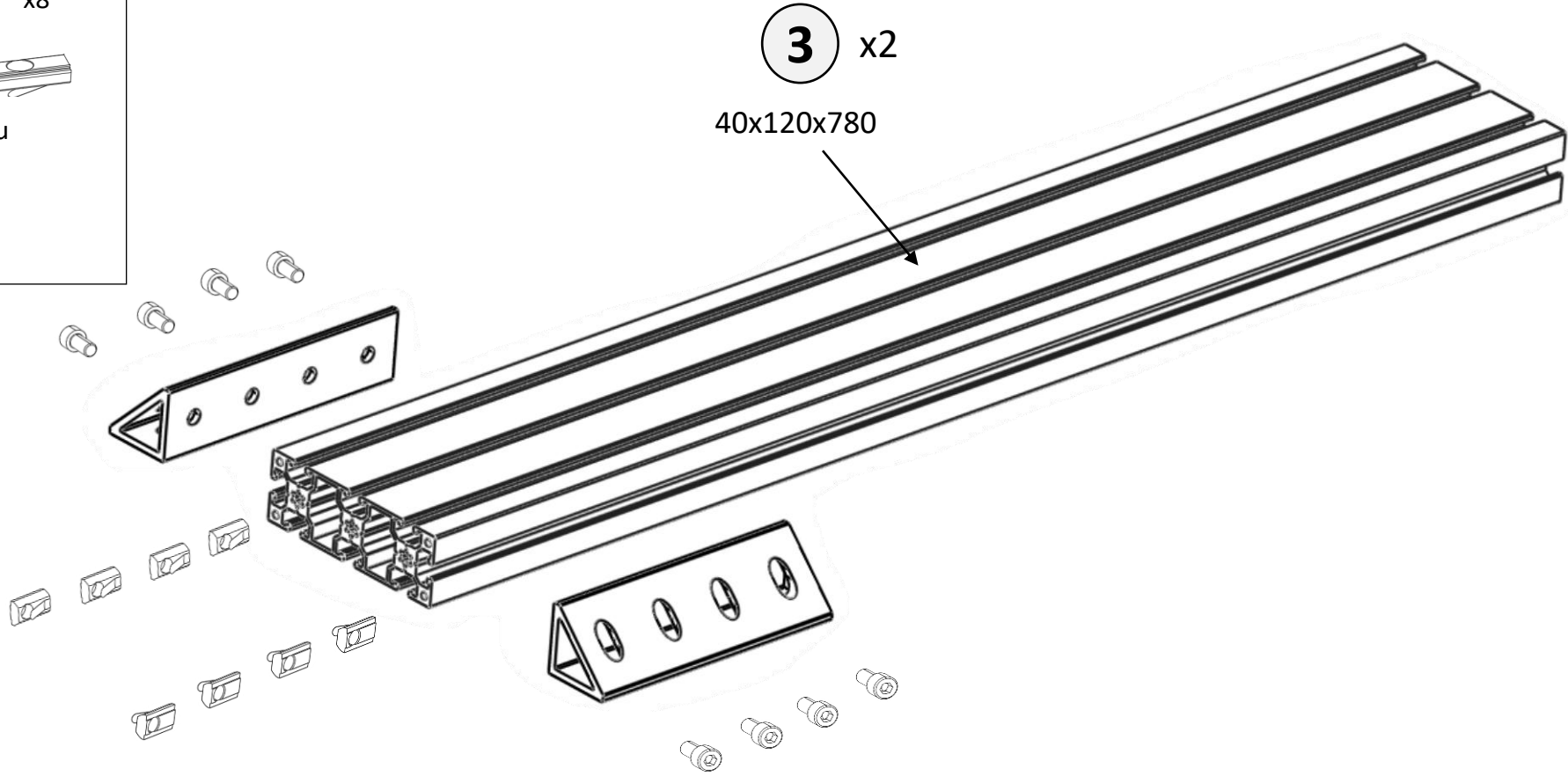

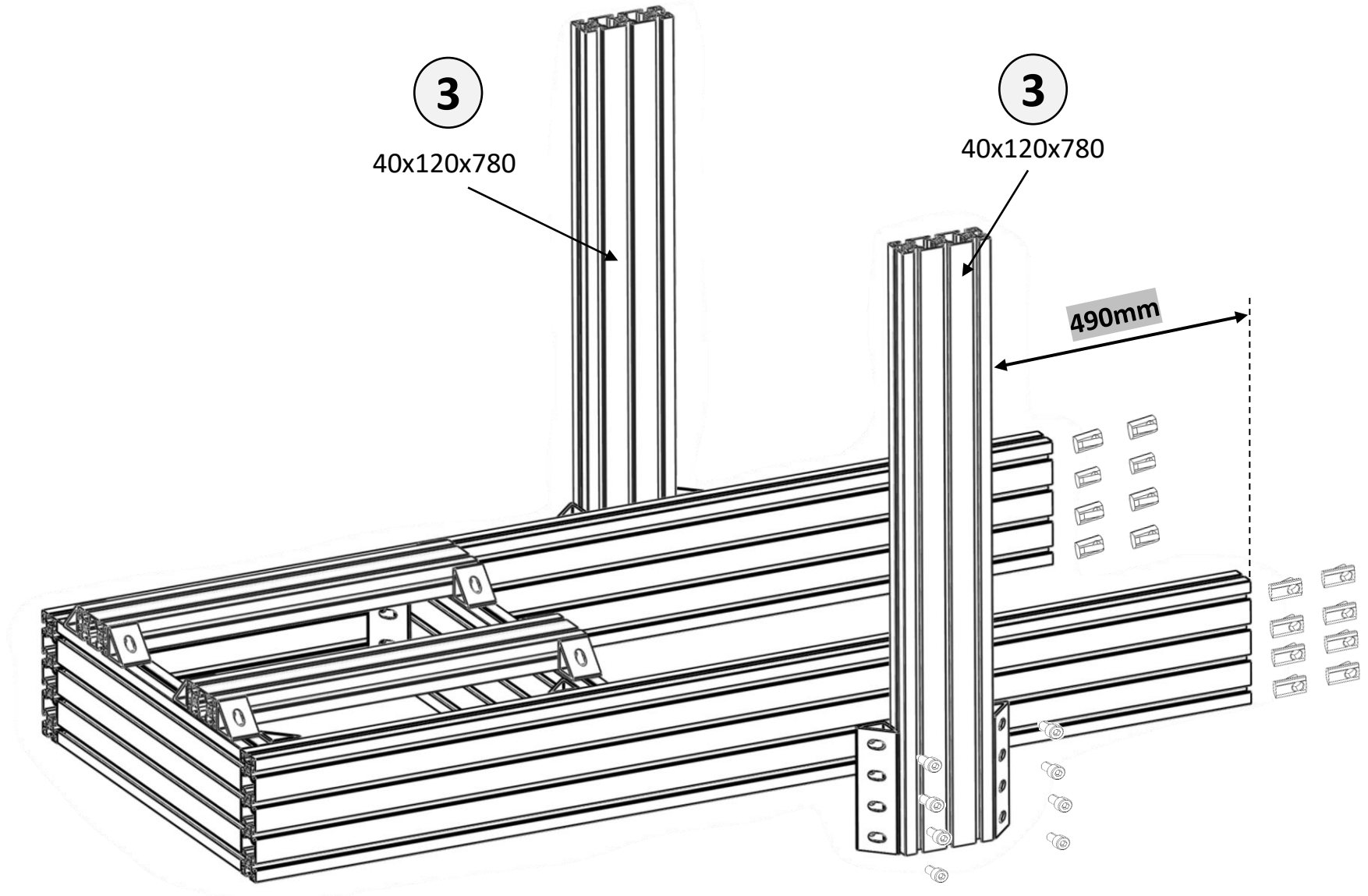

**Note:** After adjusting the positions of the profiles as needed, you may fully tighten the M8 bolts.  
Distance between 40120x780 and 40160x1350 profiles: 490 mm or as far as you can reach.

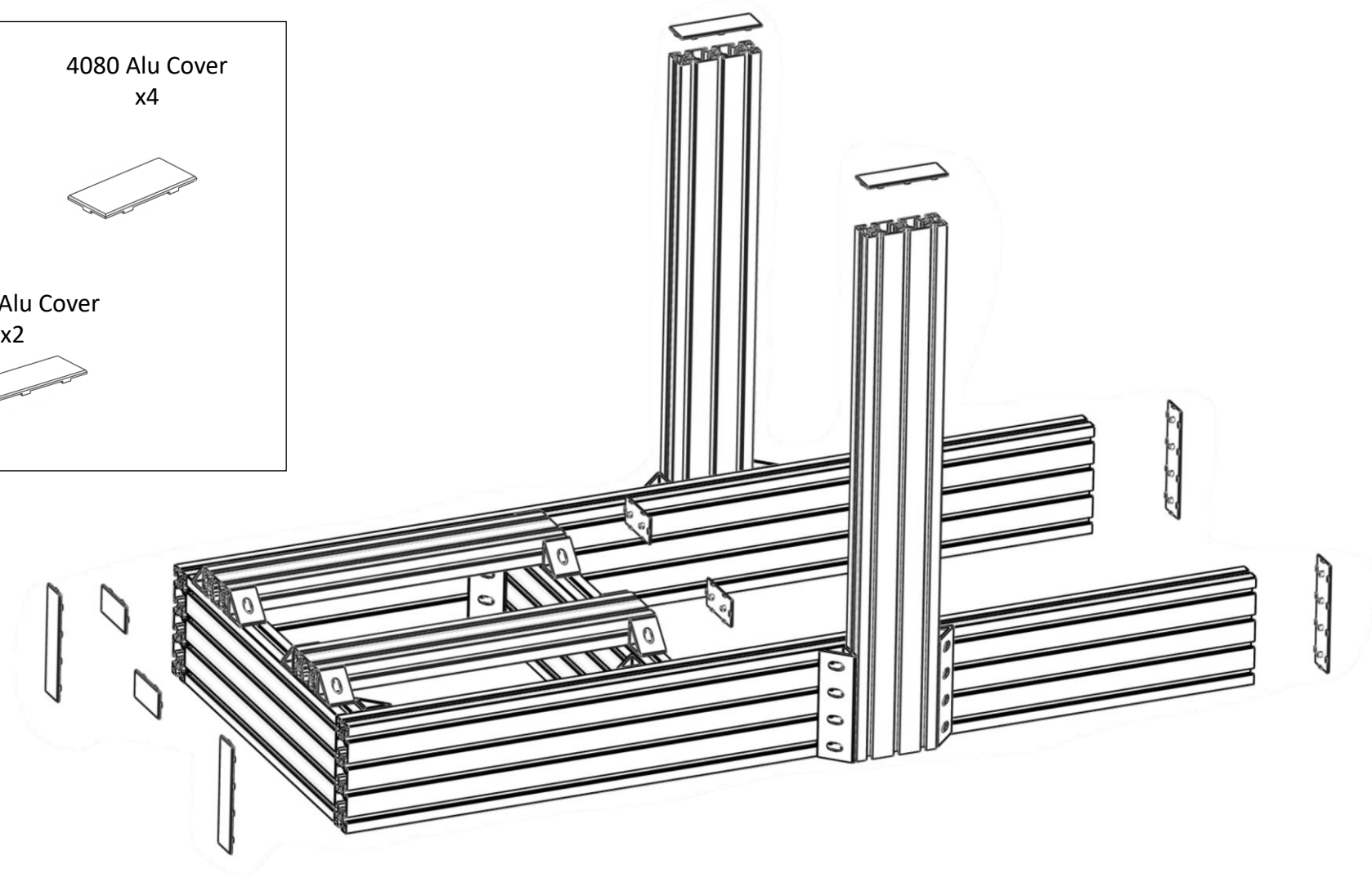
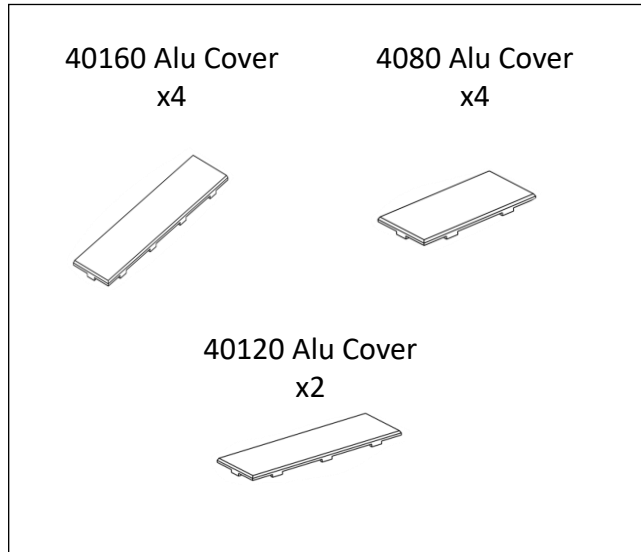

**Note:** After adjusting the positions of the profiles as needed, you may fully tighten the M8 bolts.

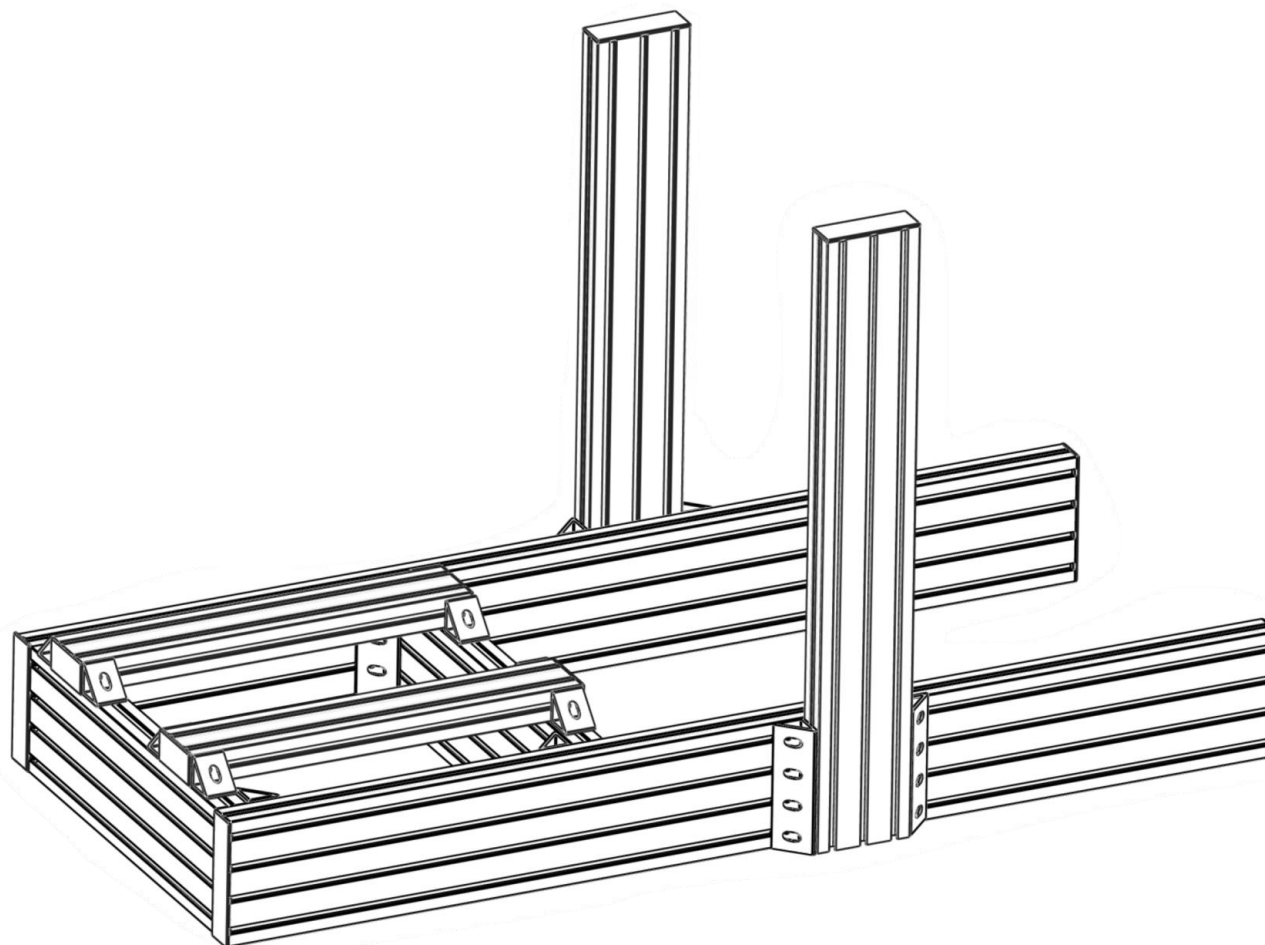

*“Congratulations on completing your rig assembly. If you have any questions or encounter any problems, please contact us for support!”*