

VNM LITE PEDAL

Quick Guide

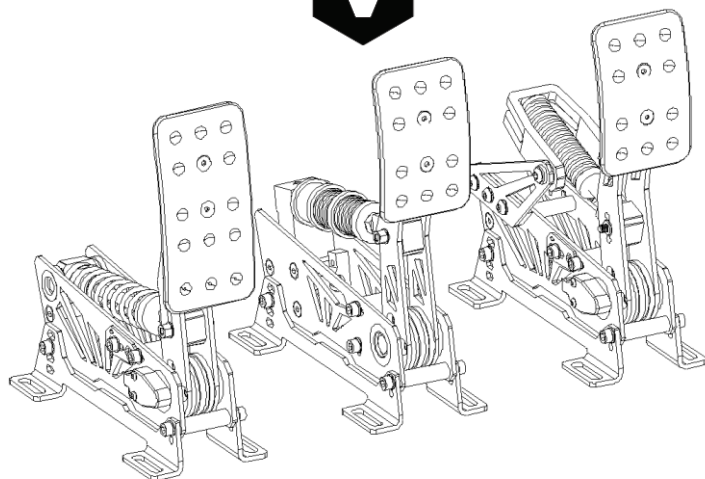

Content

1. VNM Throttle
2. VNM Brake
3. VNM Clutch
4. Pedal Controller Box
5. USB Cable type C
6. Allen key set & Mounting screws
7. 02 black, 01 yellow spring, and 01 elastomer

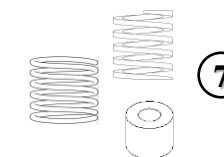
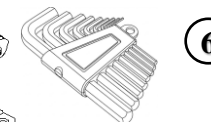
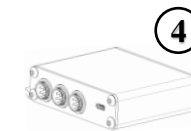
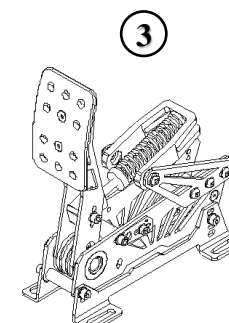
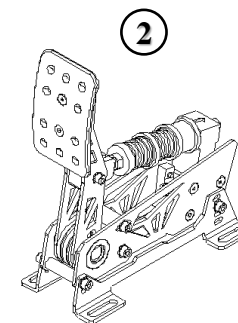
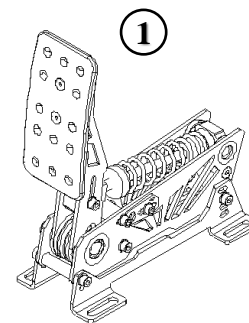

Connection

1. GX12 port for Clutch (non using in set 2)
2. GX12 port for Brake
3. GX12 port for Throttle
4. USB-C port to PC

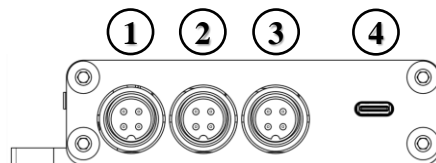

Right side of the VNM Controller Box

5. **DFU/Run Mode** switch.
*(Always make sure the controller is in **Run Mode**. DFU Mode is used for firmware updating only)*
6. CN 1 port
(Not currently in use)
7. HT1 port for Haptic 1
8. HT2 port for Haptic 2
9. HT3 port for Haptic 3
10. DC 24V power

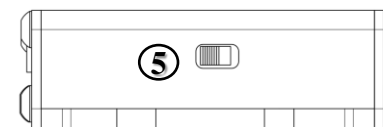

Bottom side of the VNM Controller Box

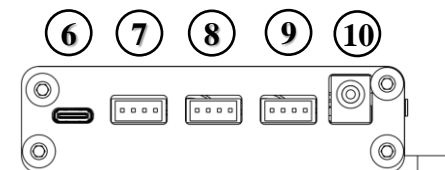

Left side of the VNM Controller Box

To **connect** the VNM Direct Haptic, simply plug it into one of the three ports: HT1, HT2, or HT3 on the VNM Controller Box

Disclaimer: Always plug the DC 24V power jack into the controller box **before** plugging it into an outlet

Adjust Pedal

1. Adjust the height of the Pedal face

- ✓ Loosen the 4 hex bolts on the sides behind the pedal face, choose a suitable pedal height, then tighten.

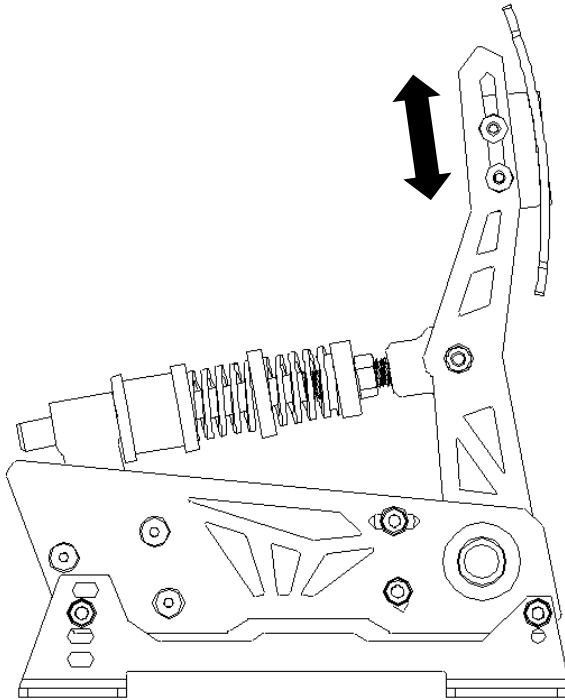

2. Adjust the Pedal tilt angle

- ✓ Here we give 8 options so you can change the angle of the pedal to your liking.
- ✓ Loosen the 2 hex bolts on the sides, then choose the angle that suits you and tighten them with the hex bolts.

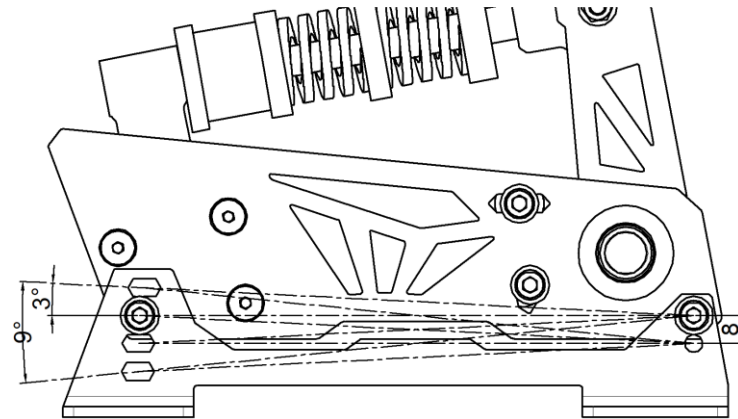

3. Adjust the Pedal Force

- ✓ Adjust the spring preload so that the pedal force is right for your foot

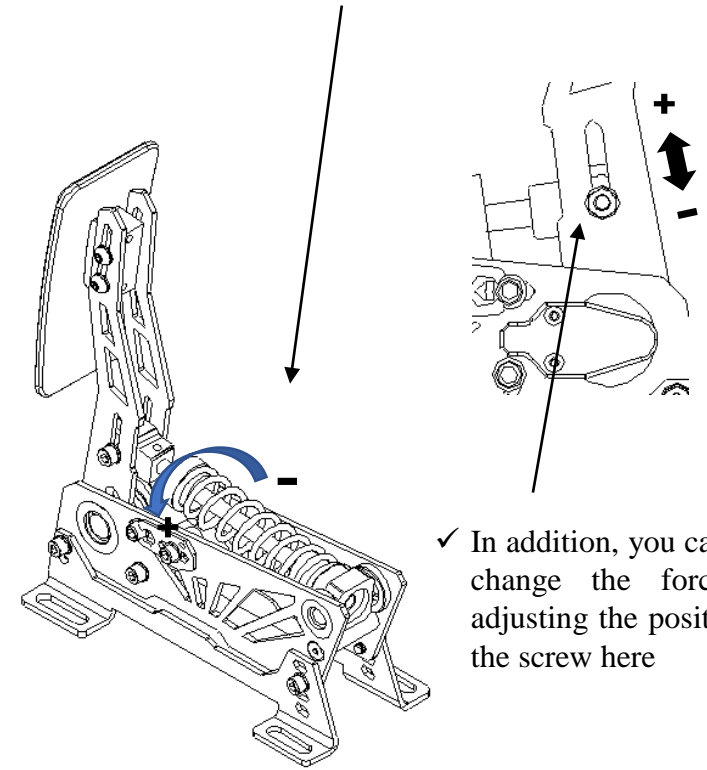

- ✓ In addition, you can also change the force by adjusting the position of the screw here

4. Adjust the Pedal Journeys

- ✓ Loosen the 2 hex bolts on the sides, adjust 2 blue bumpstops to change pedal stroke

Blue Bumpstop 1:
Move blue bumpstop to change pedal stroke limit.

Blue Bumpstop 2:
Adjust the inclination of the pedal face (pedal stroke start point)

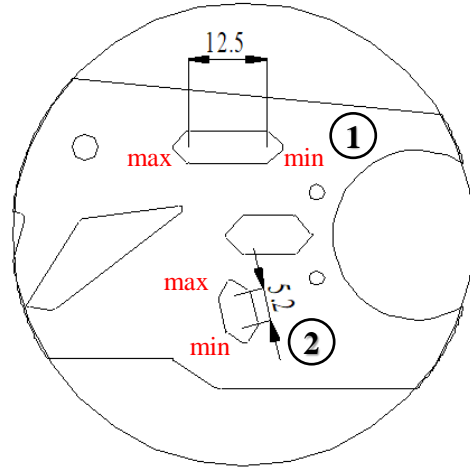

- ✓ Adjusting the Blue Bumpstop 1

Step 1: Remove spring assembly.

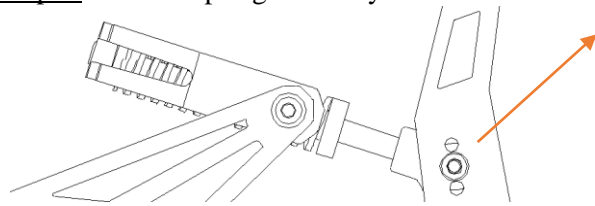

Remove bolts then
remove spring assembly

Step 2: Loosen the hex bolts **a** & **b** on the sides then choose the location of the blue bumpstop that works for you and tighten the hex bolts **b** you just loosened.

Step 3: Move the locating pin to fix the hex bolt **b** then tighten the hex bolt **a** (with VNM Throttle and VNM Clutch).

Step 4: Reinstall the spring assembly.

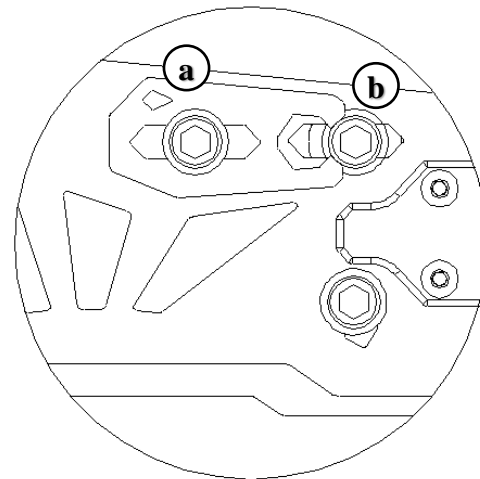

5. Exchange Spring & Elastomer (Brake)

Step 1: Remove the elastomer stack

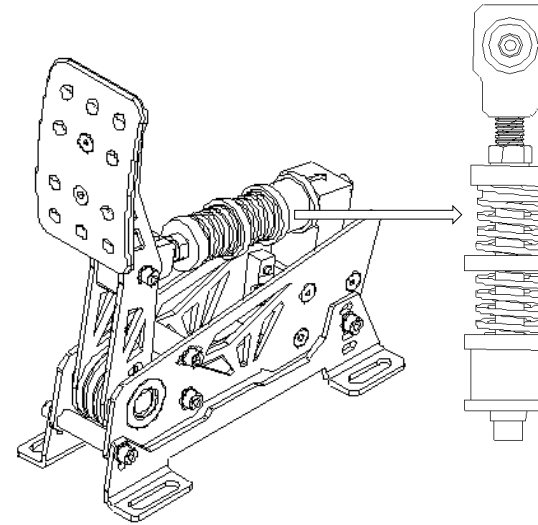

Step 2: Choose a suitable combination of springs and elastomers

3 combinations are recommended, but feel free to mix and match to find the perfect combo for you.

Option 1: Red, Blu, Yellow spring + 2 elastomers

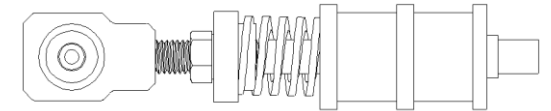

Option 2: Steel spring + 2 elastomers

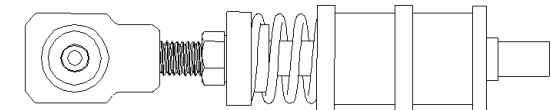

Option 3: 2 springs + 1 elastomer

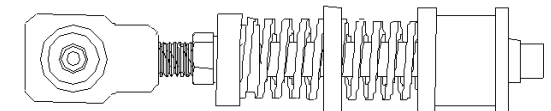

Step 3: Re-install the elastomer stack

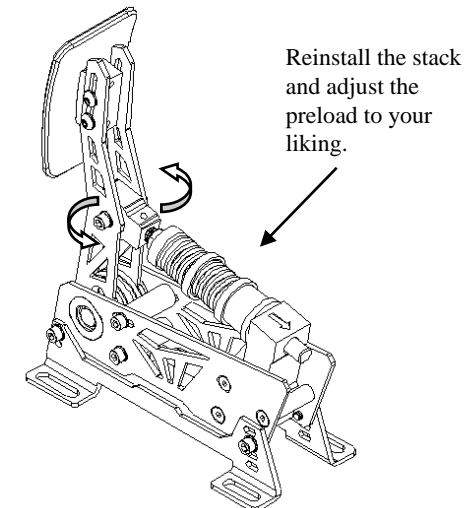

Reinstall the stack
and adjust the
preload to your
liking.

Throttle Mounting Dimension

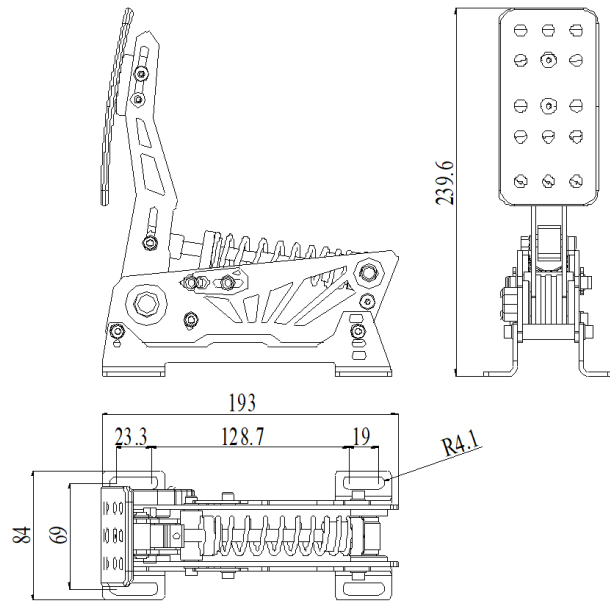

Brake Mounting Dimension

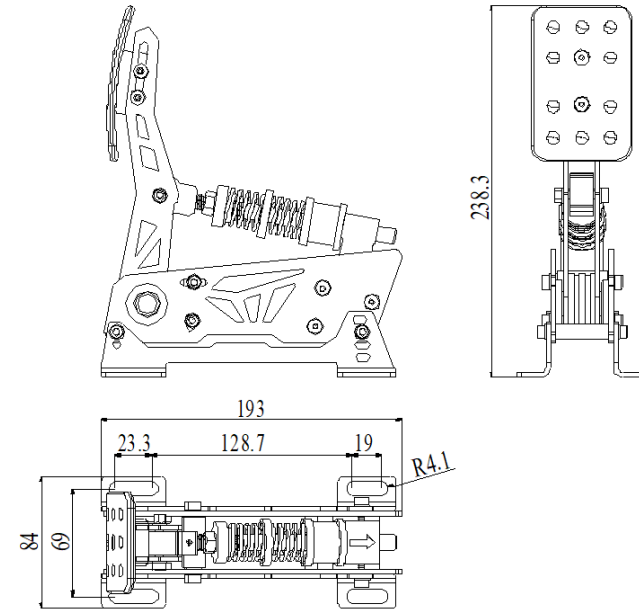

Controller Box Mounting Dimension

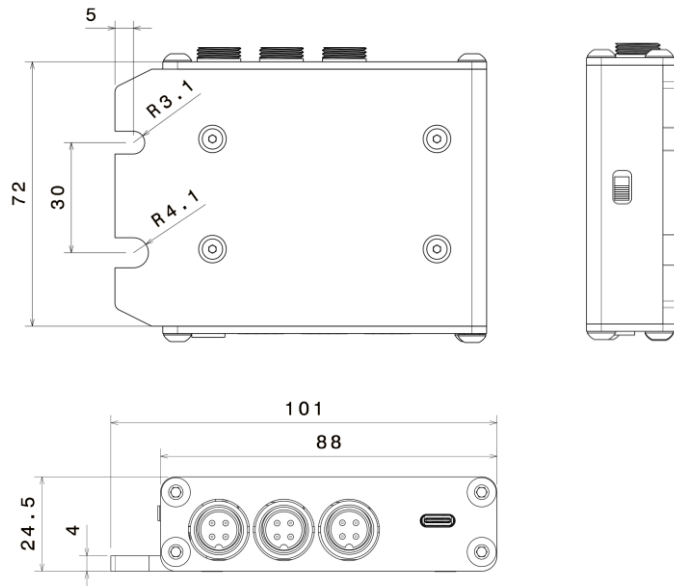

Clutch Mounting Dimension

