

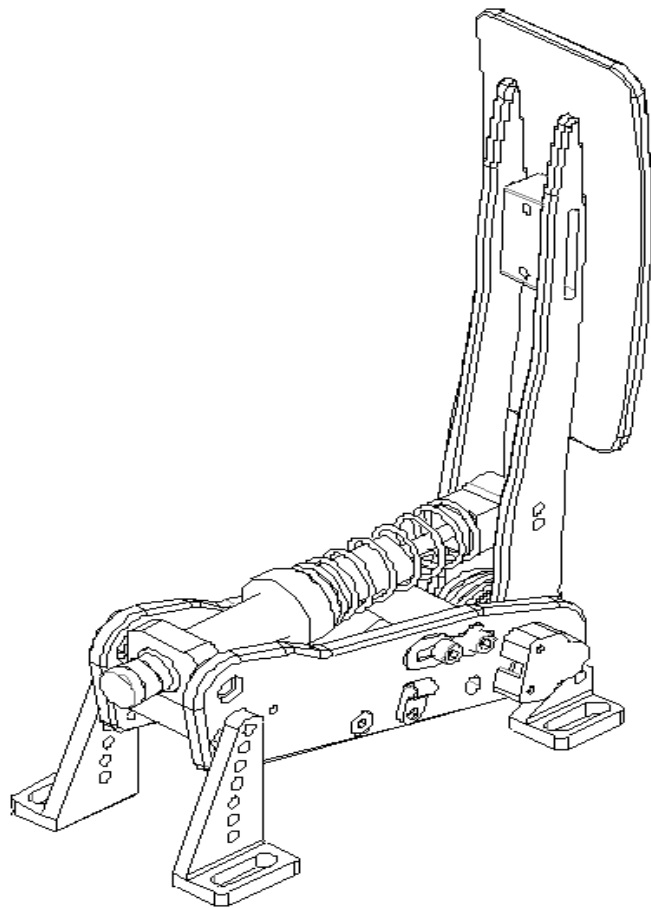

Installation guide

VNM Pedal Damper Throttle



Content

Damper AD2047

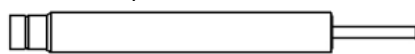

Damper Spring



3D printed spacer

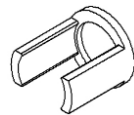

Pads Spring



M5x4 plastic-headed grub screw



Adjust Spring



M5x4 flat-headed grub screw



Step 1: Remove the spring

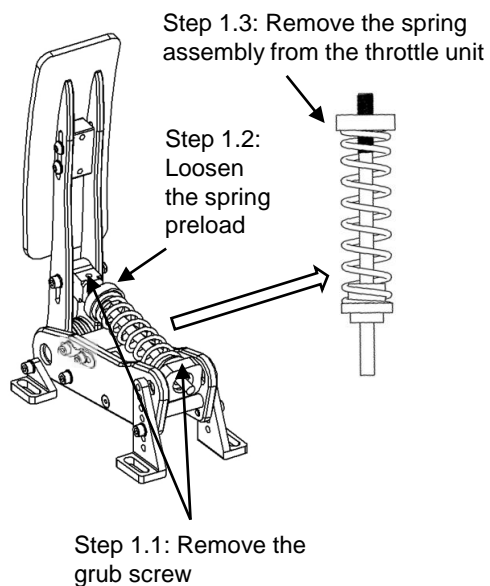

Step 2: Replace the spring assembly with the damper cylinder

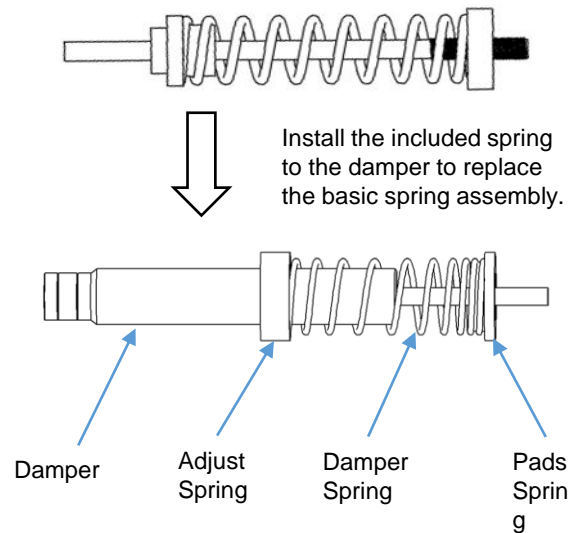

Step 3: Install the damper

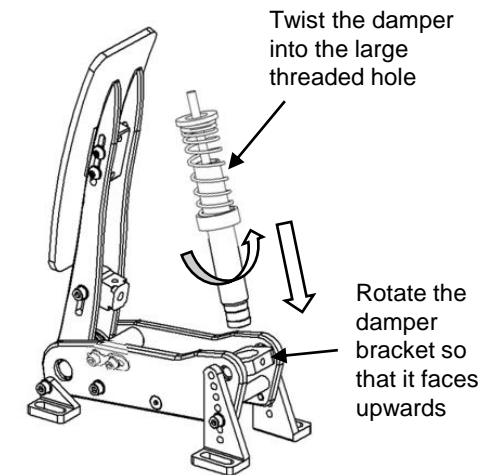

Step 4: Fix the damper rod's end to the pedal arm

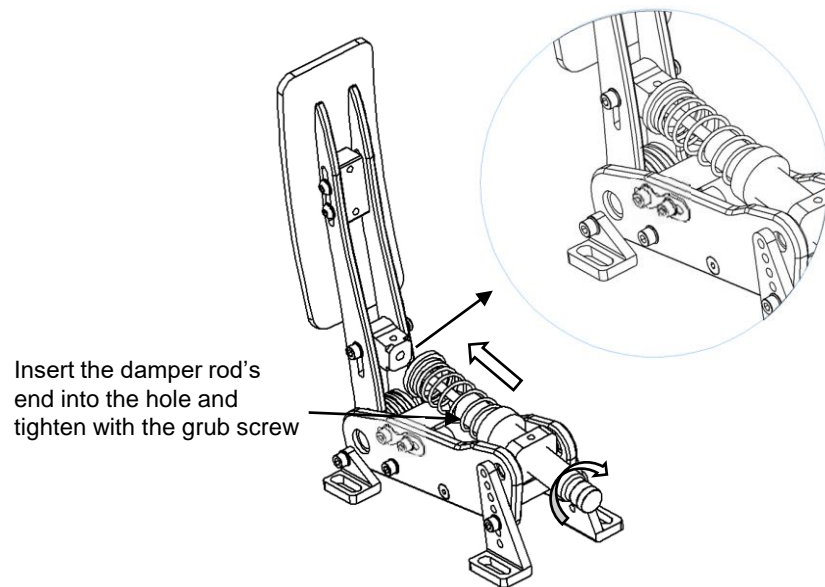

Step 5: Adjust the damper

