

Installation guide VNM Pedal Damper Clutch

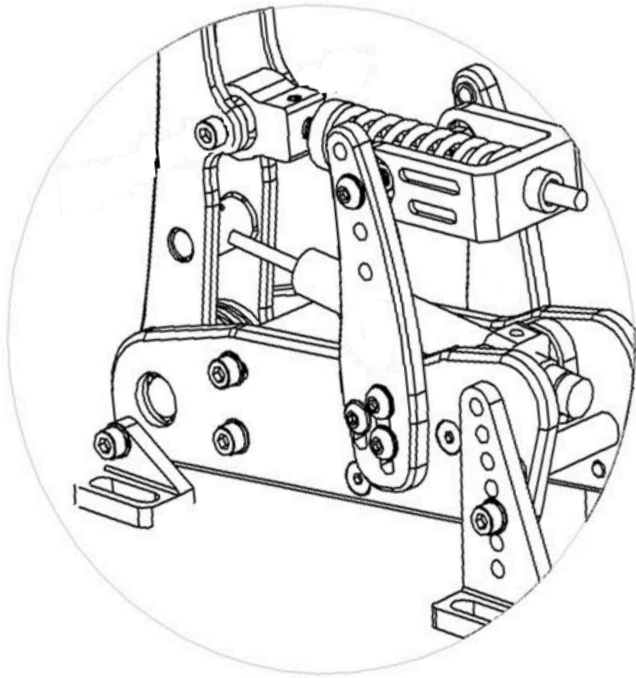

Assemble the damper mount

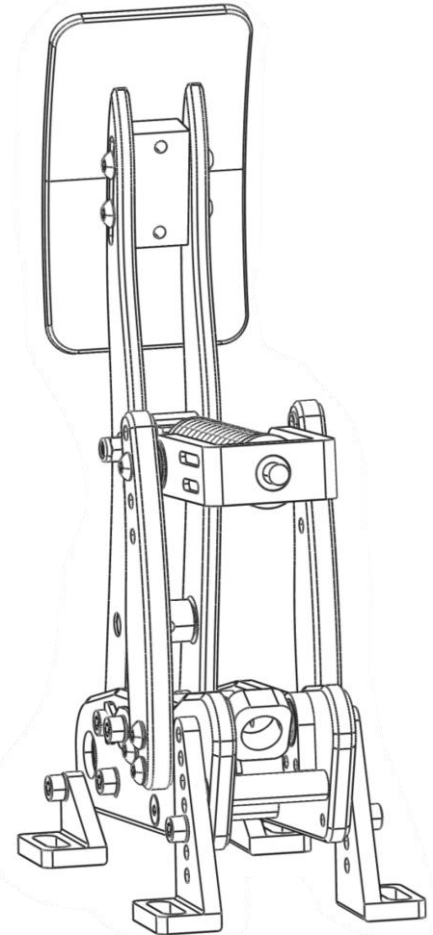
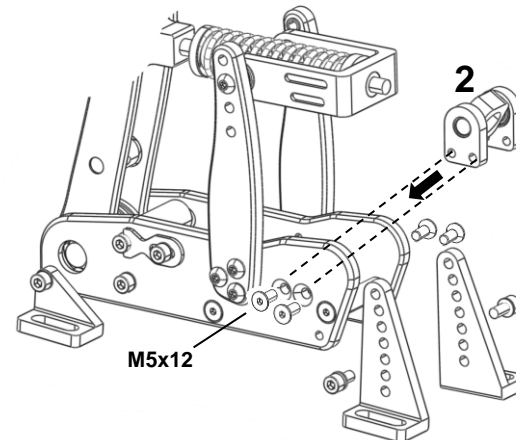
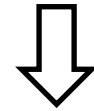
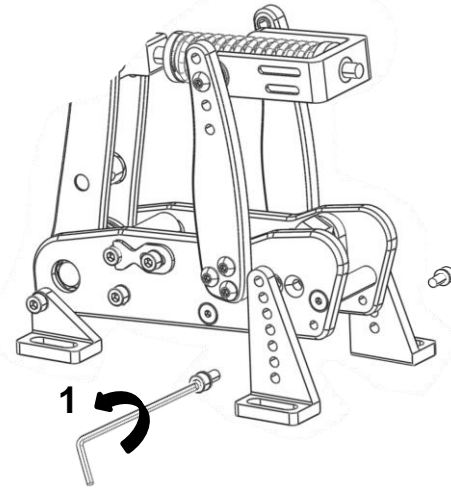

Content

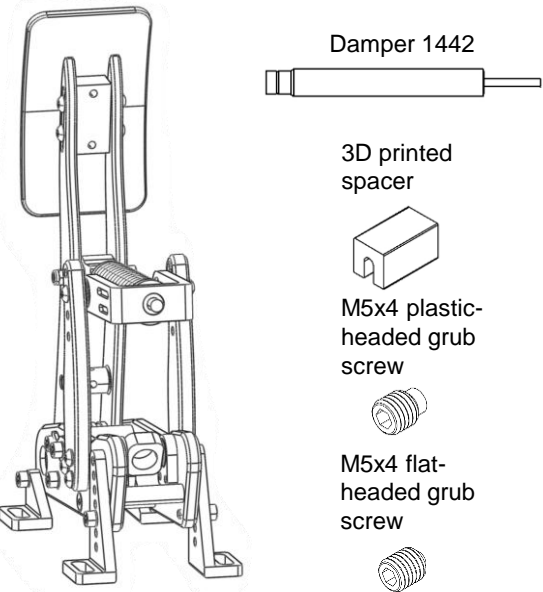

Step 1: Remove the spring

Remove the nut, bolt and washers to uninstall the spring

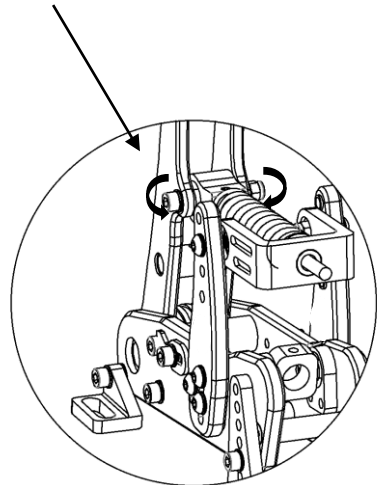

Step 2: Remove the bumpstop

Remove the 2 hex bolts on the sides, push the pedal arm backwards and slide the blue bumpstop downwards

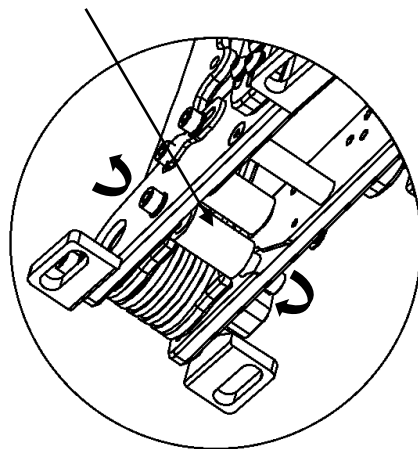

Step 3: Install the damper

Twist the damper into the large threaded hole

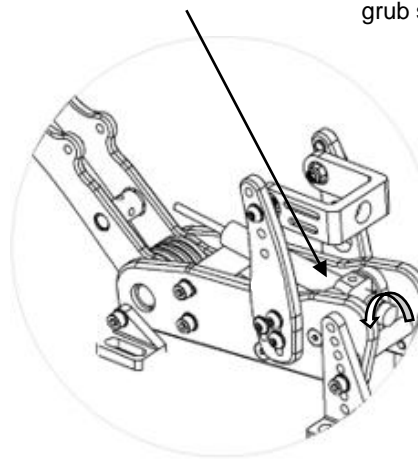

Insert the smaller end of the piston into the hole and tighten with the flat-headed grub screw

M5x6 flat headed grub screw

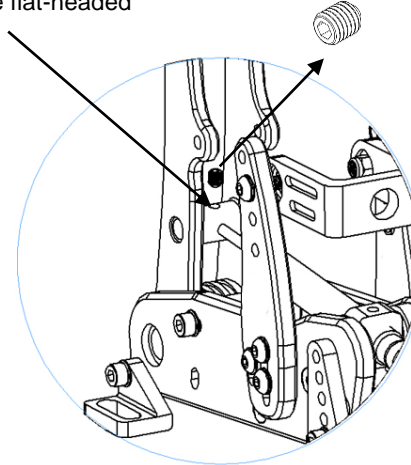

Step 4: Adjust the damper

Step 4.1: Insert the 3D printed spacer.

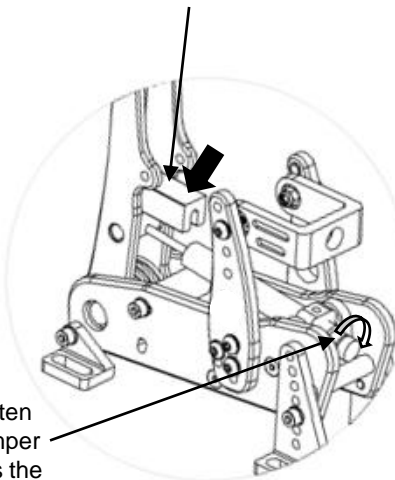

Step 4.2: Tighten the whole damper until it touches the spacer

Step 5: Tighten the damper and remove the spacer

Fix the damper in place by screwing in the plastic-headed grub screw

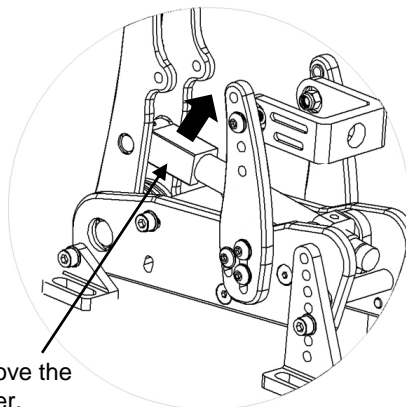

Remove the spacer.

Step 6: Re-install the bumpstop.

Push the pedal arm backwards, slide the blue bumpstop back in place and tighten the bolts

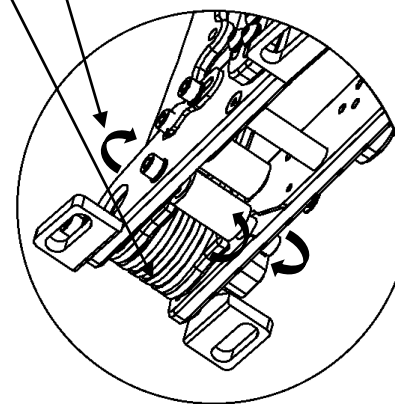

Step 7: Re-install the springs

