

Installation guide VNM Pedal Damper Brake

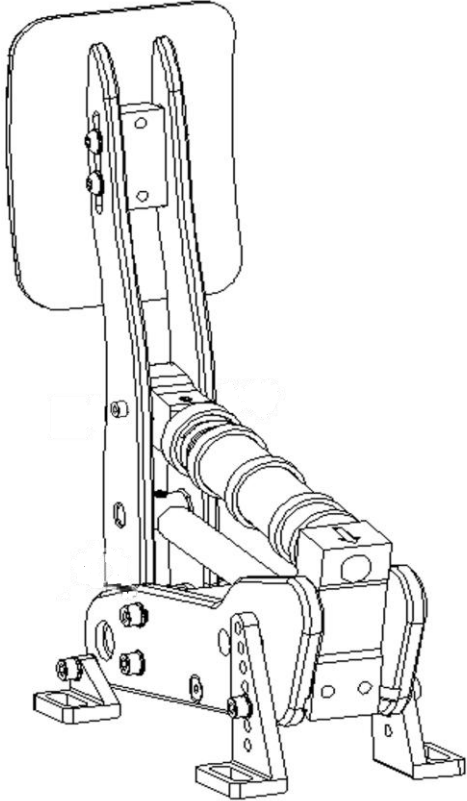

Assemble the damper mount

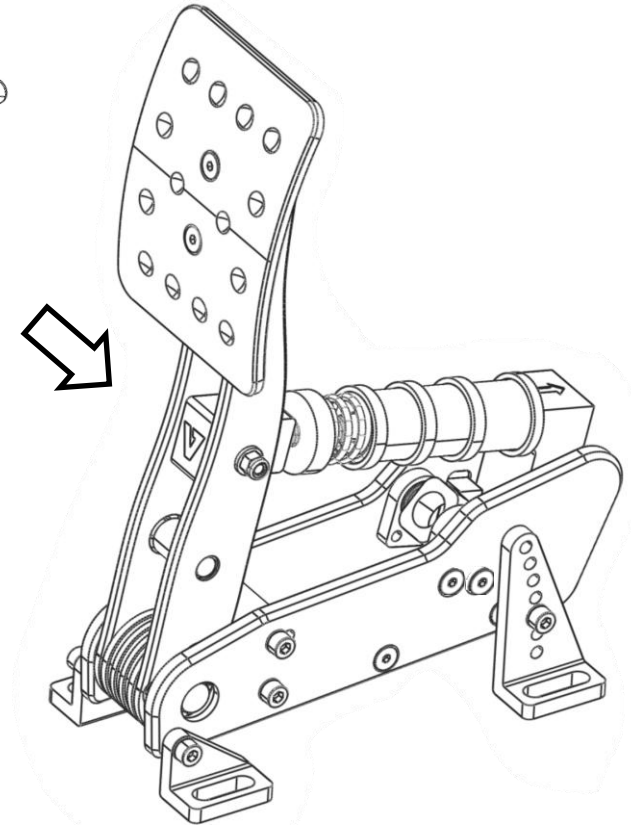
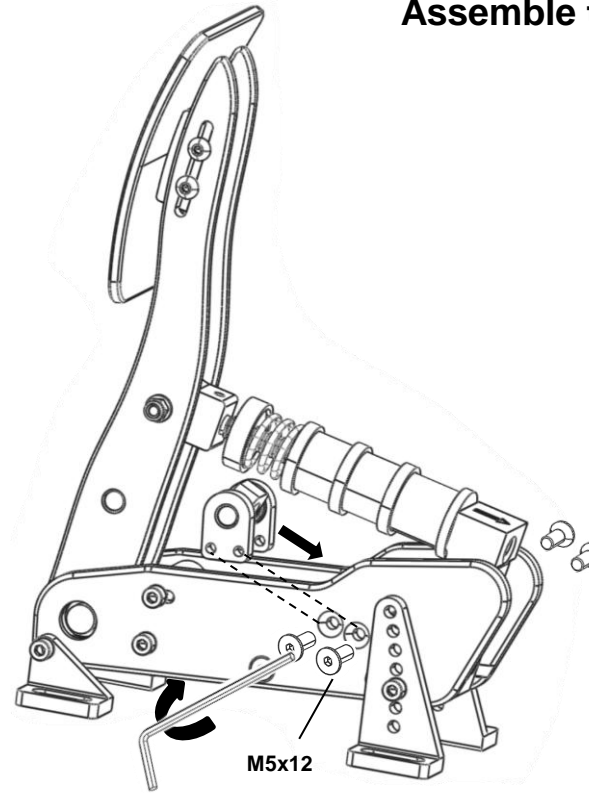

Content

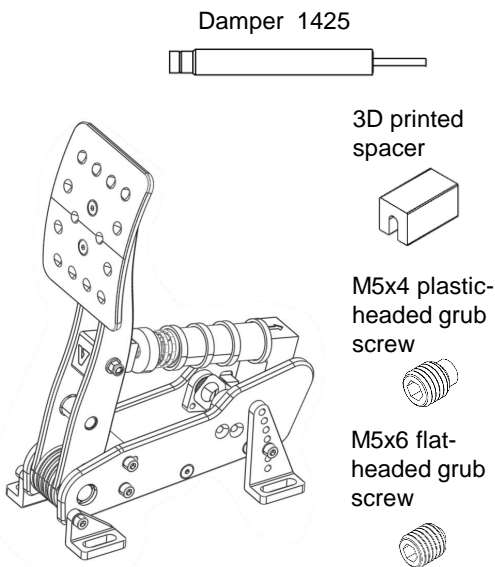

Step 1: Remove the elastomer stack

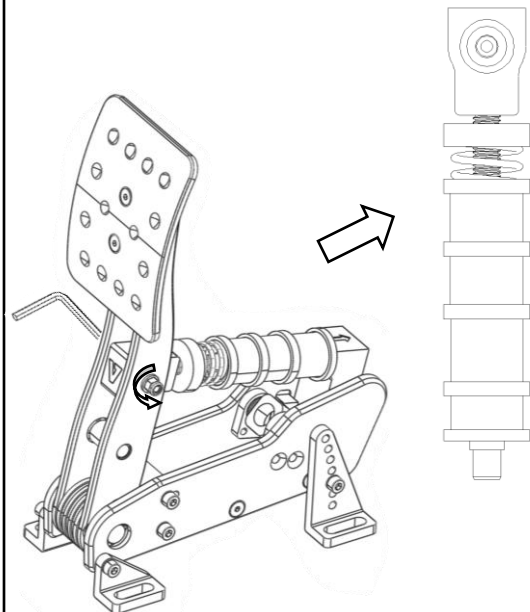

Step 2: Remove the bumpstop

Remove the 2 hex bolts on the sides, push the pedal arm backwards and slide the blue bumpstop downwards

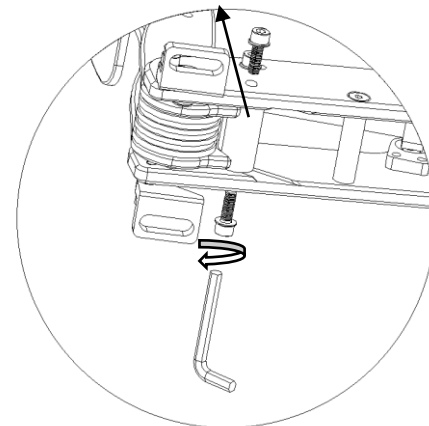

Step 3: Install the damper

Insert the piston shaft into the hole and tighten with the grub screw

Twist the damper into the large threaded hole

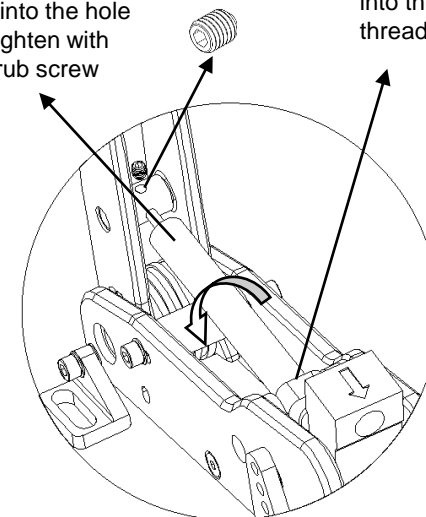

Step 4: Adjust the damper

Step 5.2: Tighten the whole damper until it touches the spacer

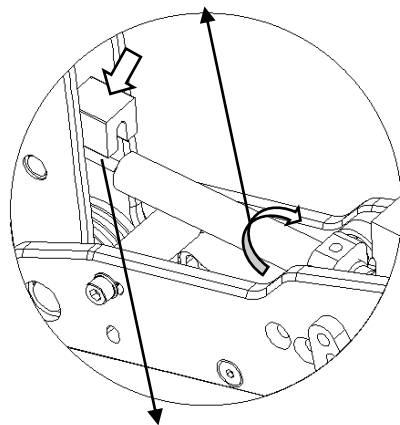

Step 5.1: Insert the 3D printed spacer.

Step 5: Tighten the damper and remove the spacer

Step 6.1: Fix the damper in place by screwing in the plastic-headed grub screw

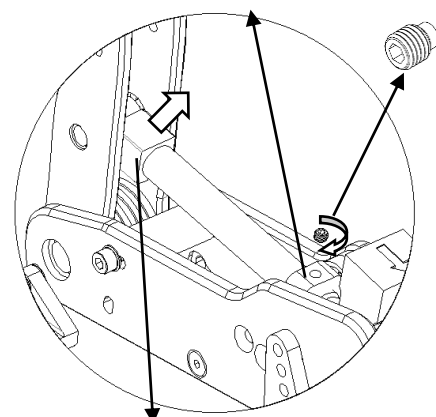

Step 6.2: Remove the spacer.

Step 6: Re-install the bumpstop.

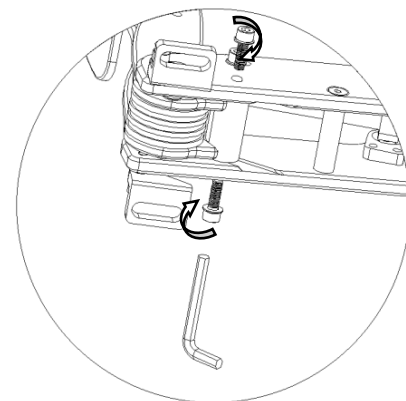

Step 7: Re-install the elastomer stack

Reinstall the stack and adjust the preload to your liking.

