

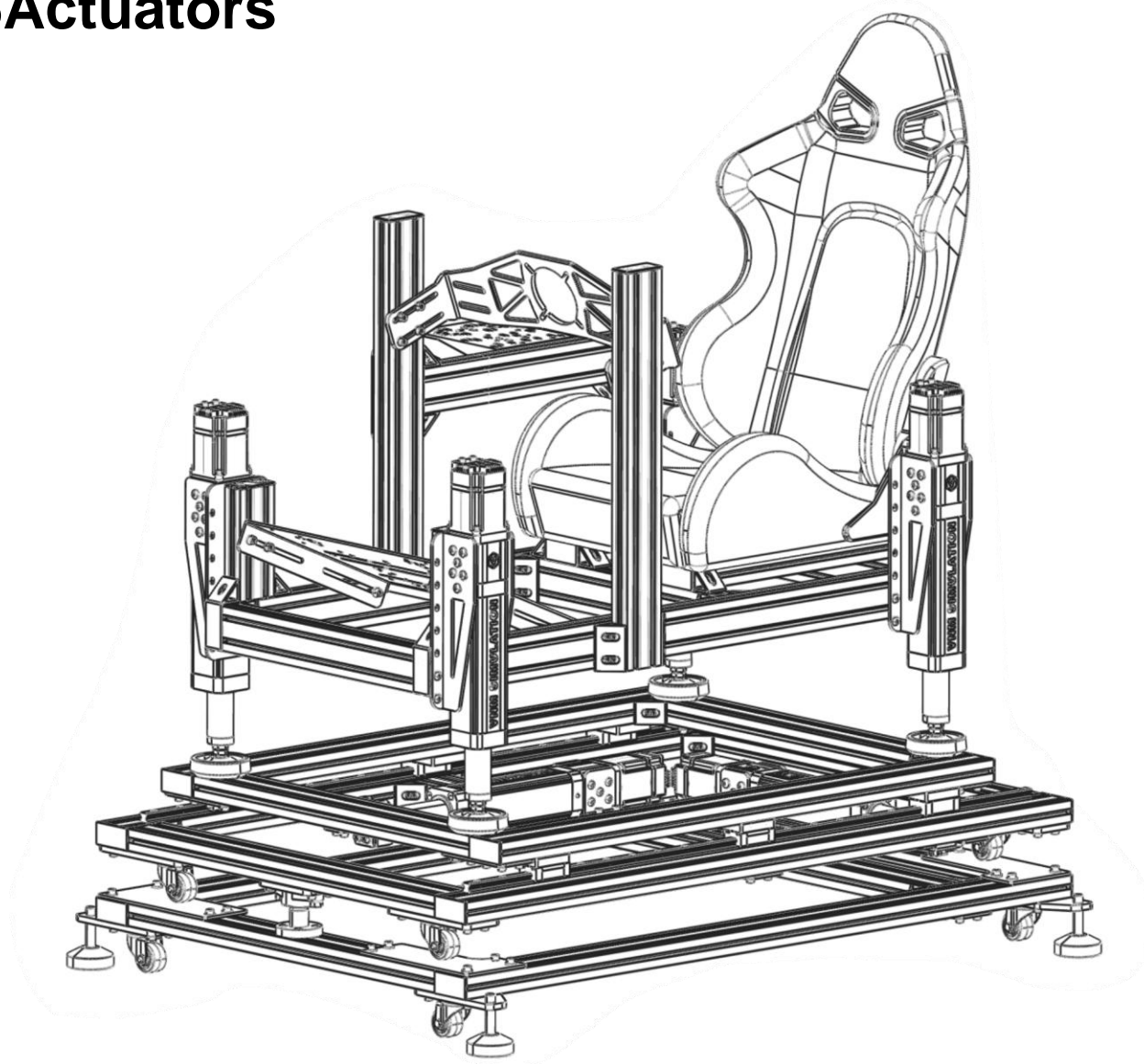

# Installation guide

## VNM Rig 5Dof 6Actuators



Monitor

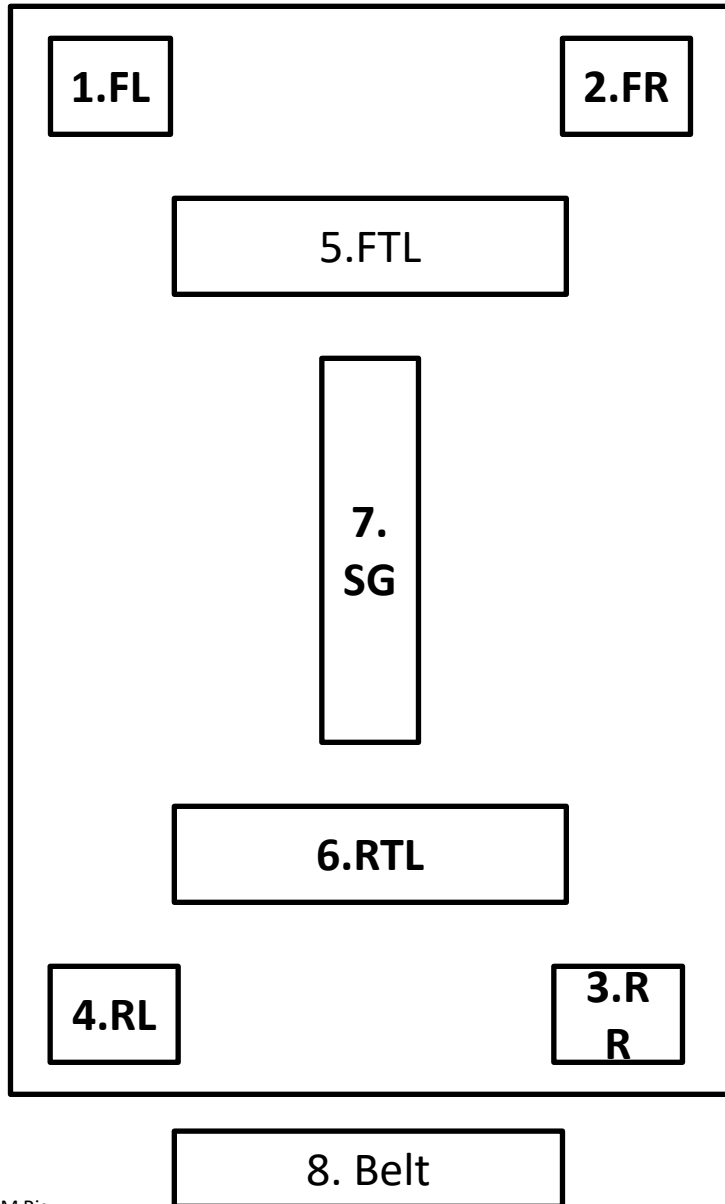

*Actuator installation order*



**Warning:** Before installing or configuring the motion system on your rig, ensure that the surrounding area is completely clear. This helps prevent collisions if the rig moves unexpectedly. Keep the motion rig away from nearby objects such as computer monitors, TVs, mobile phones, etc.

# Installation guide

## VNM Rig 3Dof 4Actuators

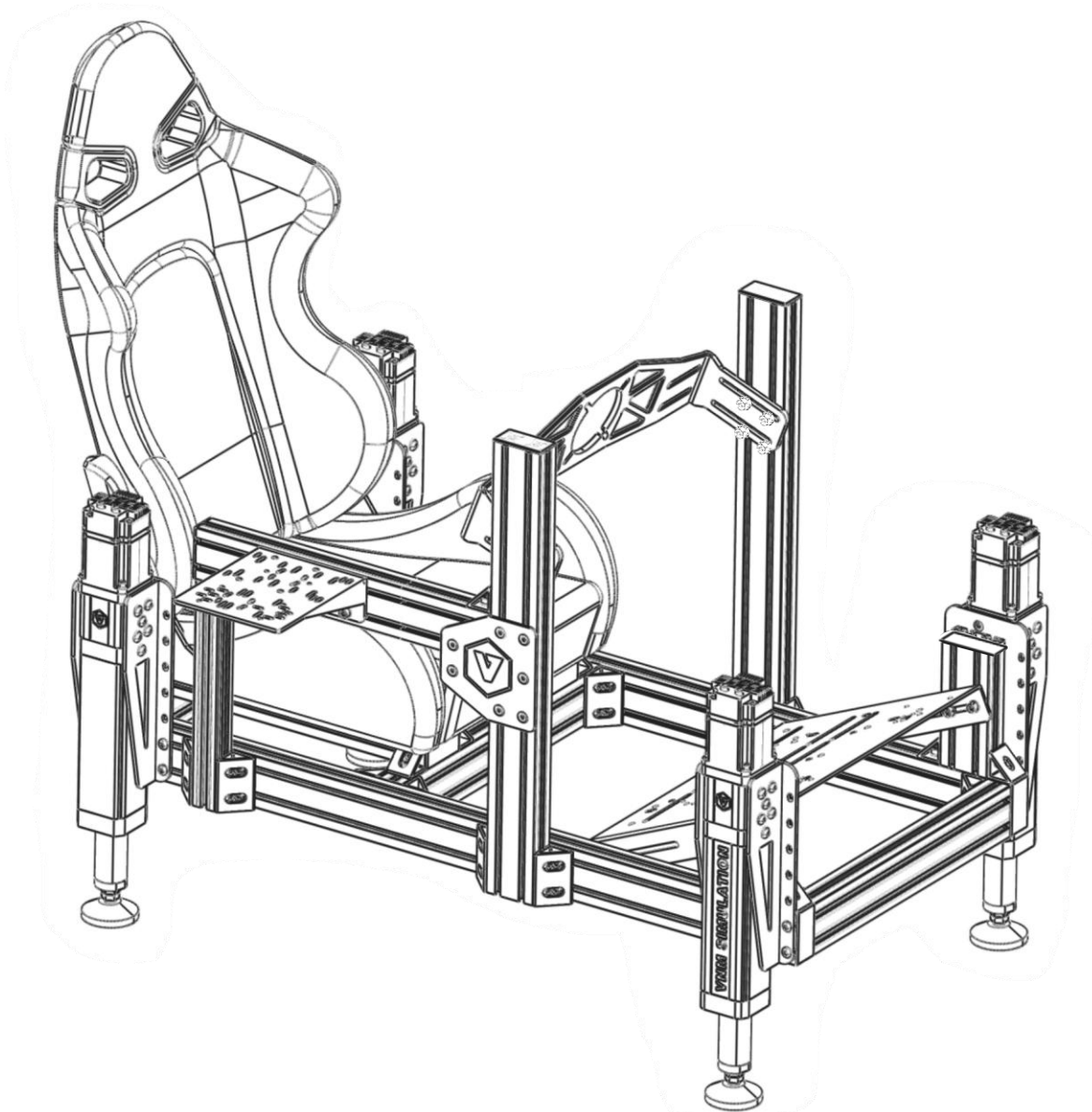

① 40x80x1200  
x2

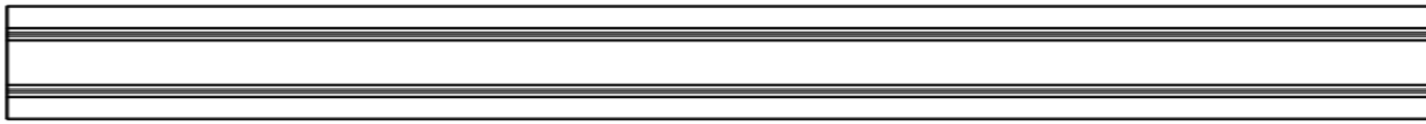

② 40x80x720  
x2

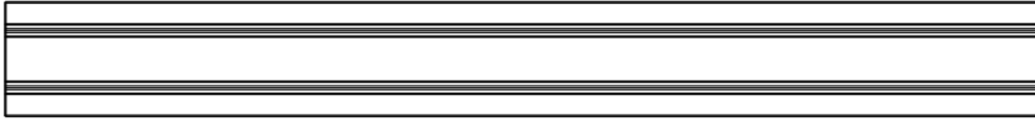

③ 40x80x500  
x6

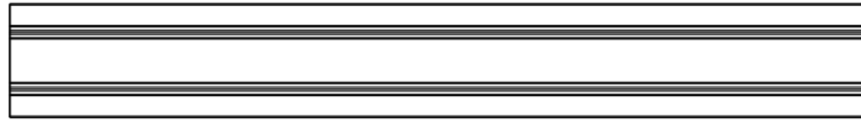

④ 40x40x350  
x1

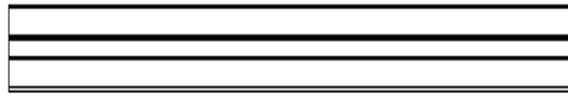

⑤ 40x80x200  
x2

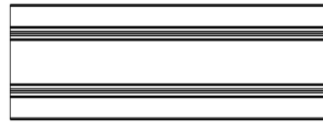

⑥ VNM Actuator  
(with U bracket)  
x4

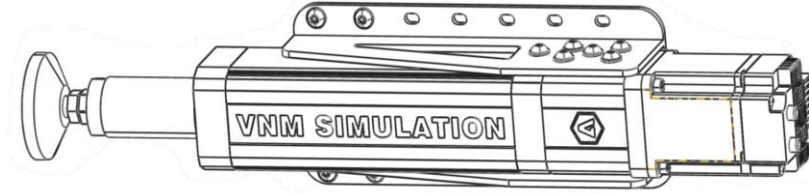

⑦ VNM Plate  
x1

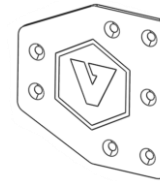

⑧ Handbrake  
Shifter Bracket  
x1

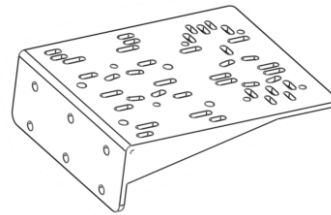

⑨ Pedal base plate V3  
x1

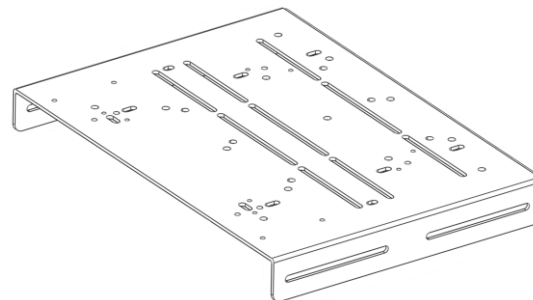

⑩ Wheel base mount V1  
x1

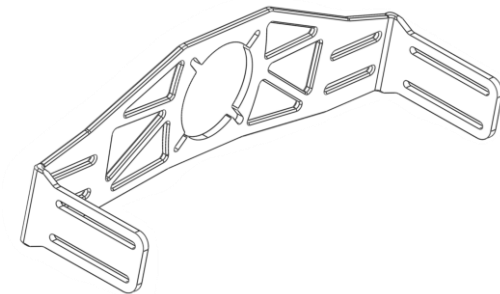

11

### Driver's Seat

(May not include)

x1

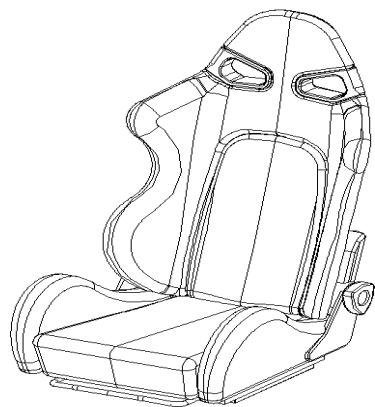

Flat, Spring M8

x86



M8x20

x8



M8x16

x120



M8 Slider

x135

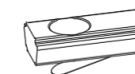

M16 Nuts, Spring M16

x4



M8x16

x7



M8x16

x48



12

### Actuator Feet

x4

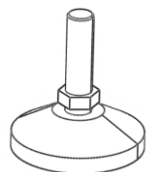

4080 Conner Alu

x14

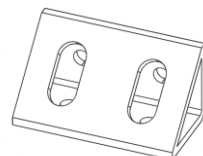

4040 Conner Alu

x15



Alu Cover

x13

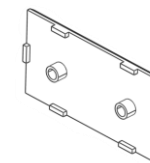

# Method 1

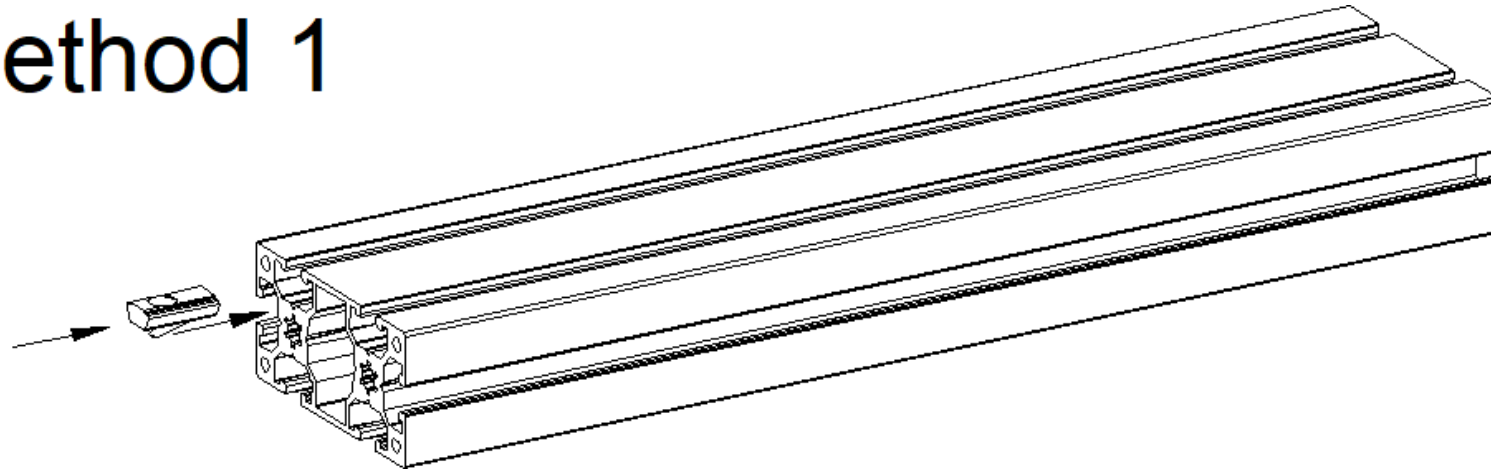

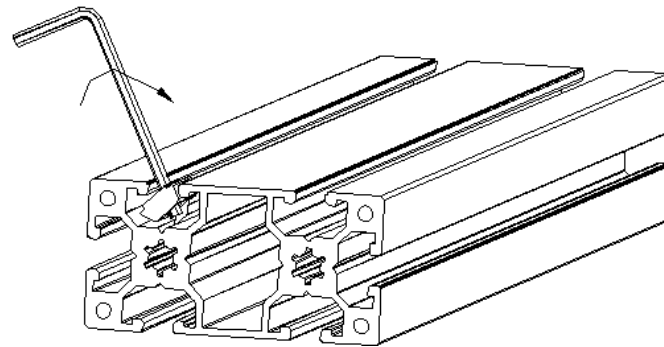

# Method 2

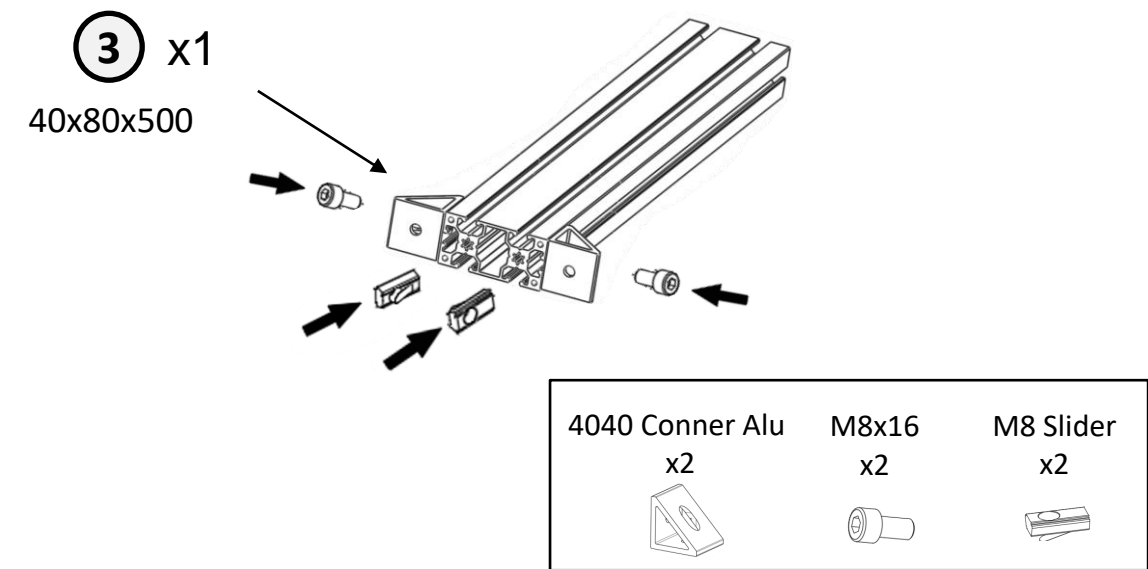
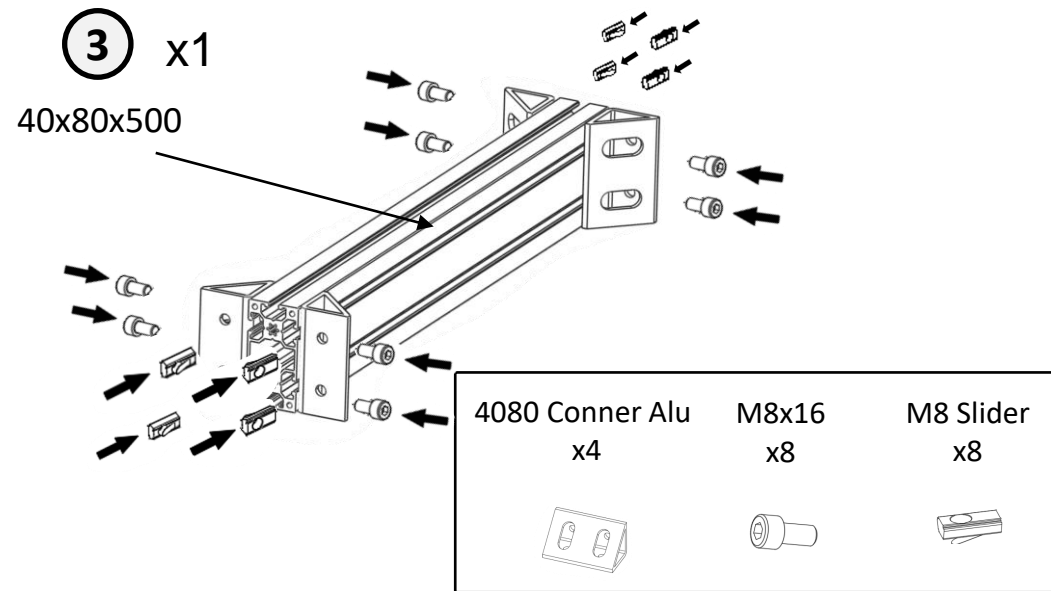
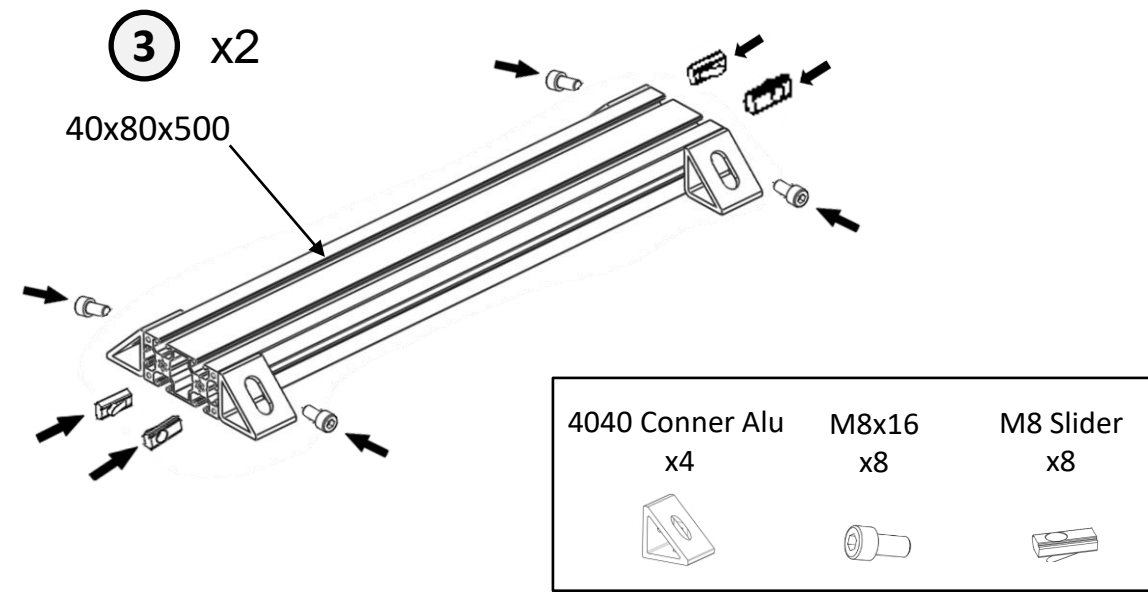
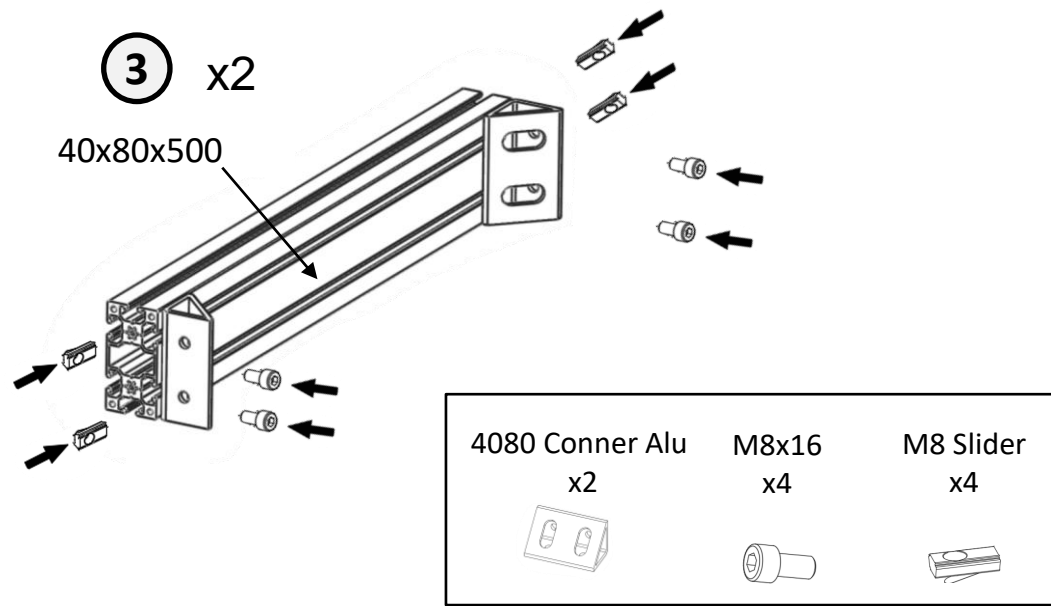

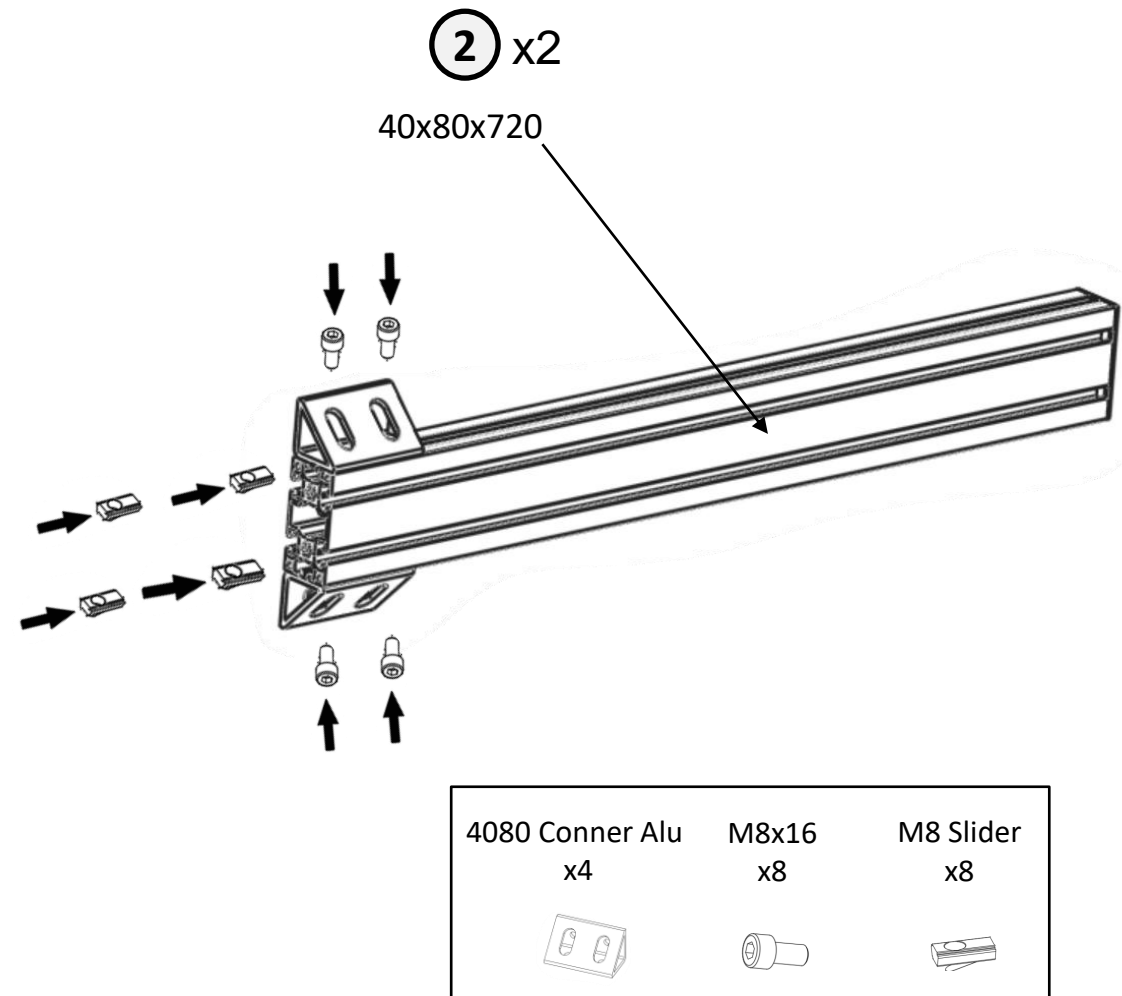
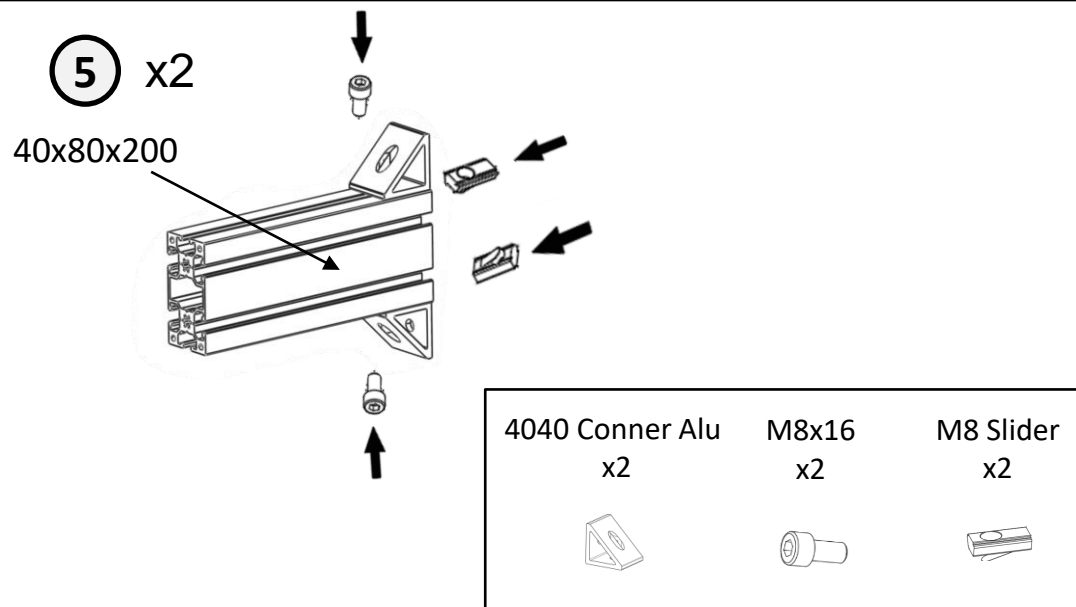
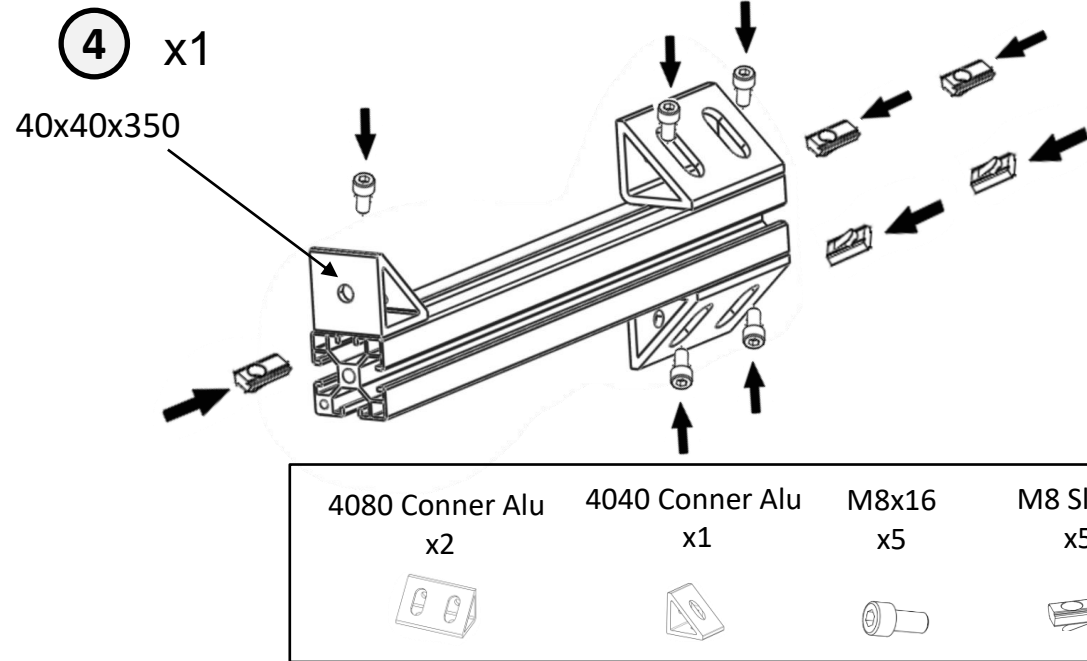





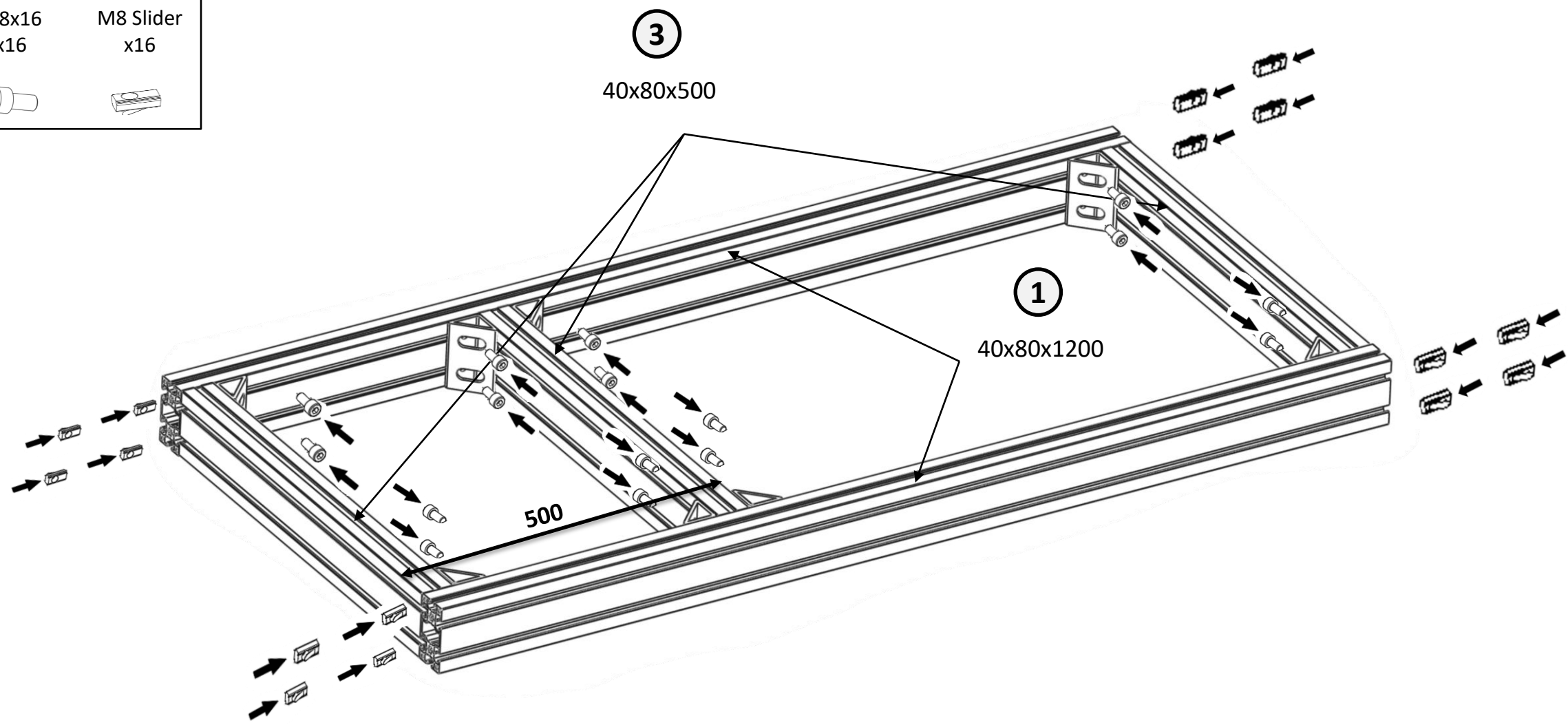

M8x16 x16	M8 Slider x16
	



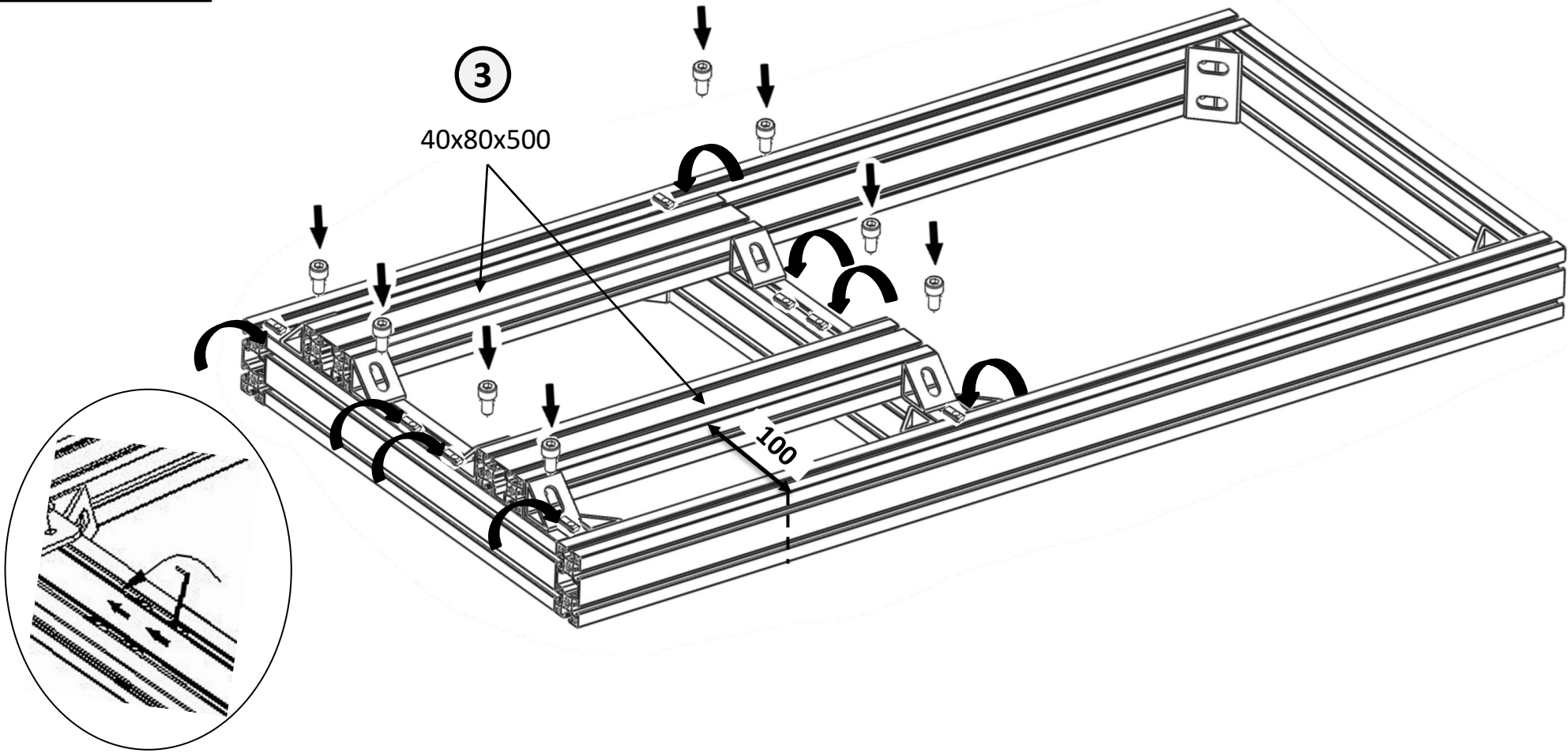

M8x16 x8	M8 Slider x8
	



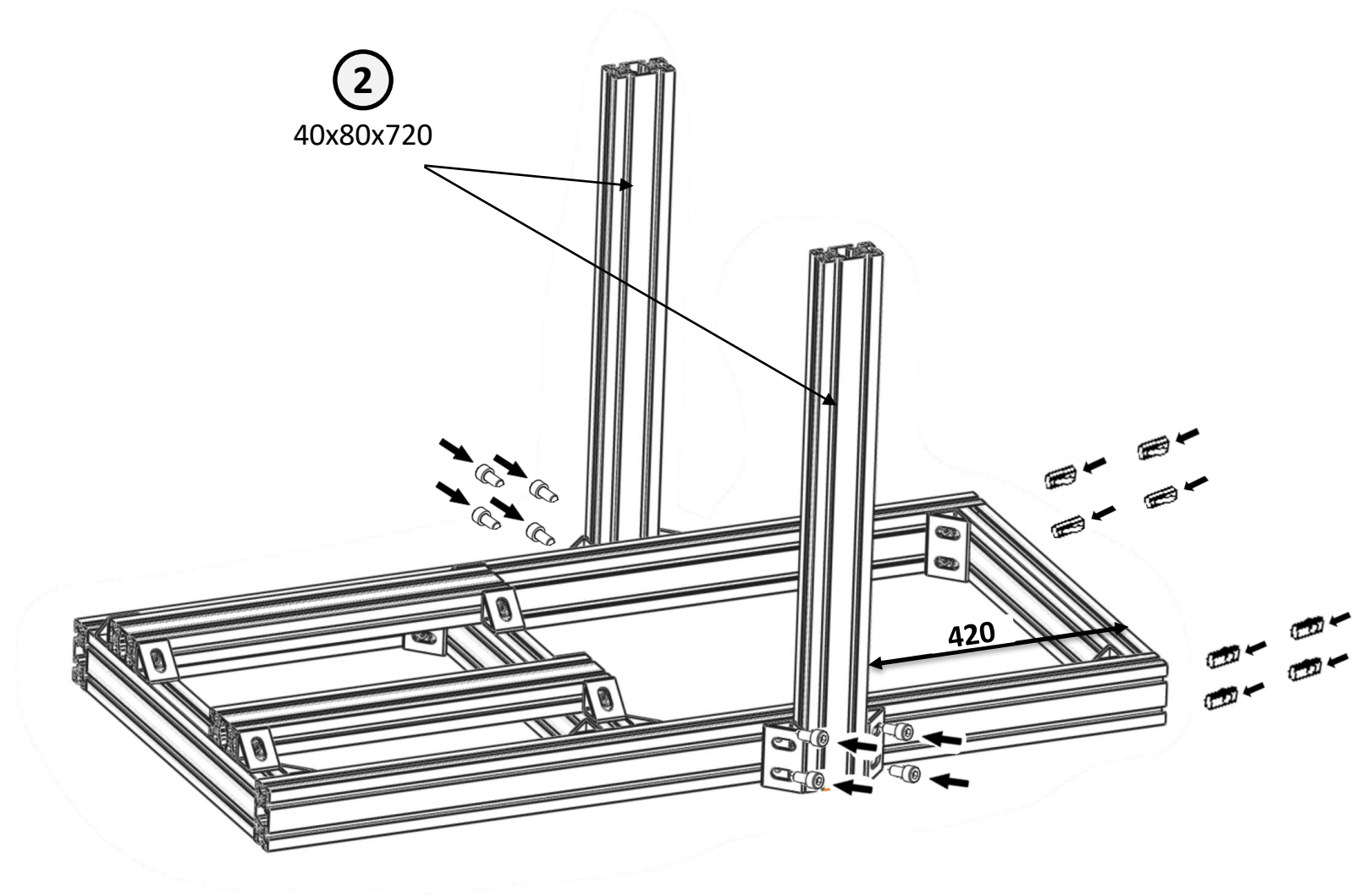

M8x16 x8	M8 Slider x8
	



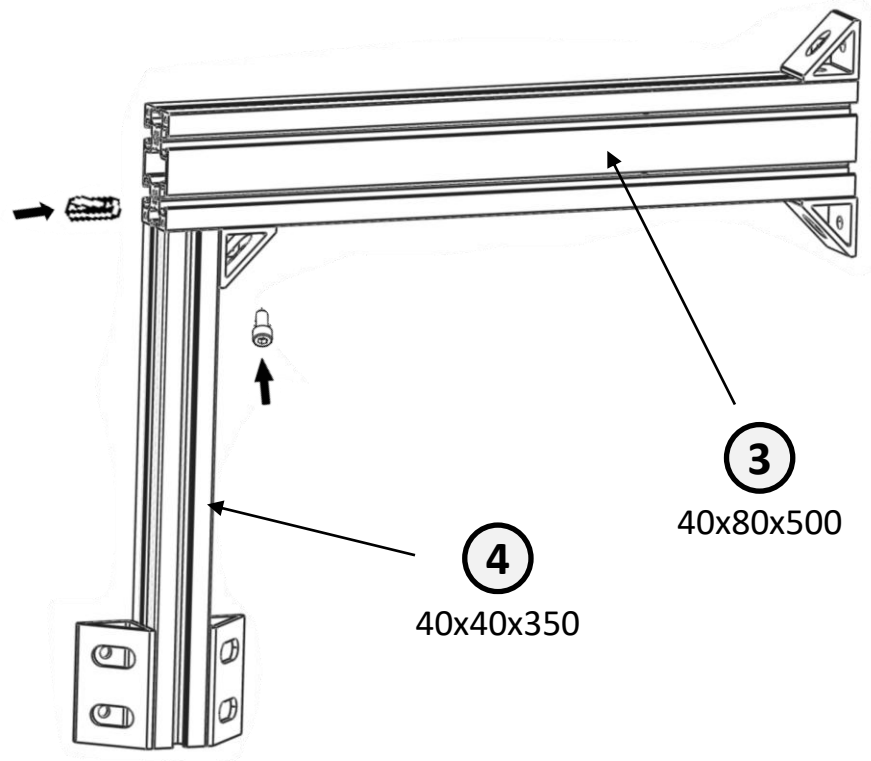

M8x16 x1	M8 Slider x1
	



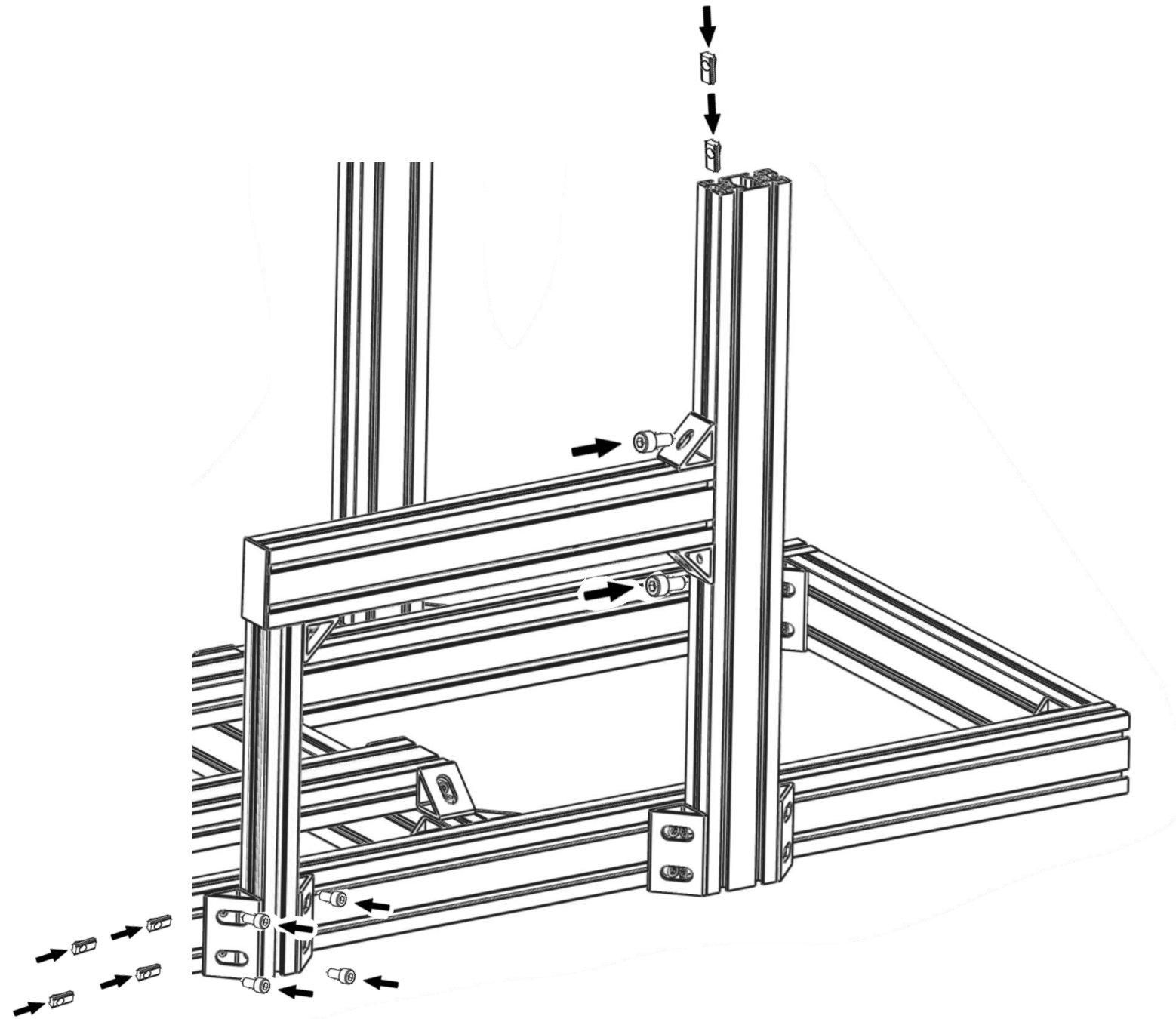

M8x16 x6	M8 Slider x6
	

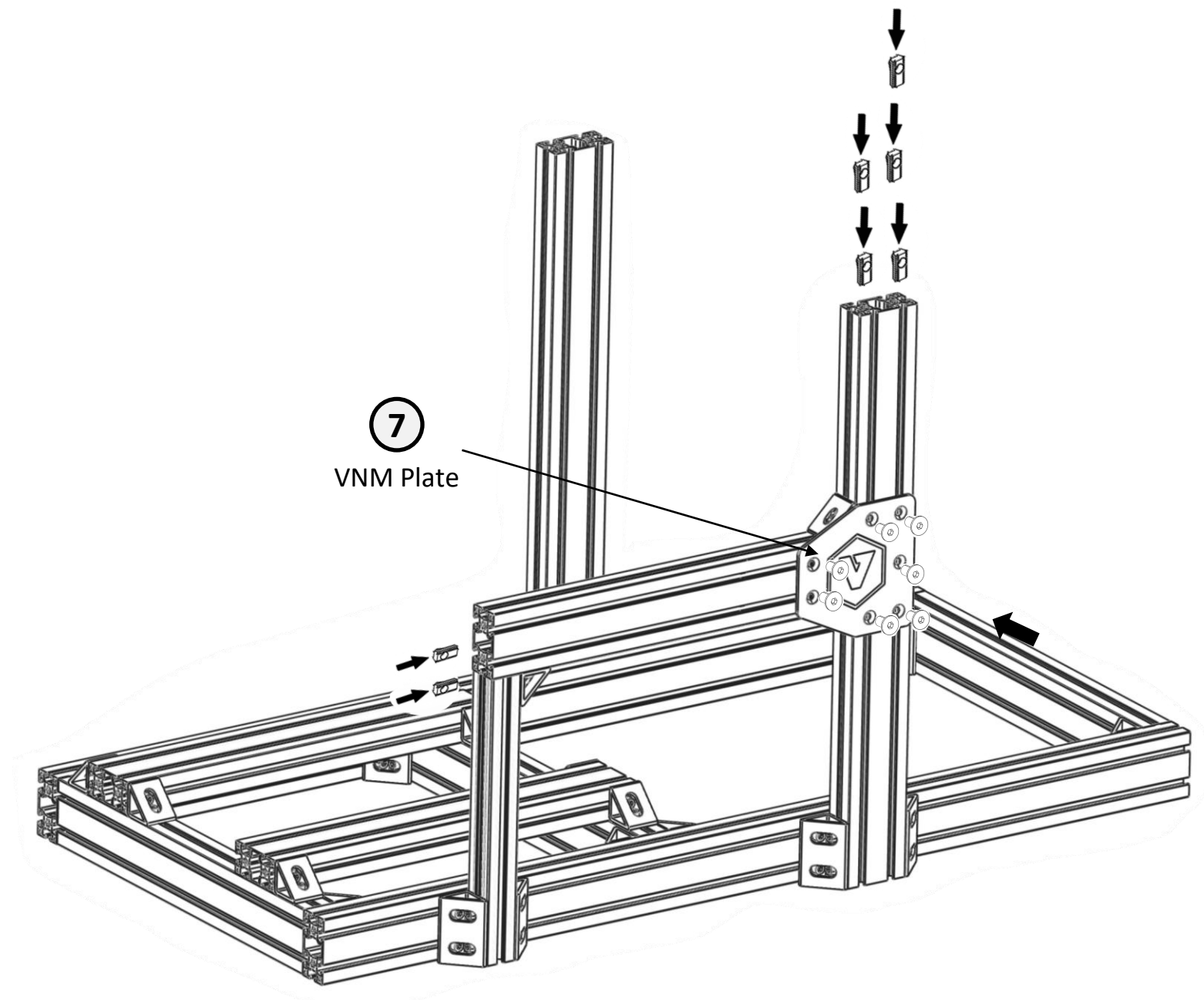

M8x16 x7	M8 Slider x7
	







M8x16 x6	M8 Slider x6	Flat, Spring M8 x6
		

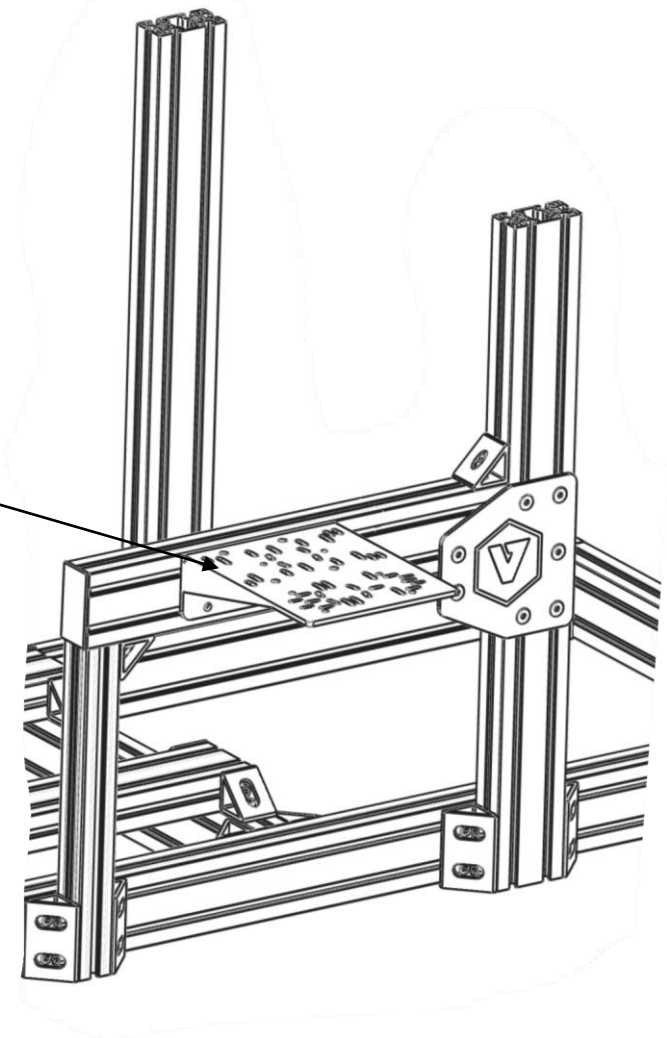
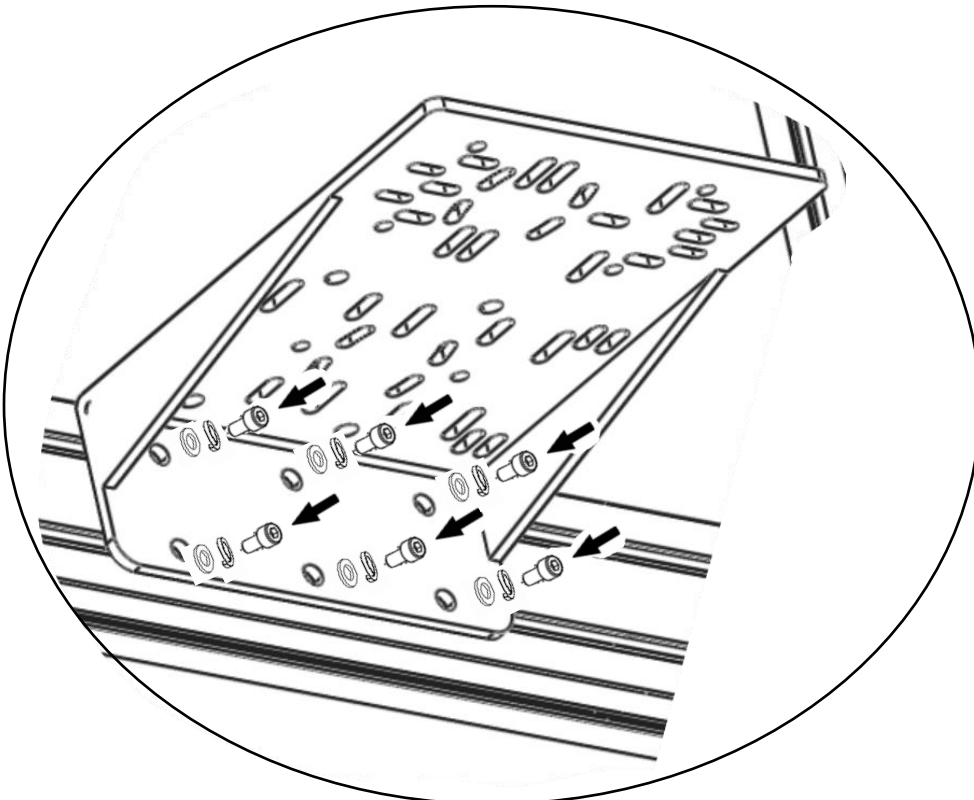

8

Handbrake Shifter  
Bracket



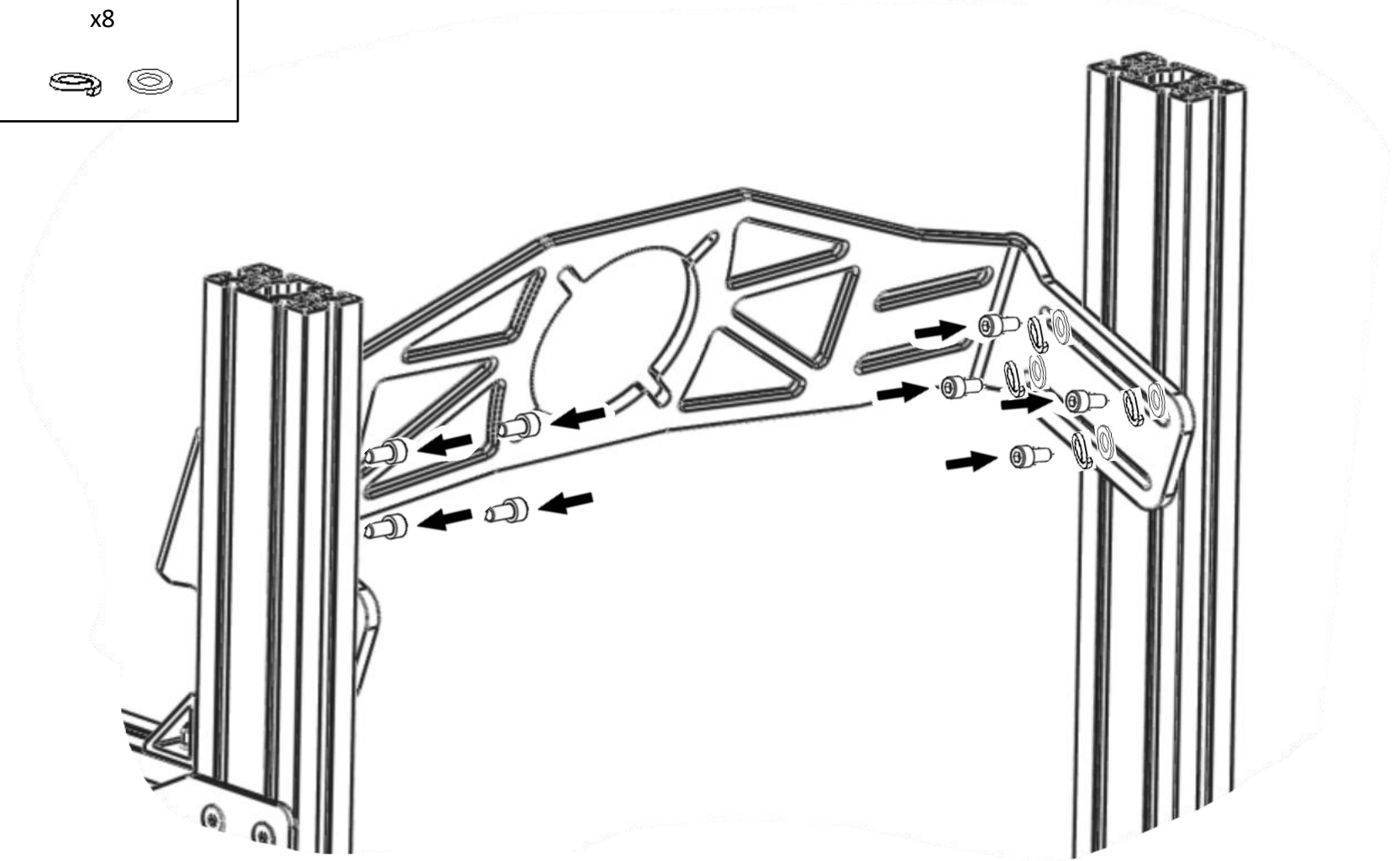

M8x20 x8	M8 Slider x8	Flat, Spring M8 x8
		 

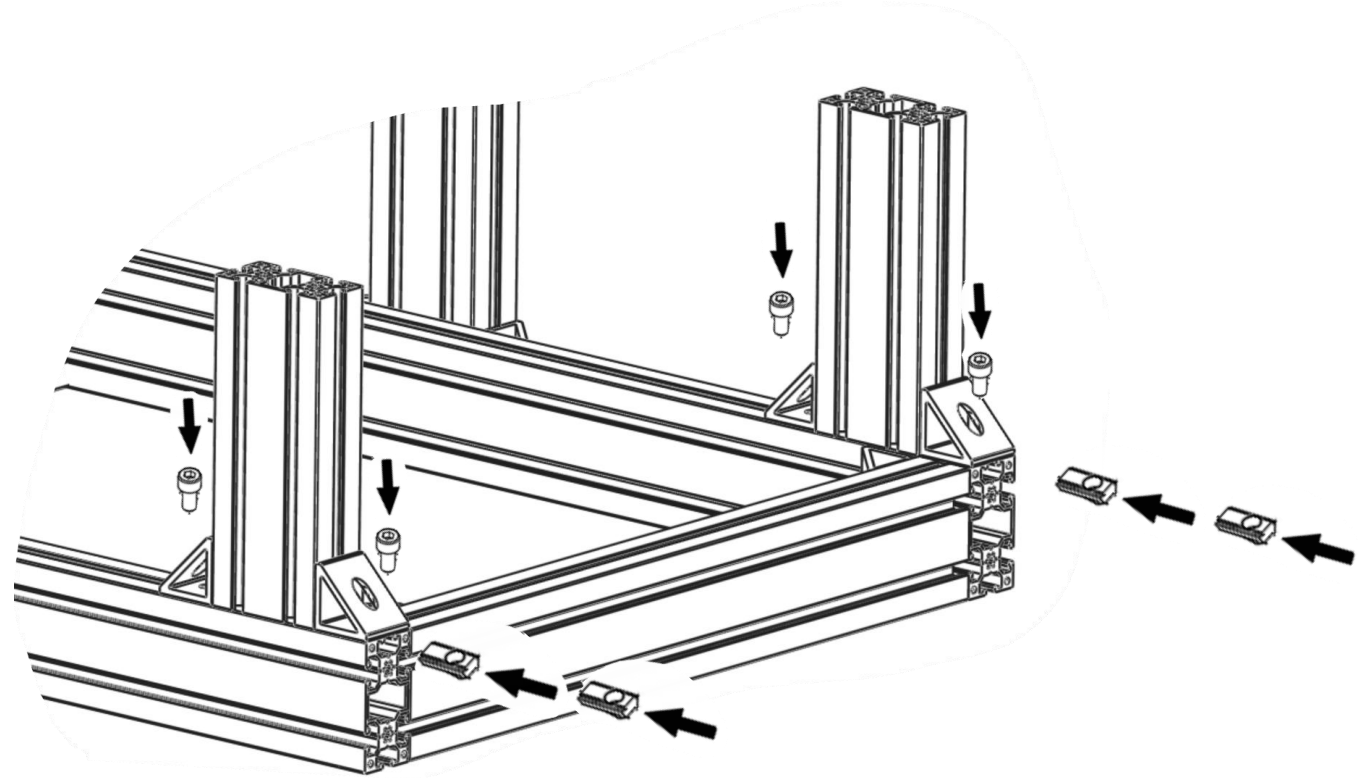

M8x16 x4	M8 Slider x4
	

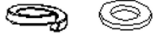

M8x16 x6	M8 Slider x6	Flat, Spring M8 x6
		

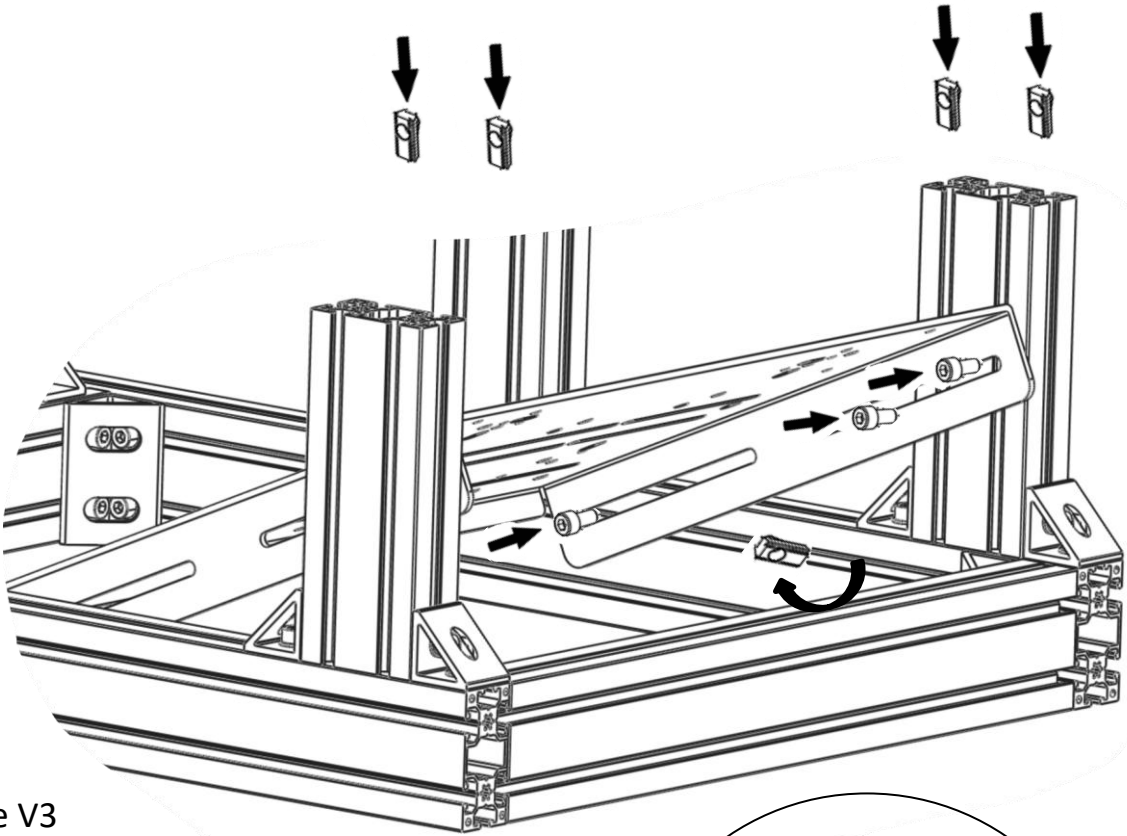

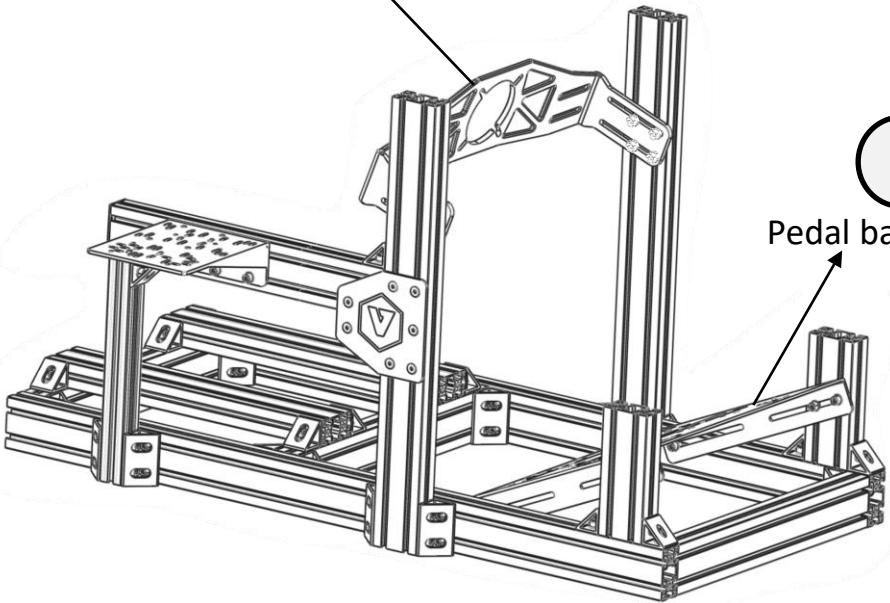

**10**  
Wheel Base Mount  
V1



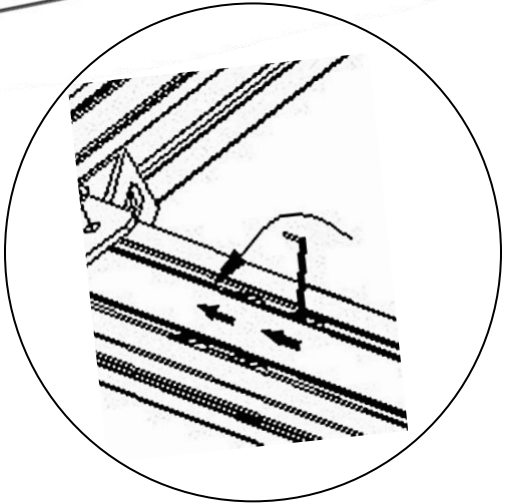

**9**  
Pedal base plate V3

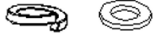

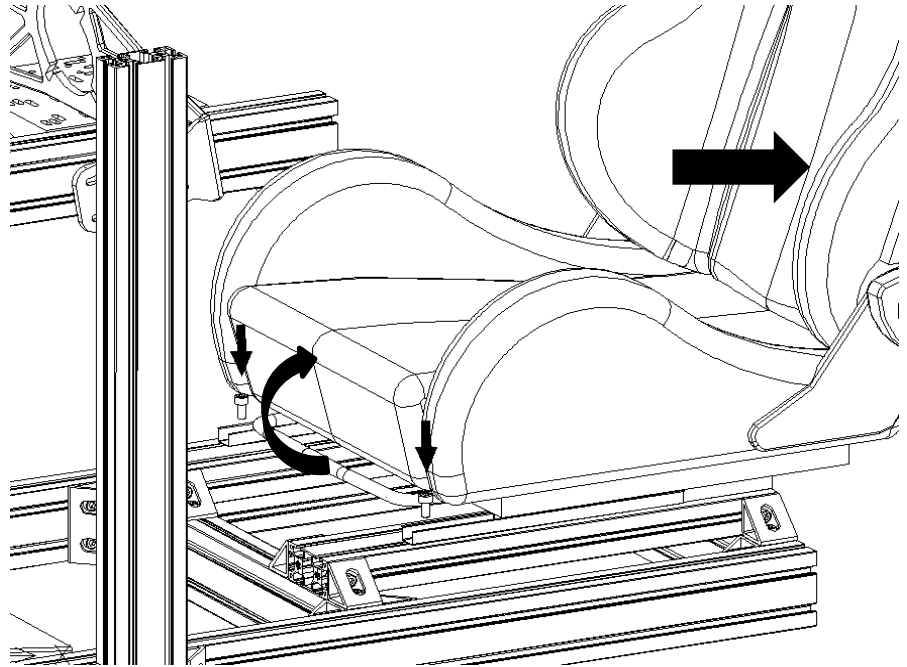
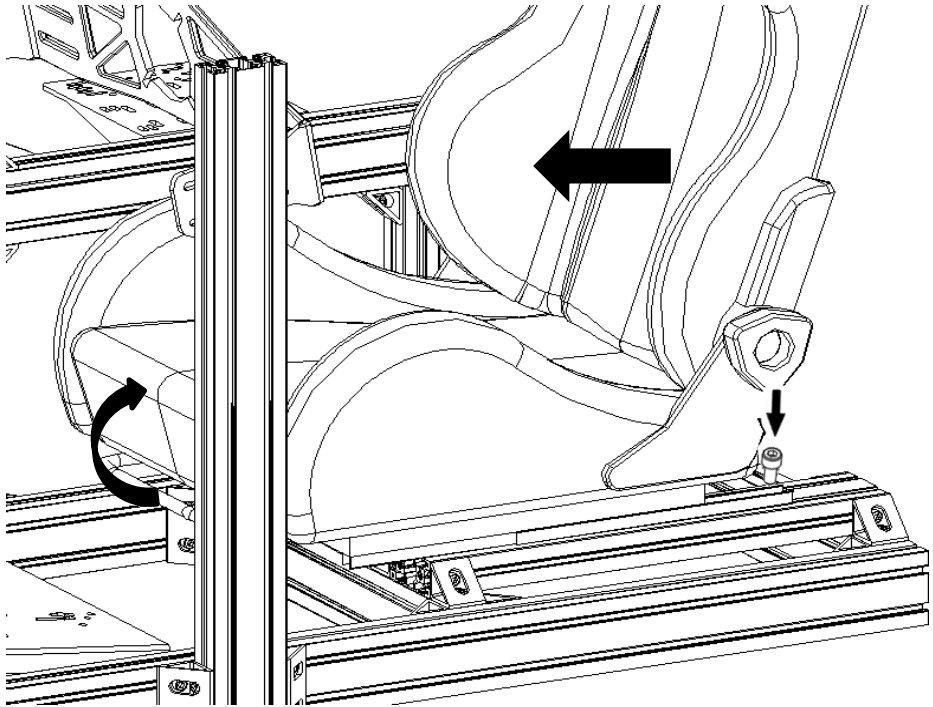
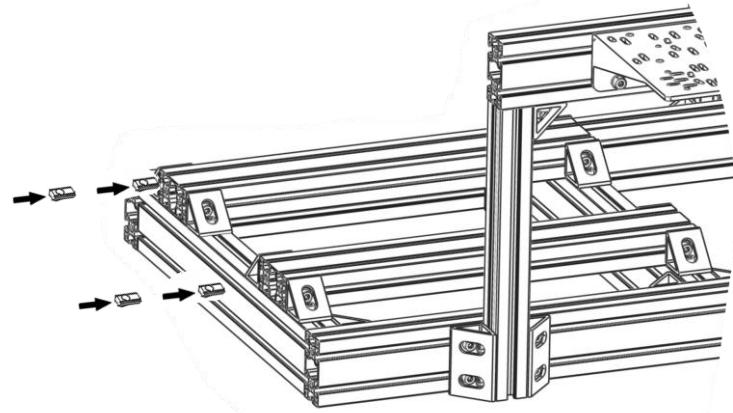
M8x16 x4	M8 Slider x4	Flat, Spring M8 x4
		



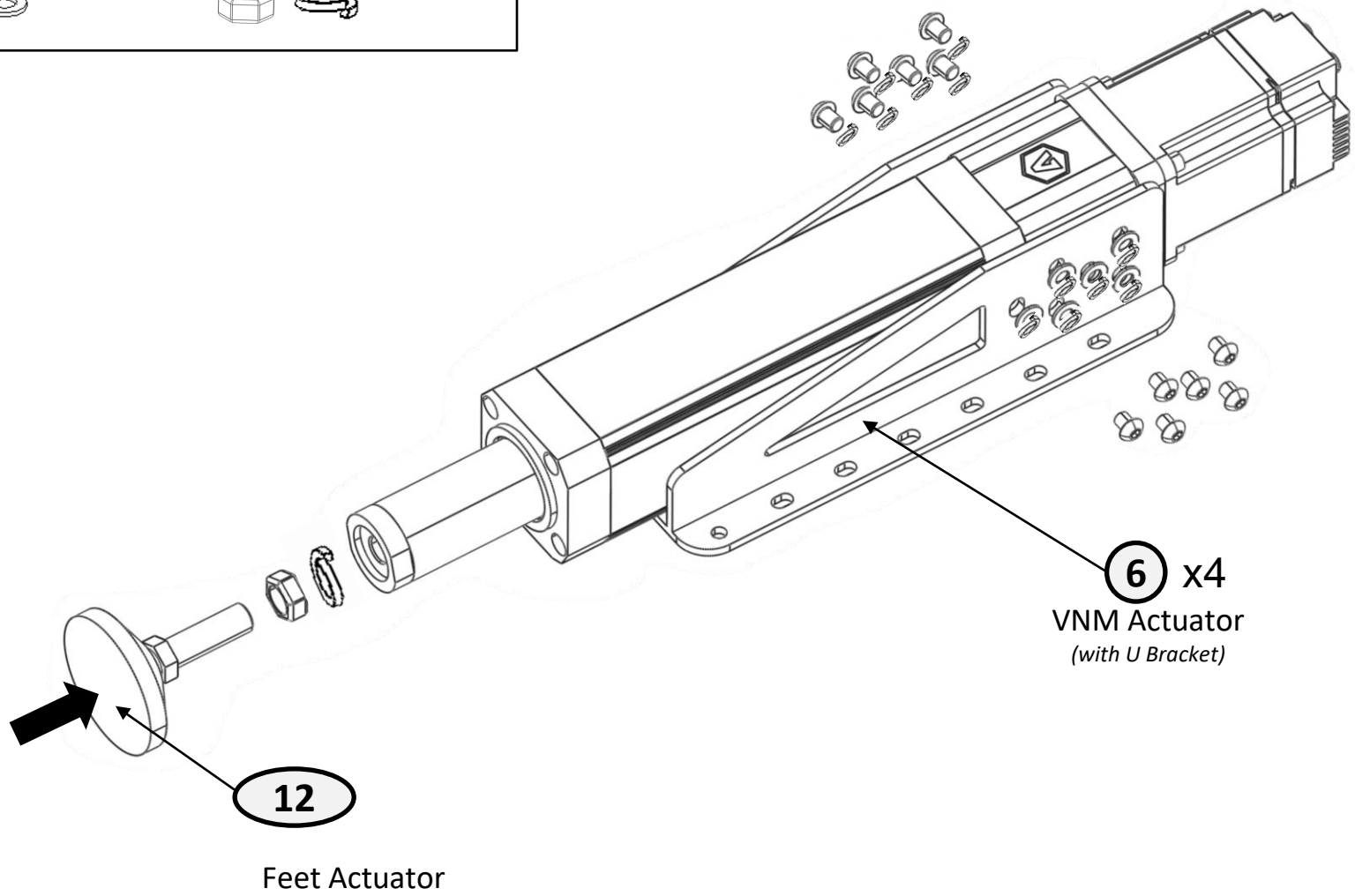

M8x16 x12	Flat, Spring M8 x12	M16 Nuts, Spring M16 x1
		



**12**

Feet Actuator

**6** x4  
VNM Actuator  
(with U Bracket)

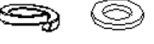
M8x16 x16	M8 Slider x16	Flat, Spring M8 x16
		

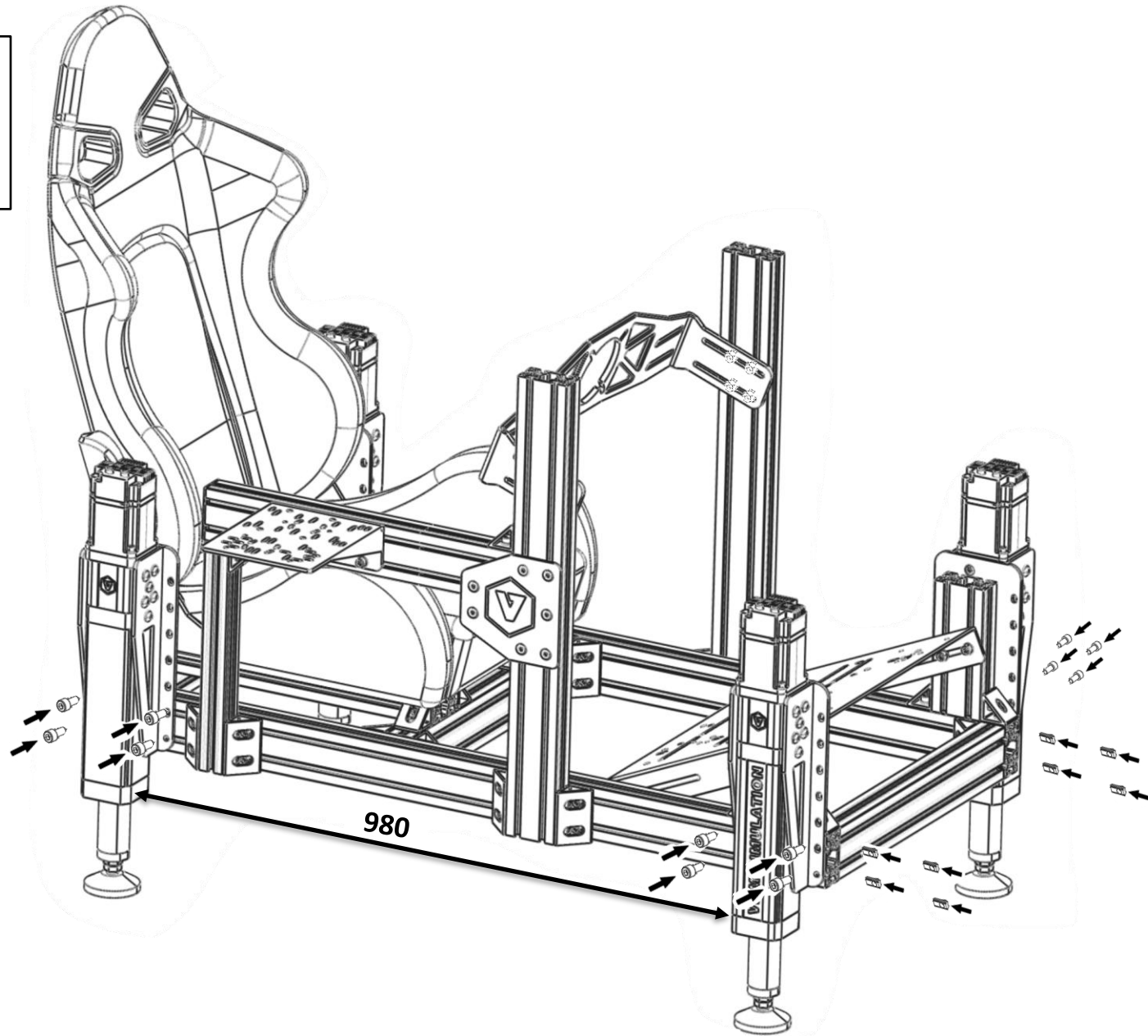

**Tip:** Use rigid blocks of suitable height to support the four corners of the rig for easier installation of the four VNM actuators.

Alu cover  
x13

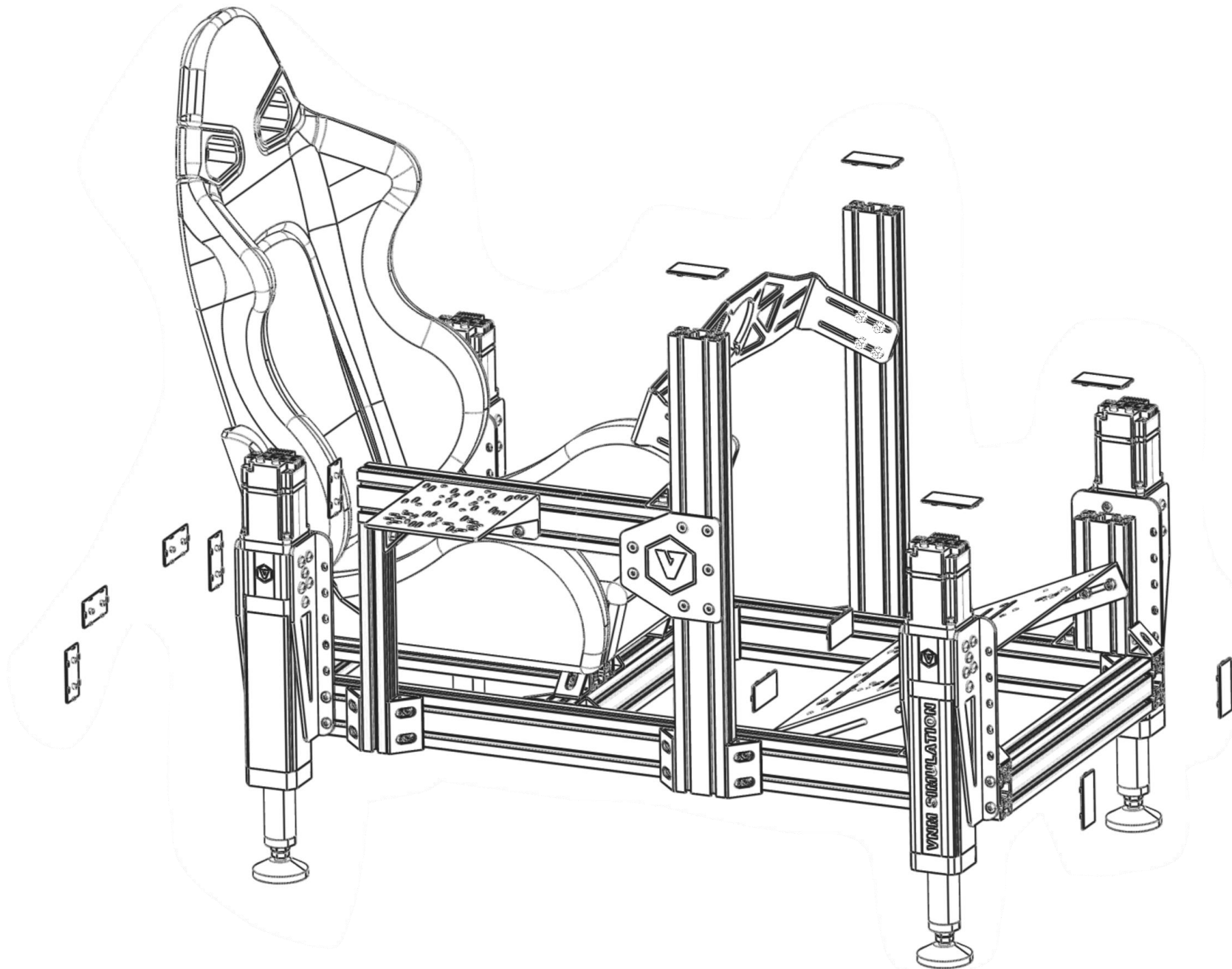

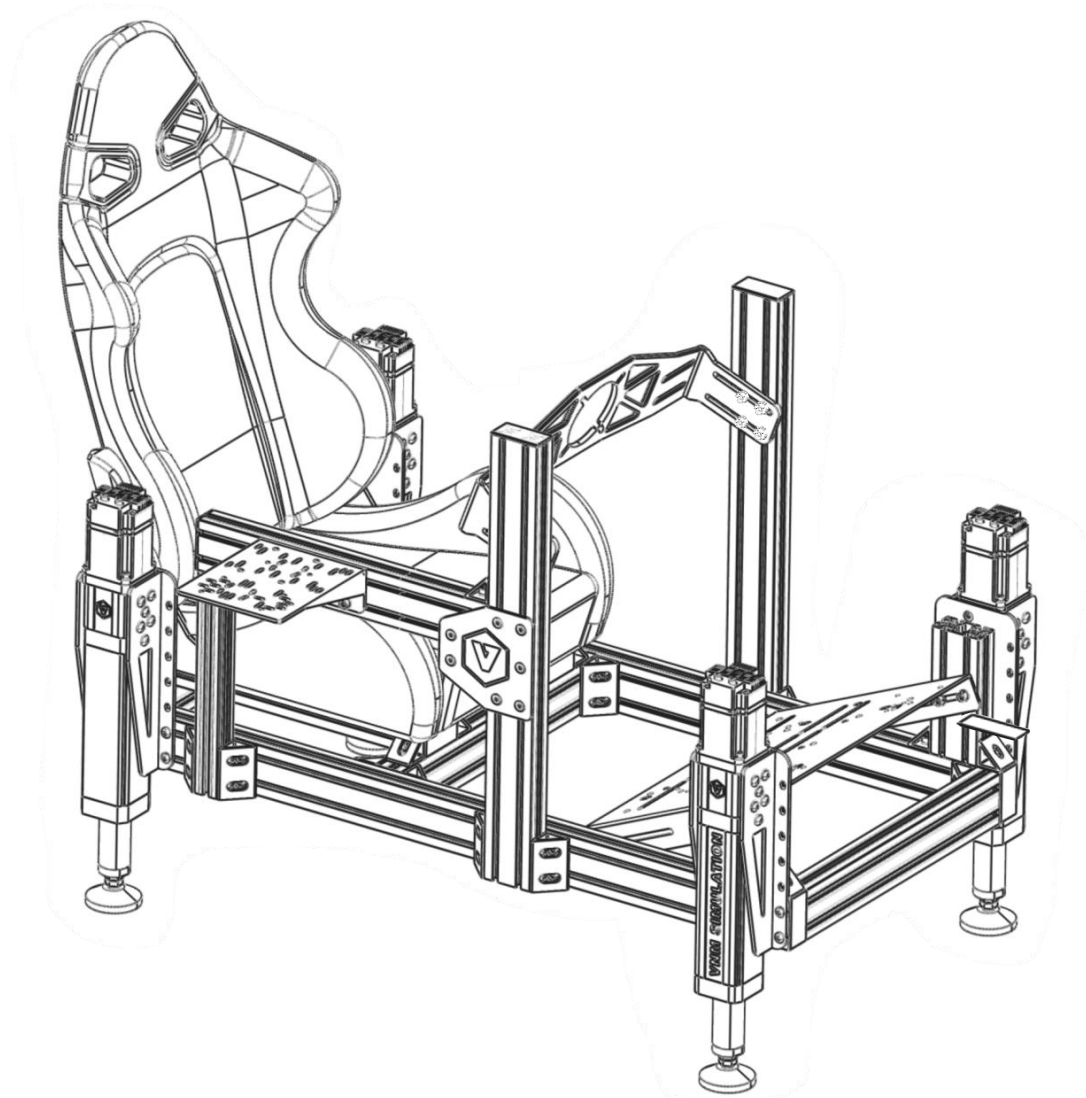

Installation guide  
VNM Surge & TL Platform

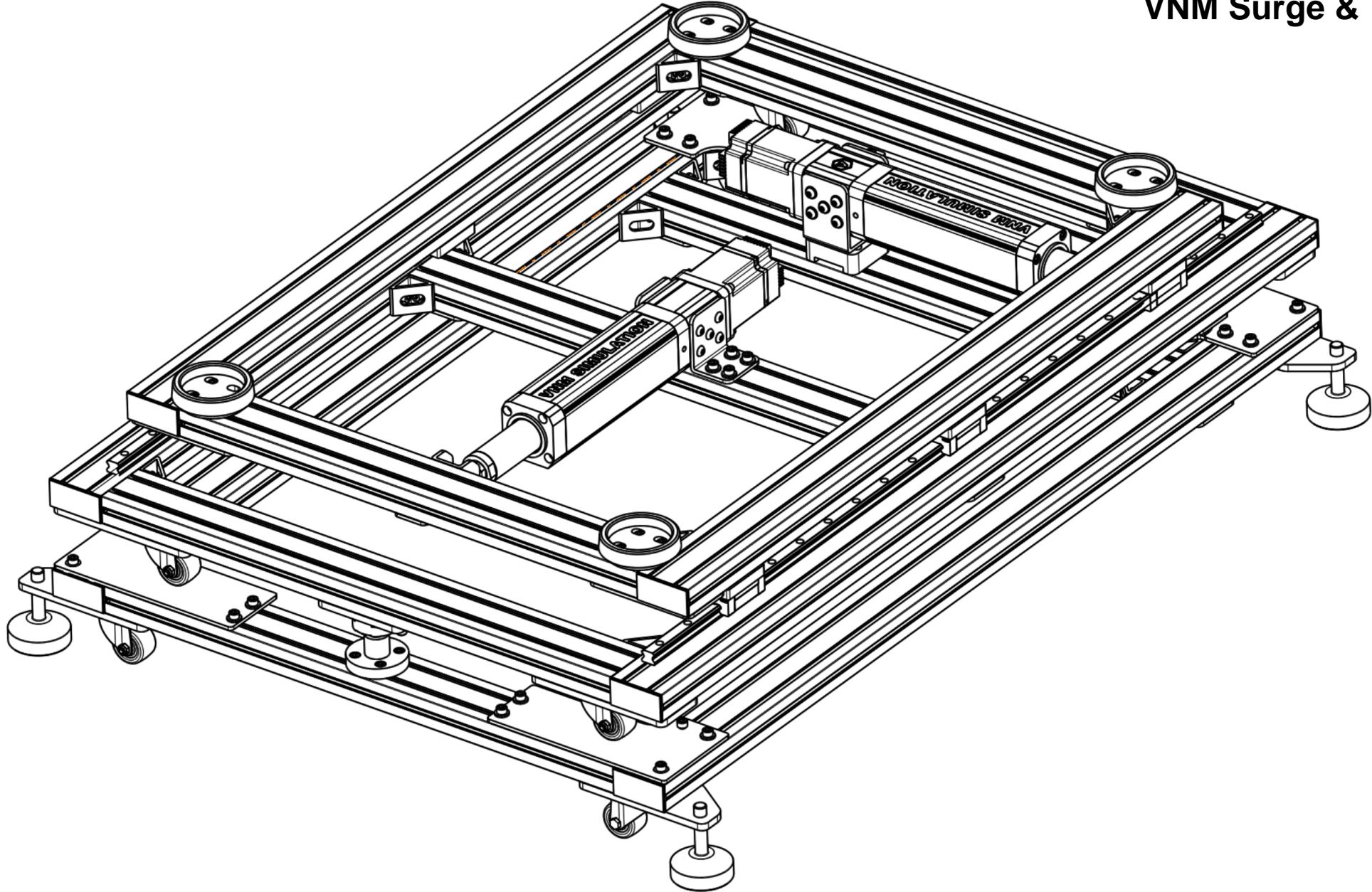

① 40x80x1400  
x4

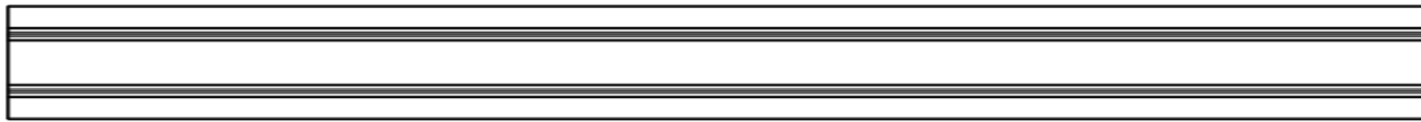

② 40x80x1140  
x2



③ 40x80x800  
x6



④ 40x80x720  
x2

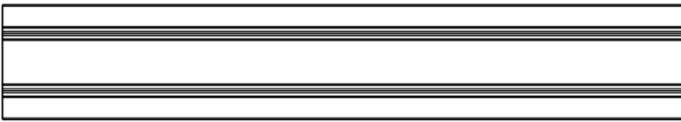

⑤

Actuator Surge  
Bracket  
x1

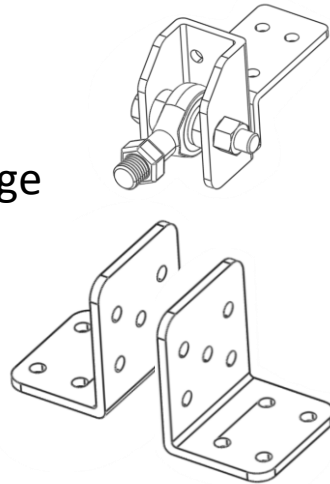

⑥

VNM Actuator 150mm  
x2

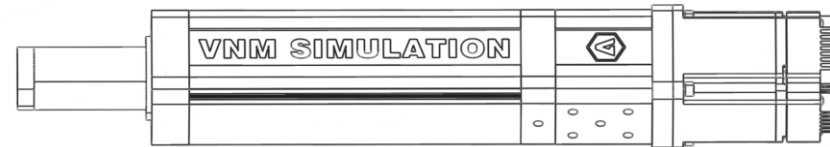

⑦

Actuator  
Tractionless Bracket  
x1

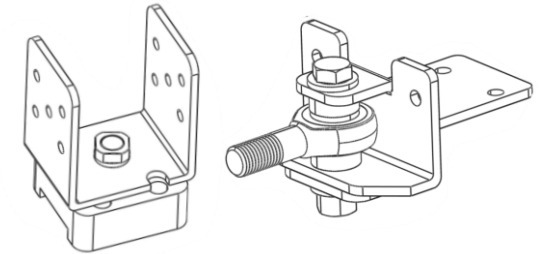

8

### Linear Guide Rail Assembly

1300mm

x2



9

Foot Motion

x4

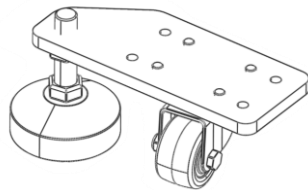

10

Spindle & UCFL204

x1

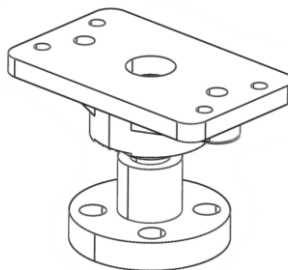

11

Low Gravity

x4

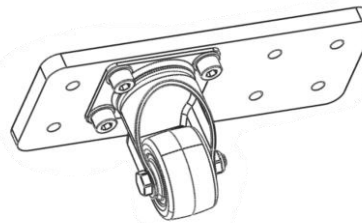

12

D100 Cup

x4

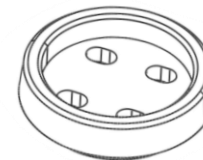

13

Wheel Support Bracket

x4

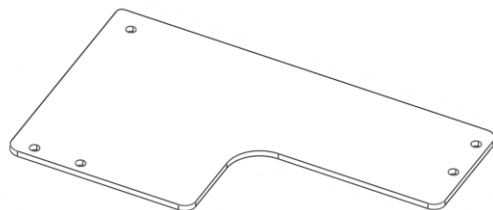

14

4040 Conner Alu

x20

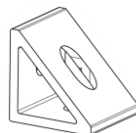

15

Connector Plate I

x8

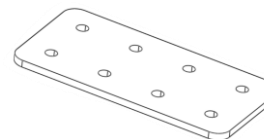

16

Alu Cover

x12

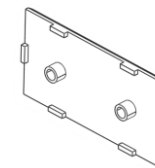

# Method 1

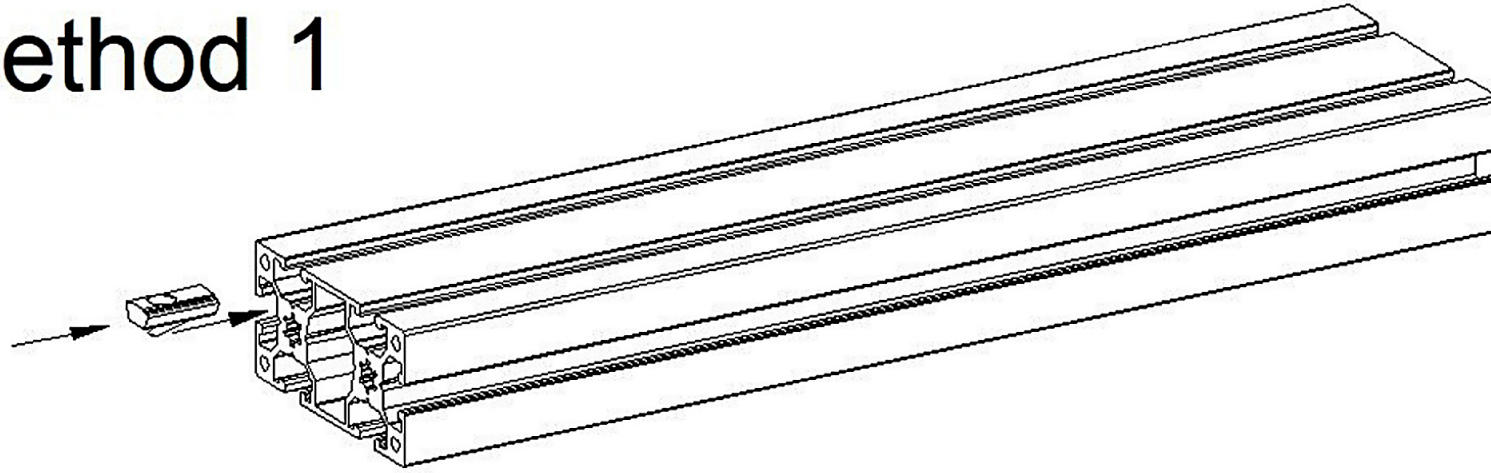

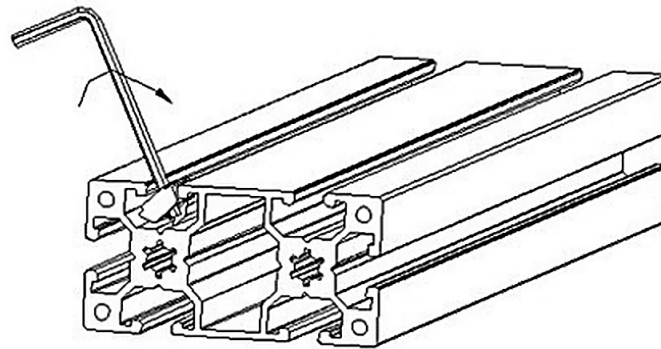

# Method 2

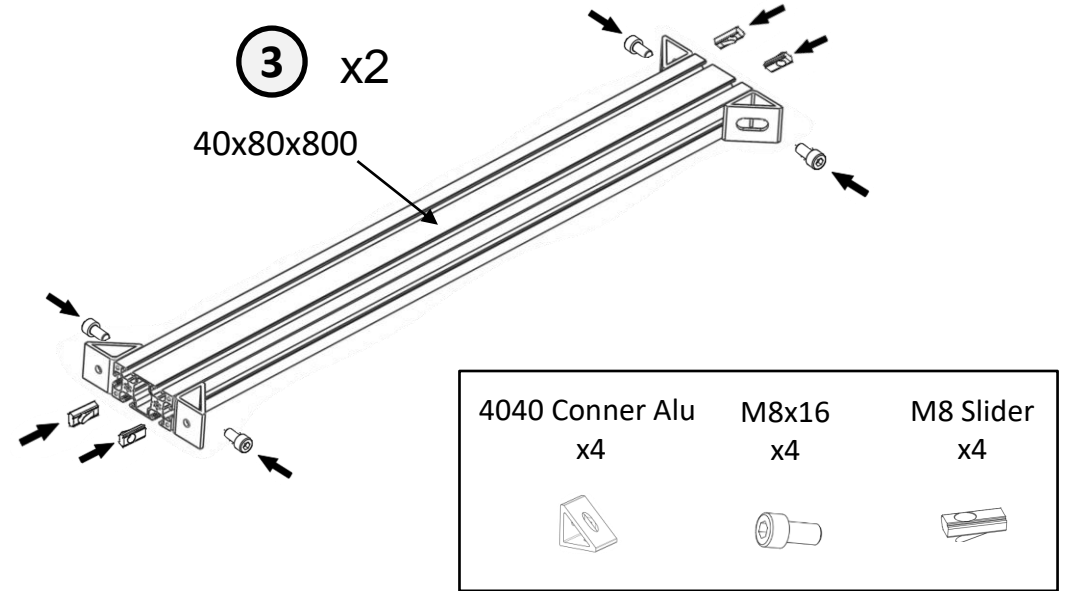
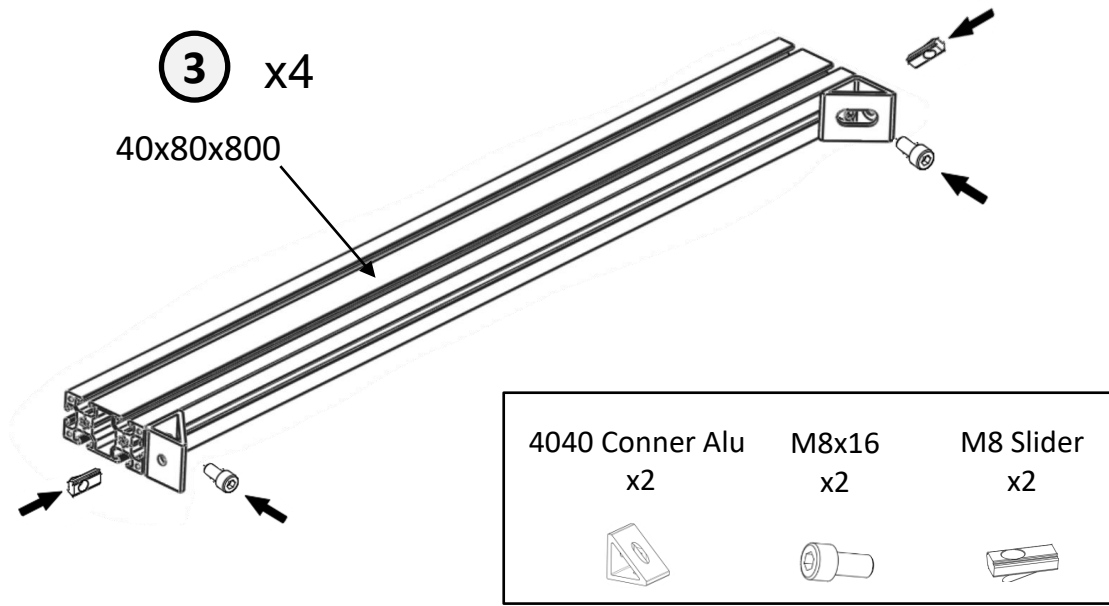

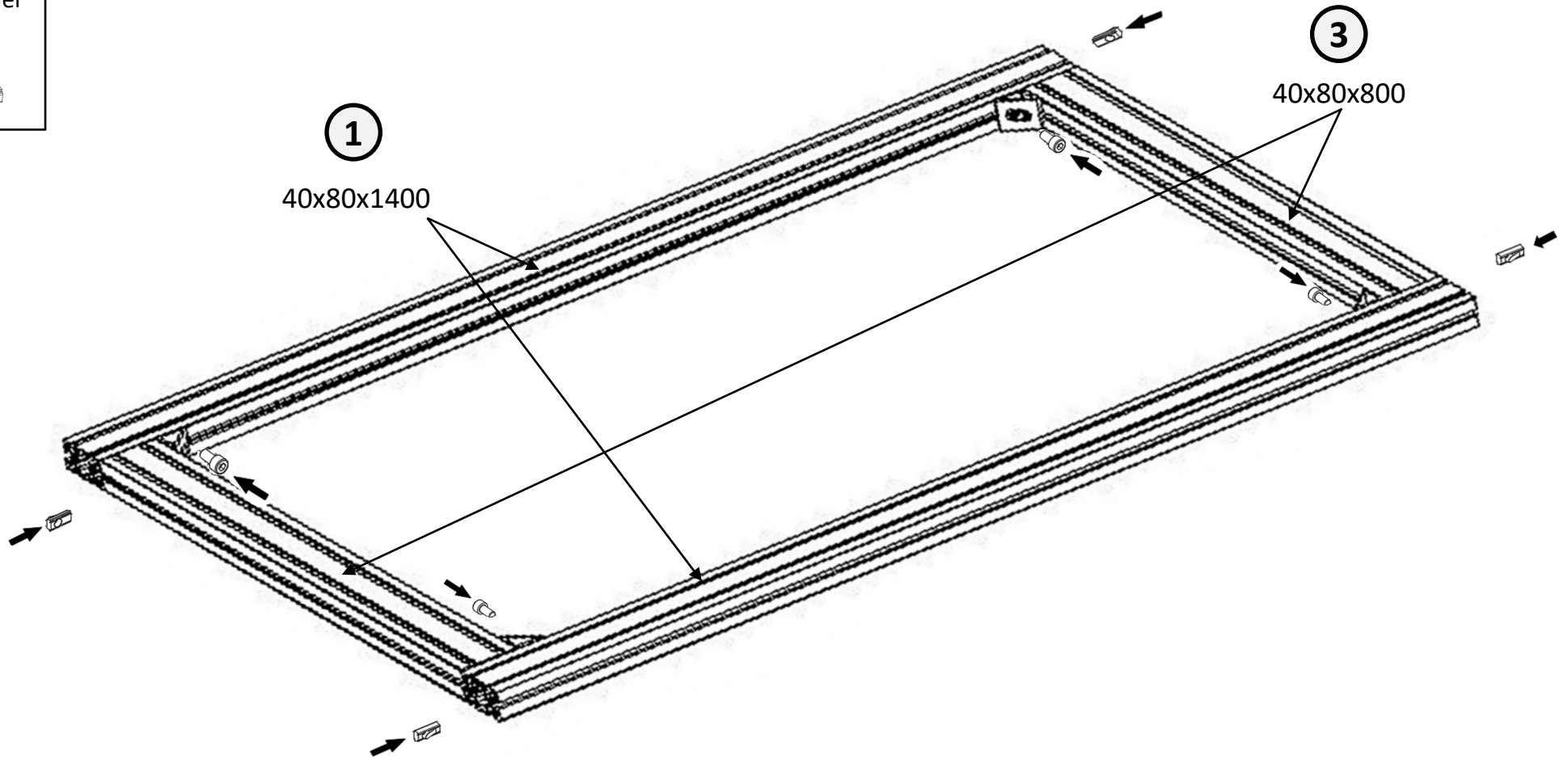
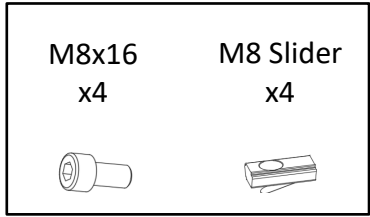





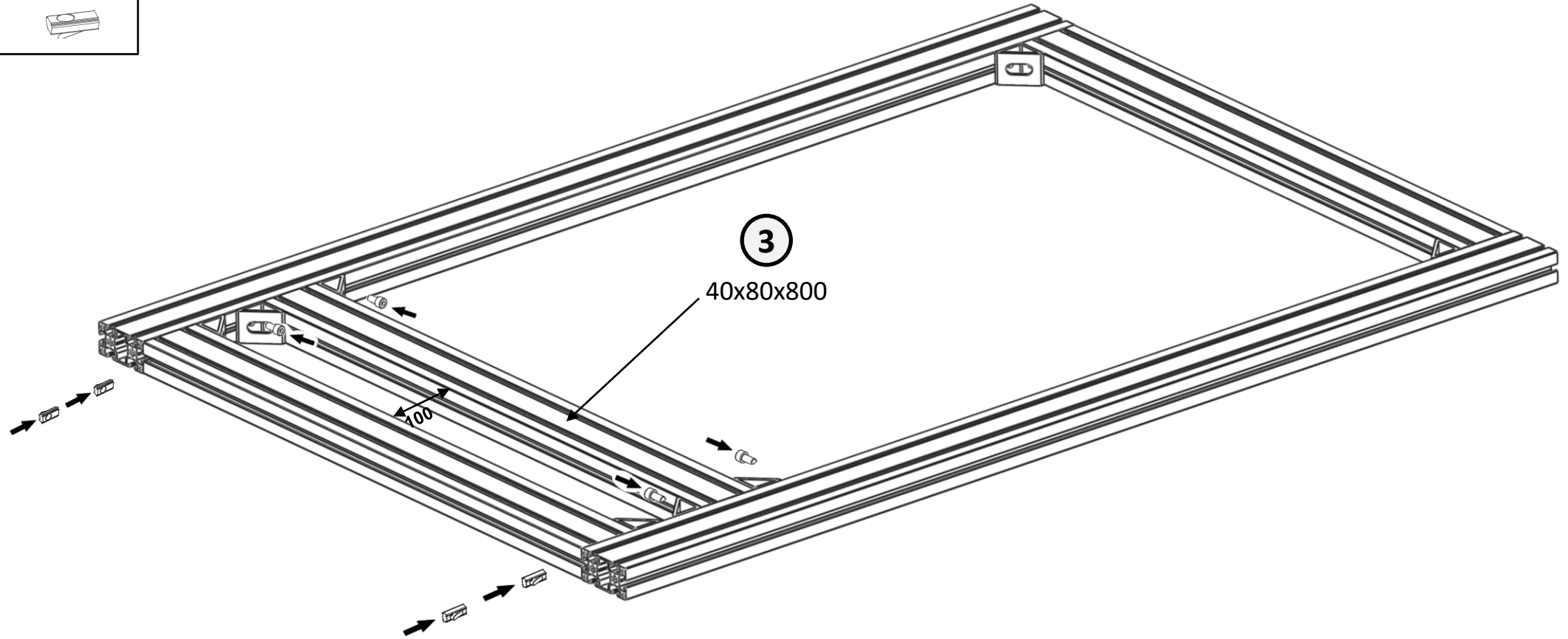





M8x16 x4	M8 Slider x4
	

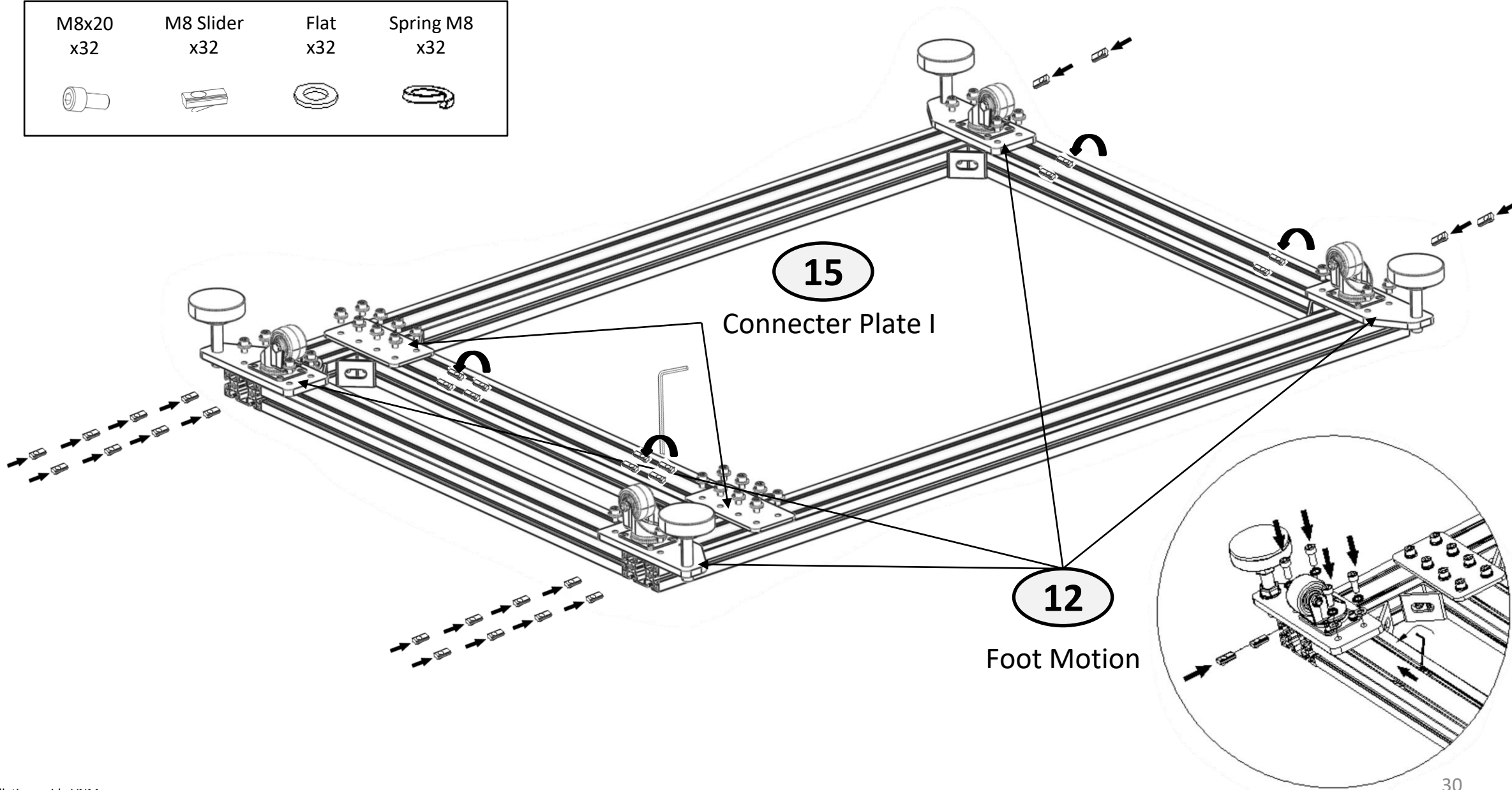

M8x20 x32	M8 Slider x32	Flat x32	Spring M8 x32
			



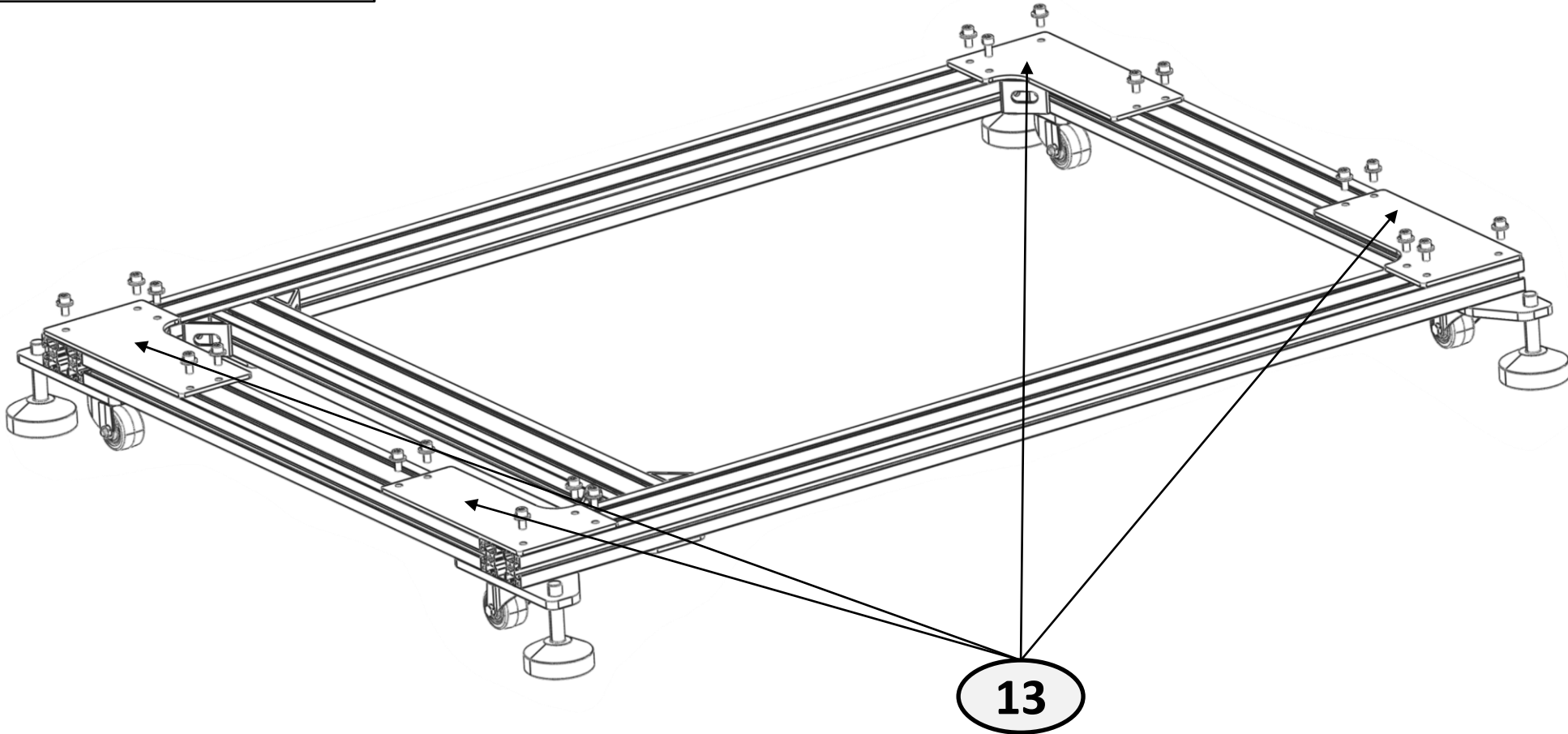

M8x16 x20	M8 Slider x20	Flat x20	Spring M8 x20
			



**13**  
Wheel Support Bracket



10

Spindle & UCFL204

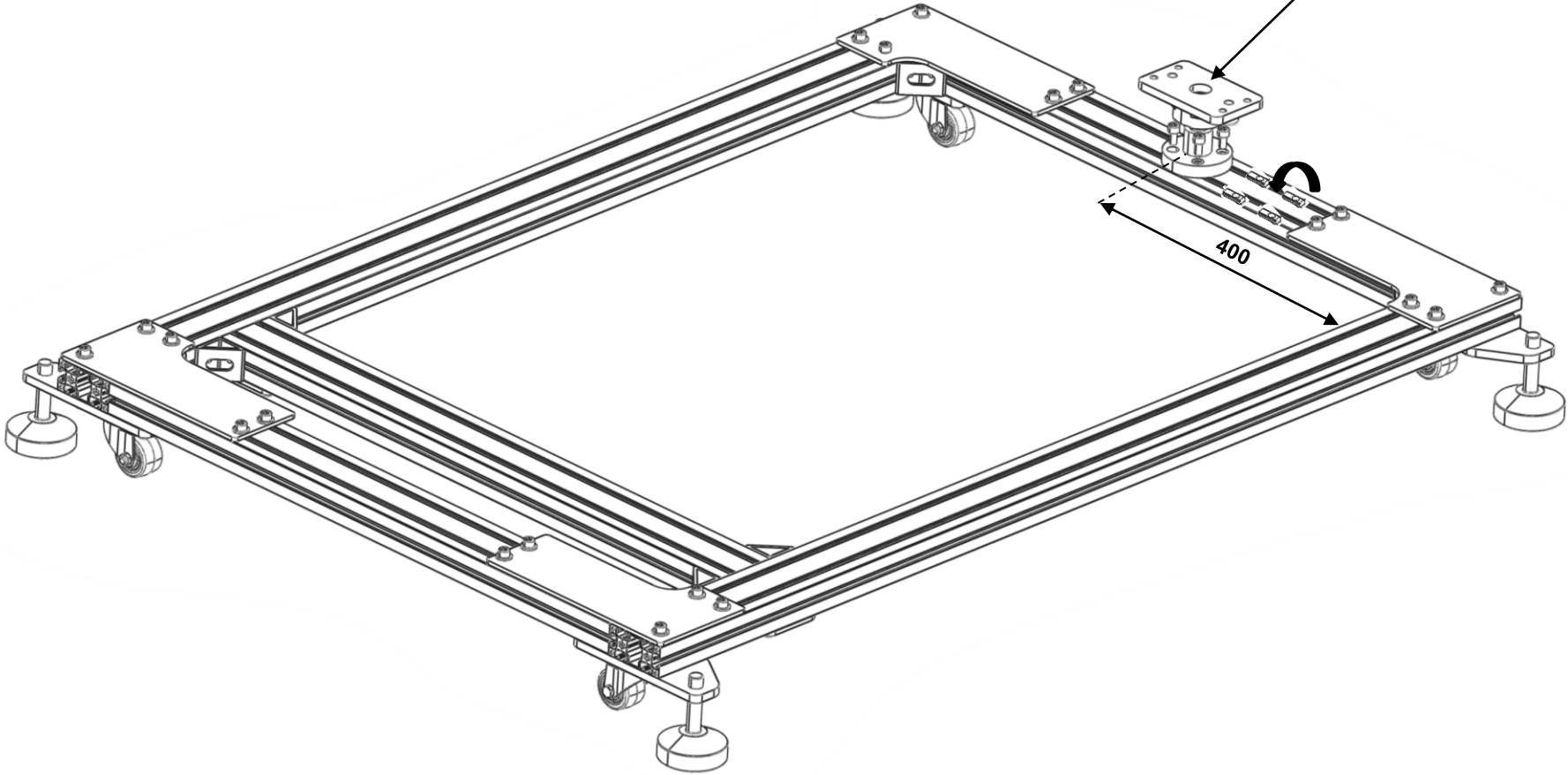
M8x16 x4	Spring M8 x4	M8 Slider x4
		



Fully tighten the screws at this step.



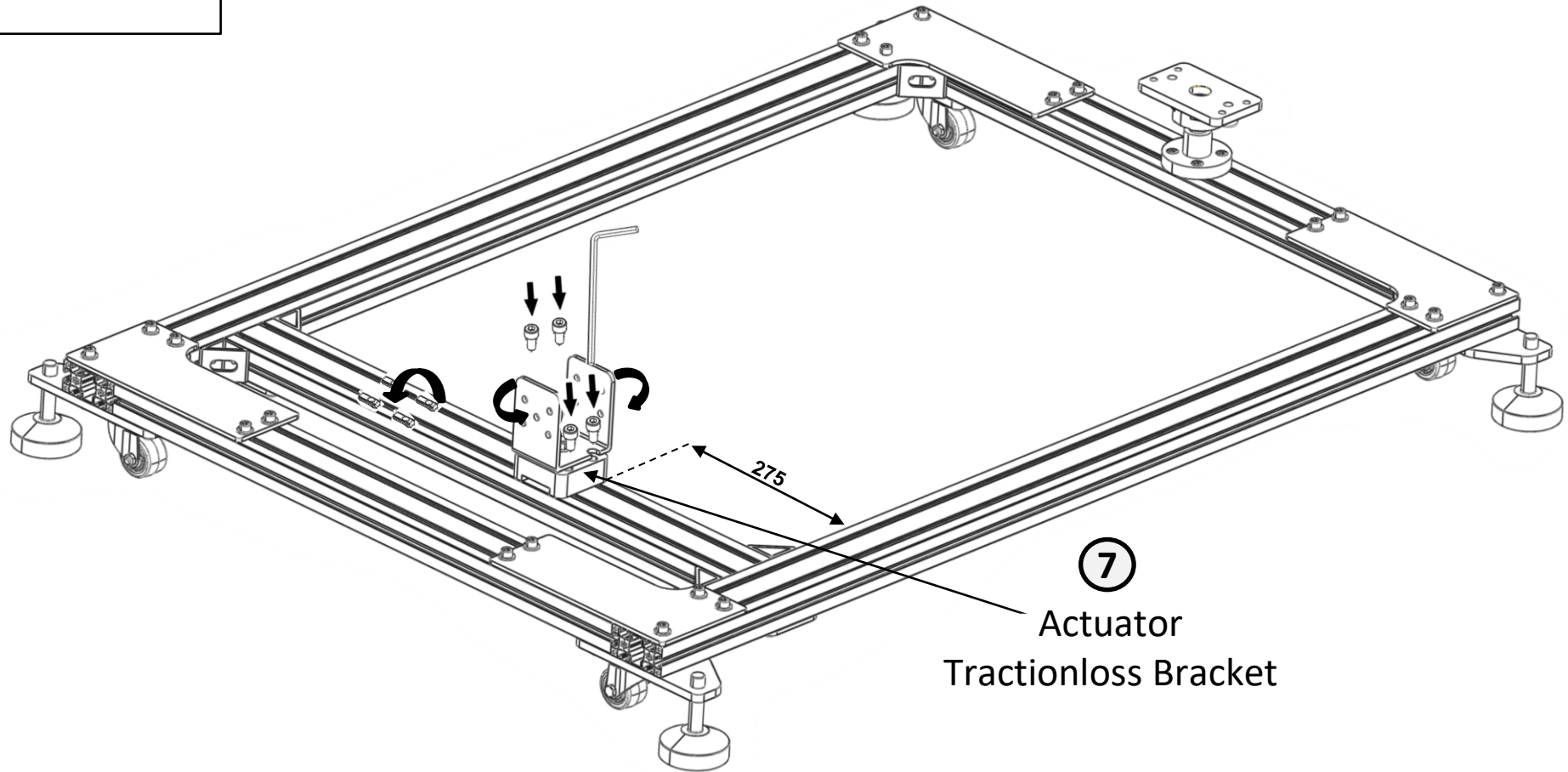

M8x20 x4	Spring M8 x4	M8 Slider x4
		



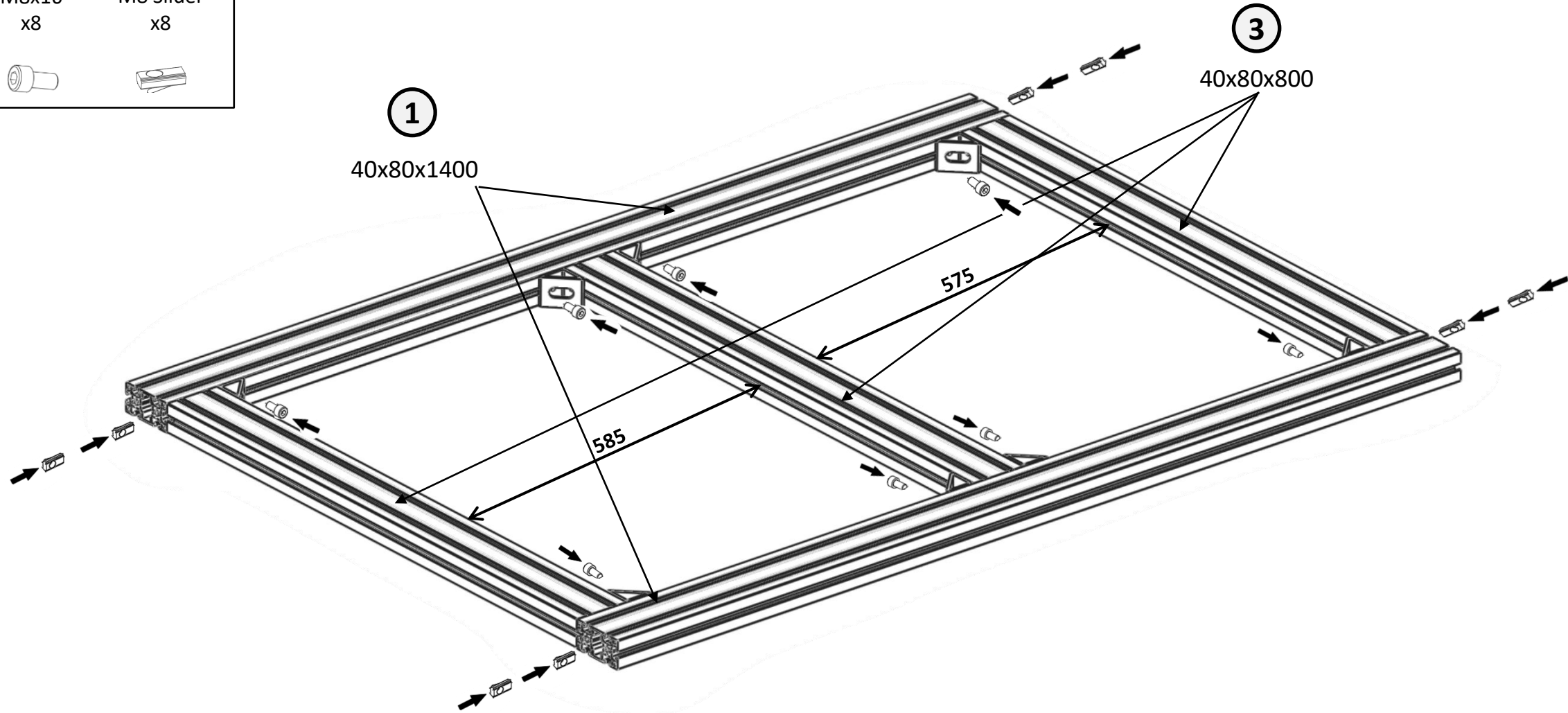
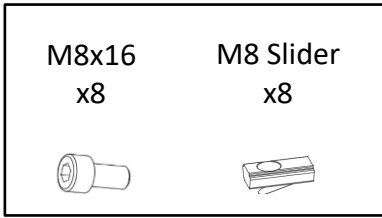



⑦  
Actuator  
Tractionless Bracket

**Fully tighten** the screws at this step

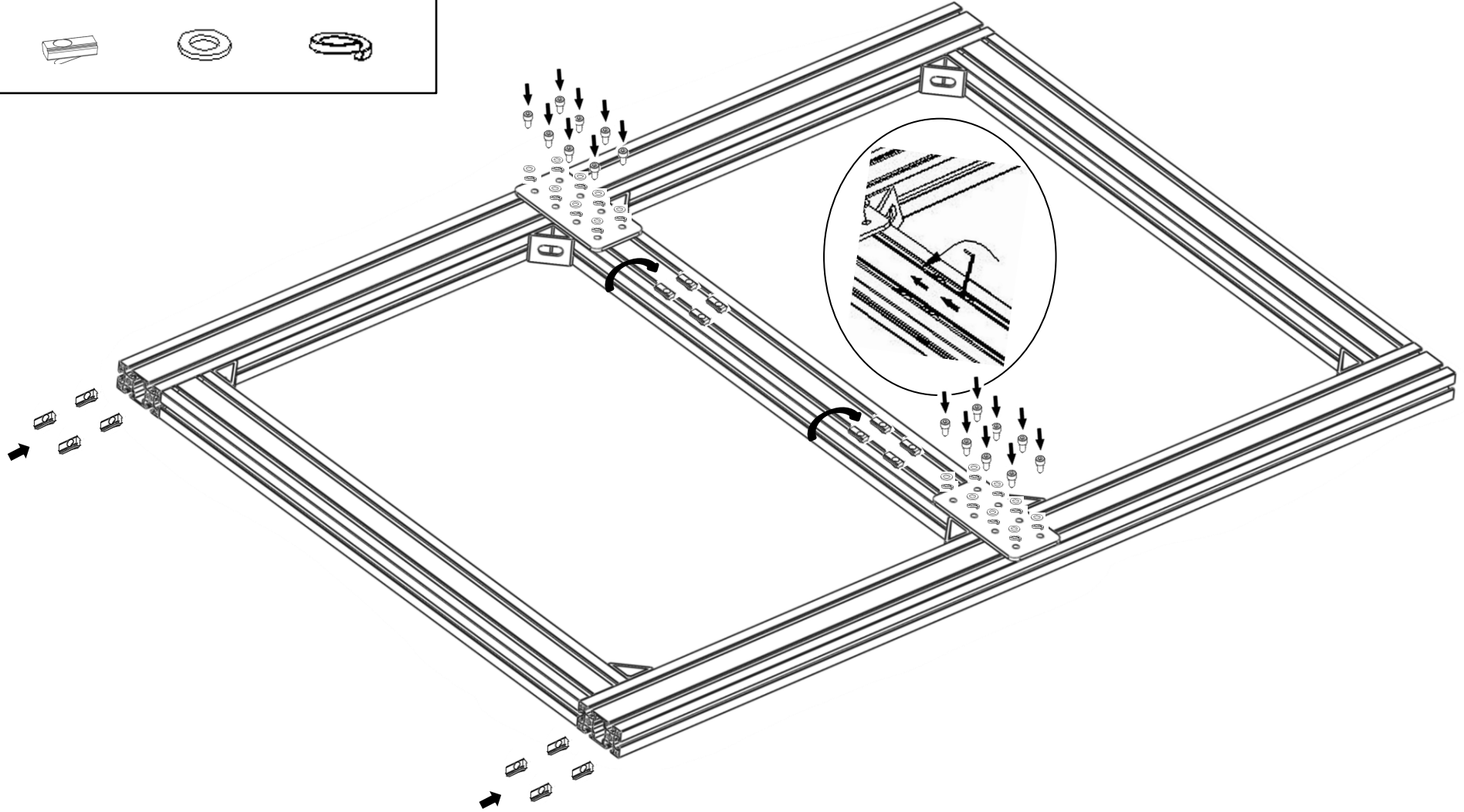



M8x16 x16	M8 Slider x16	Flat x16	Spring M8 x16
			

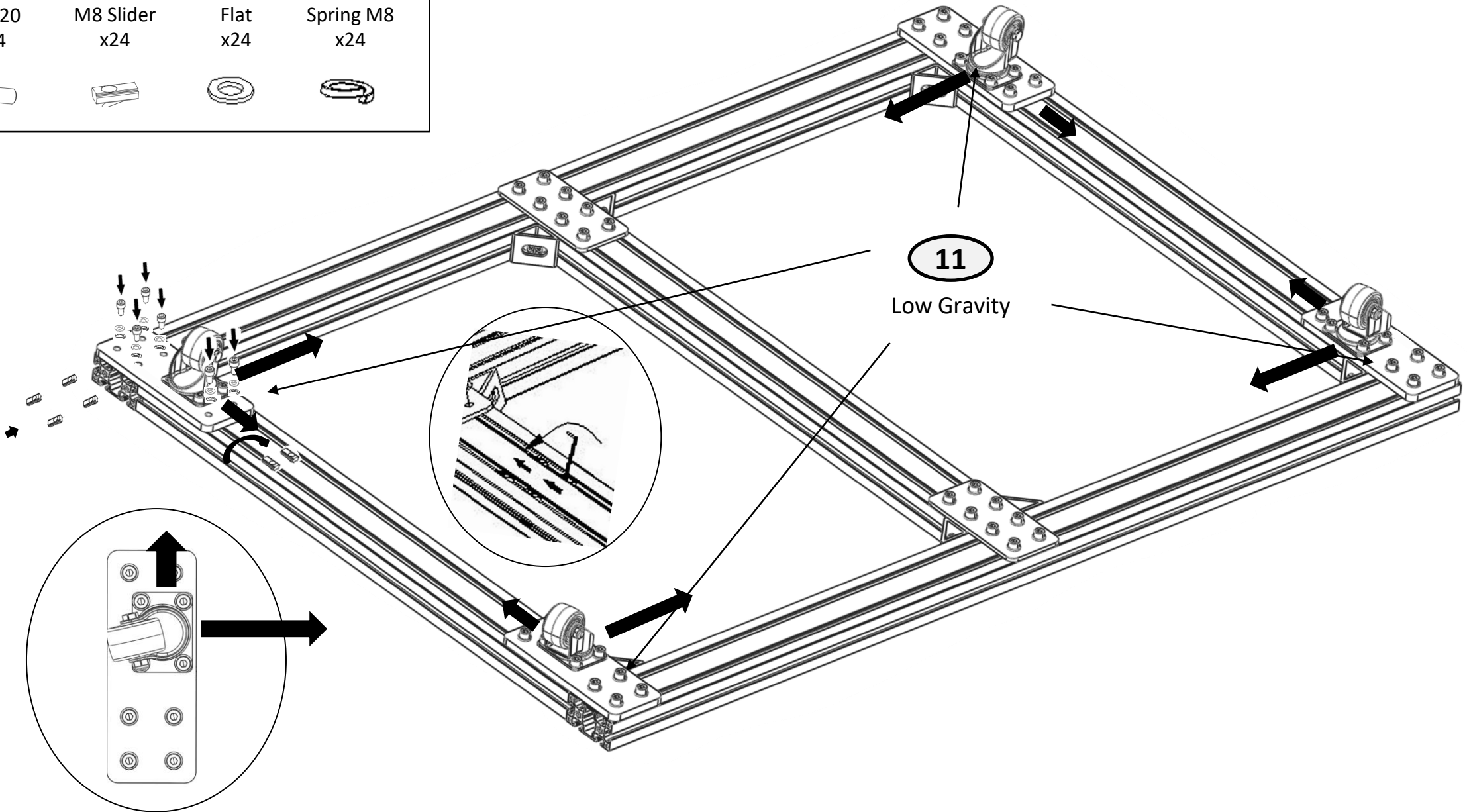

M8x20 x24	M8 Slider x24	Flat x24	Spring M8 x24
			



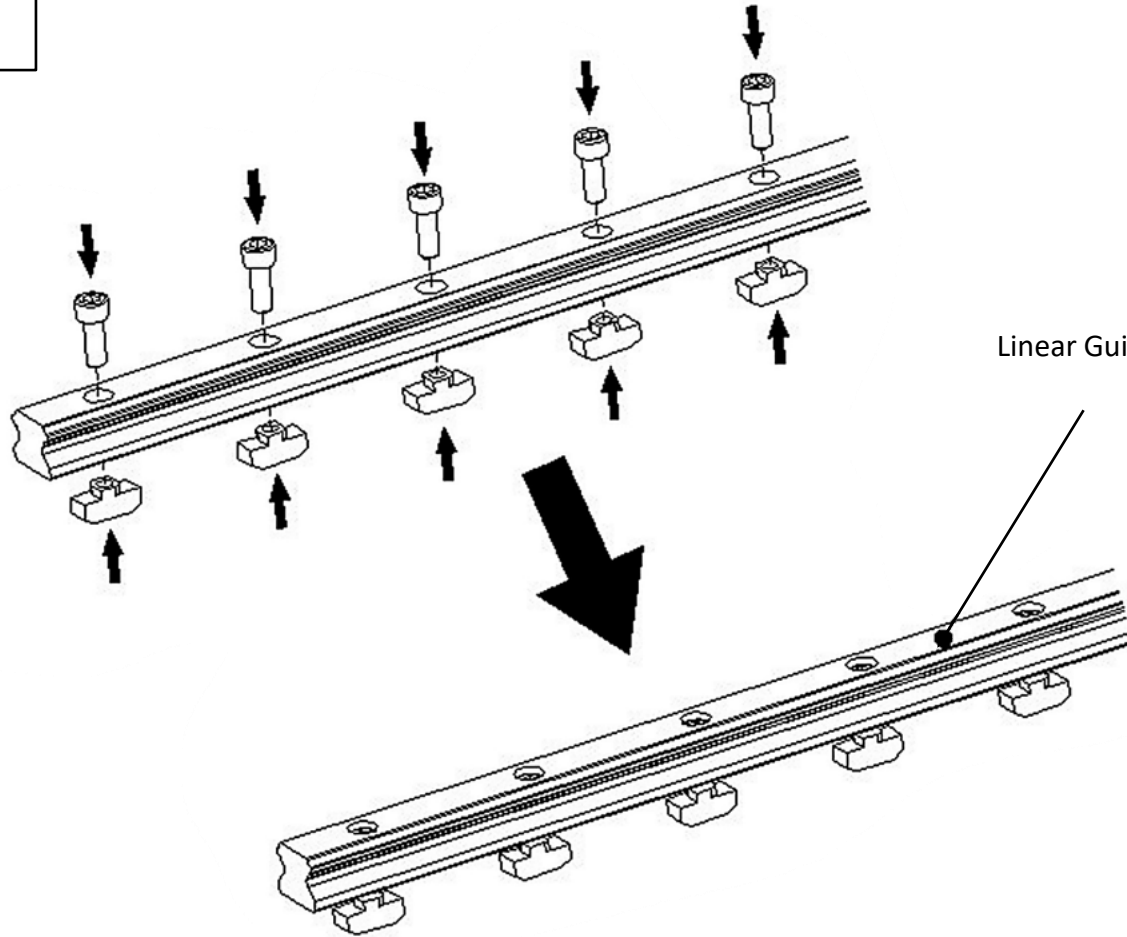

M6x16 x22	T Nut M6 x22
	





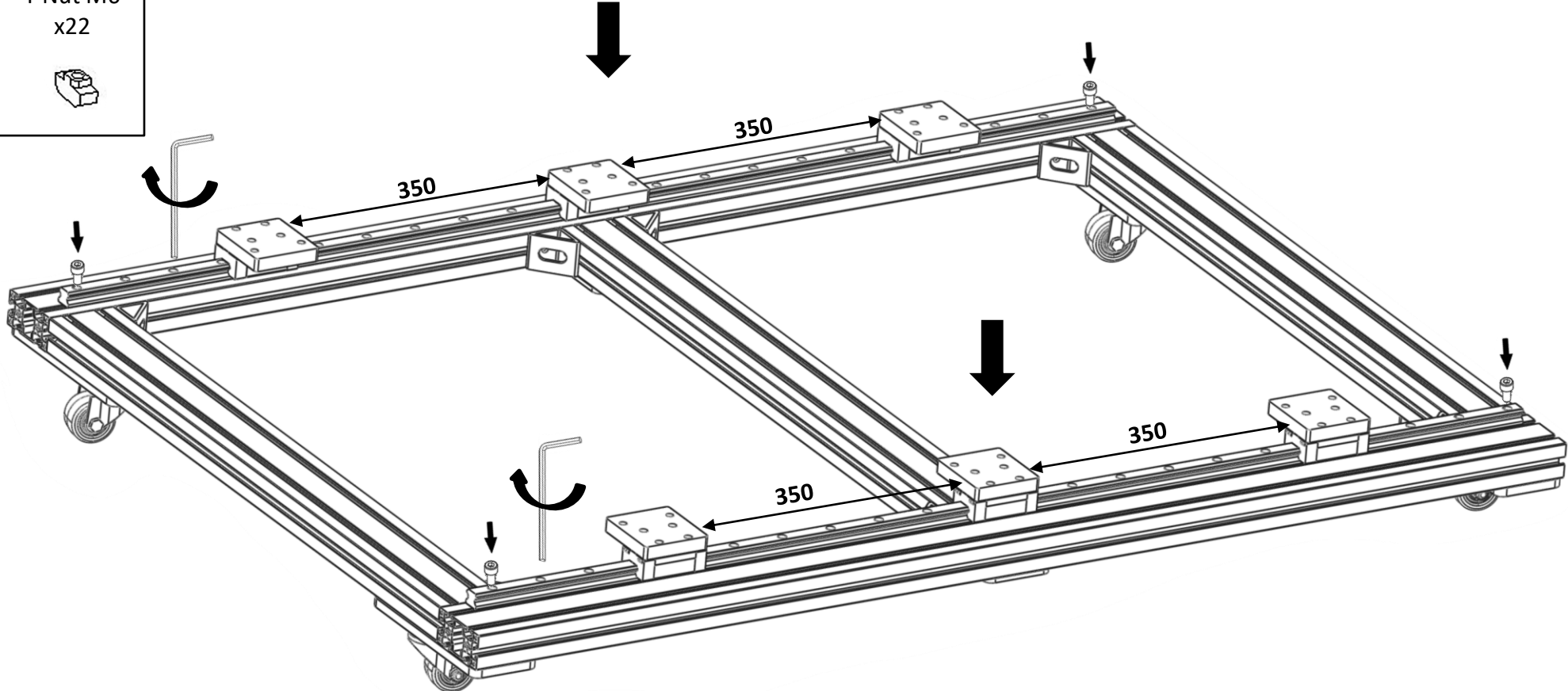

8

Linear Guide Rail Assembly 1300mm

M6x16 x22	T Nut M6 x22
	





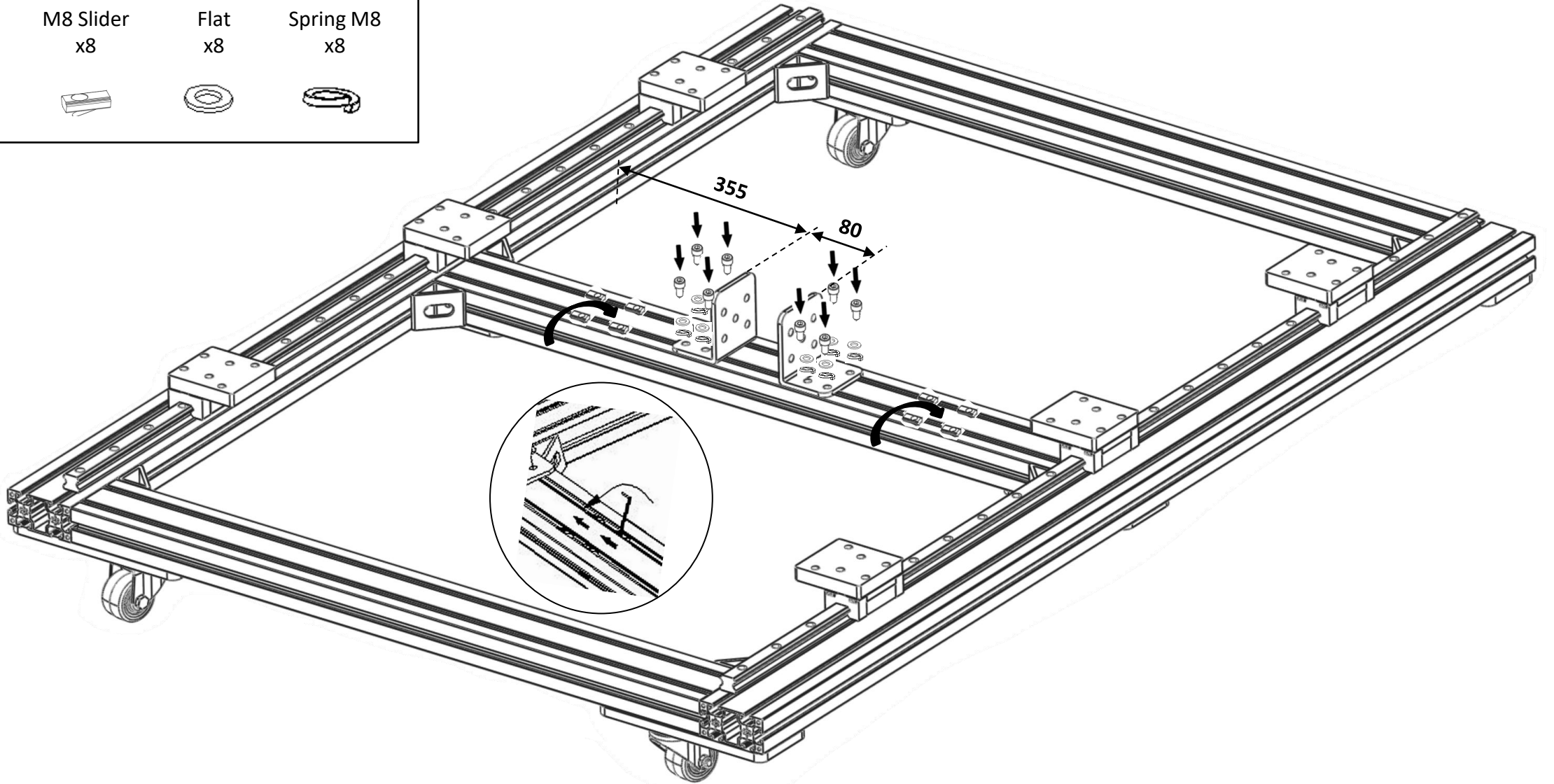

Install M8 screws at both ends of the rail **to prevent the carriage from sliding off.**

M8x16 x8	M8 Slider x8	Flat x8	Spring M8 x8
			

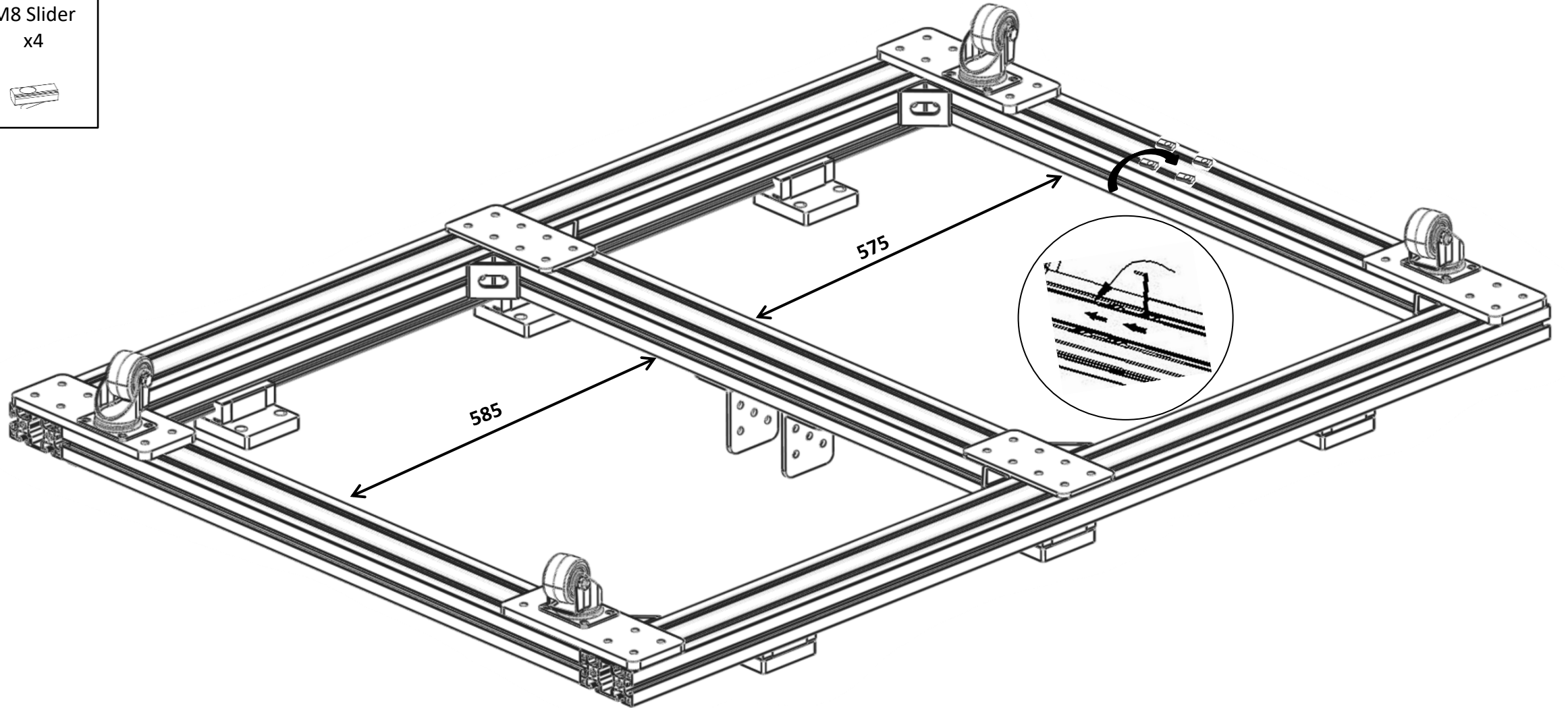



M8 Slider  
x4

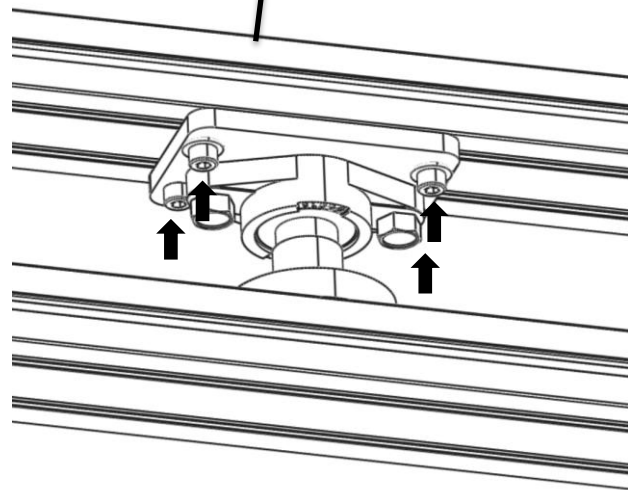
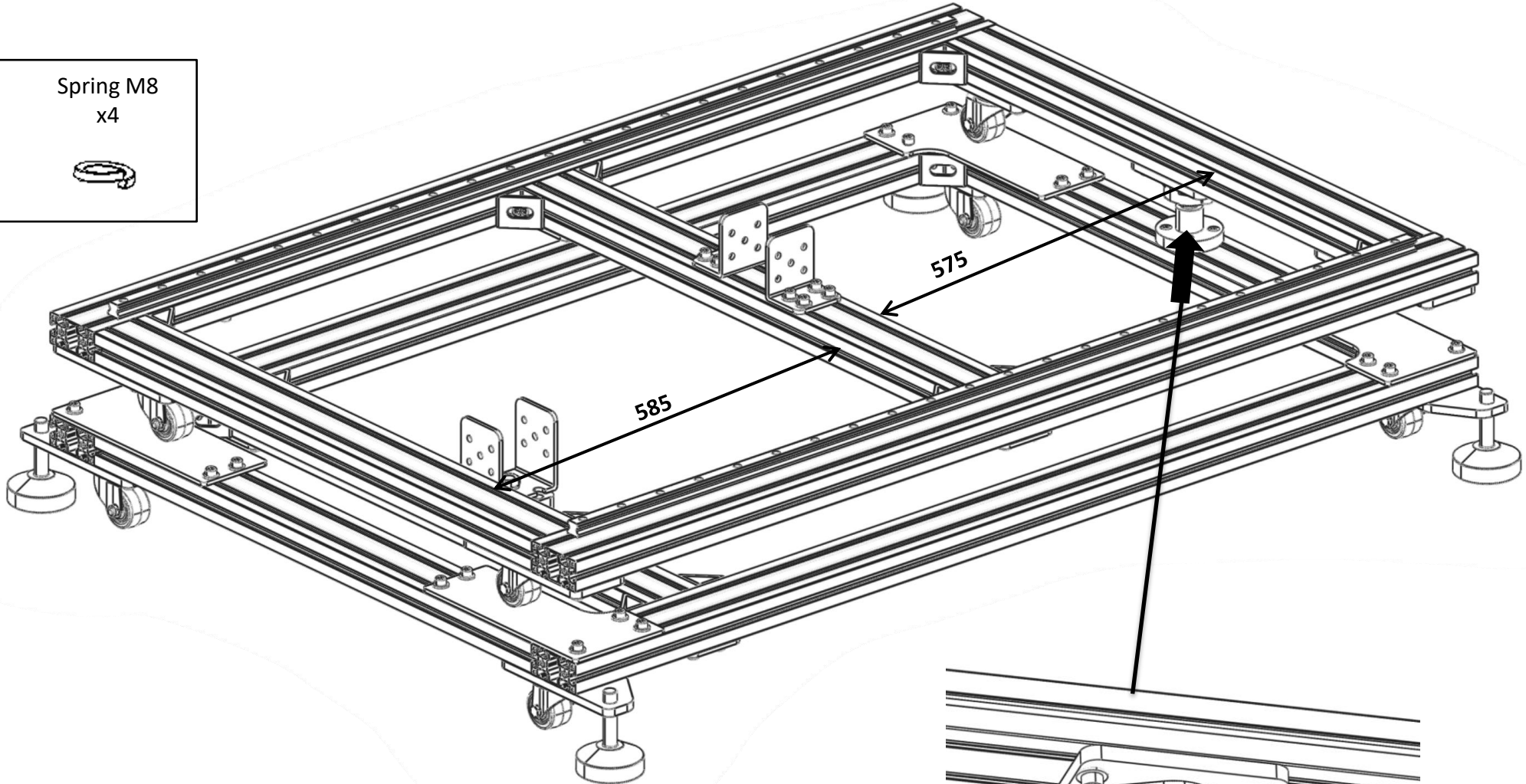

M8x20 x4	Flat x4	Spring M8 x4
		



Nut M16 x1	Spring M16 x1
	

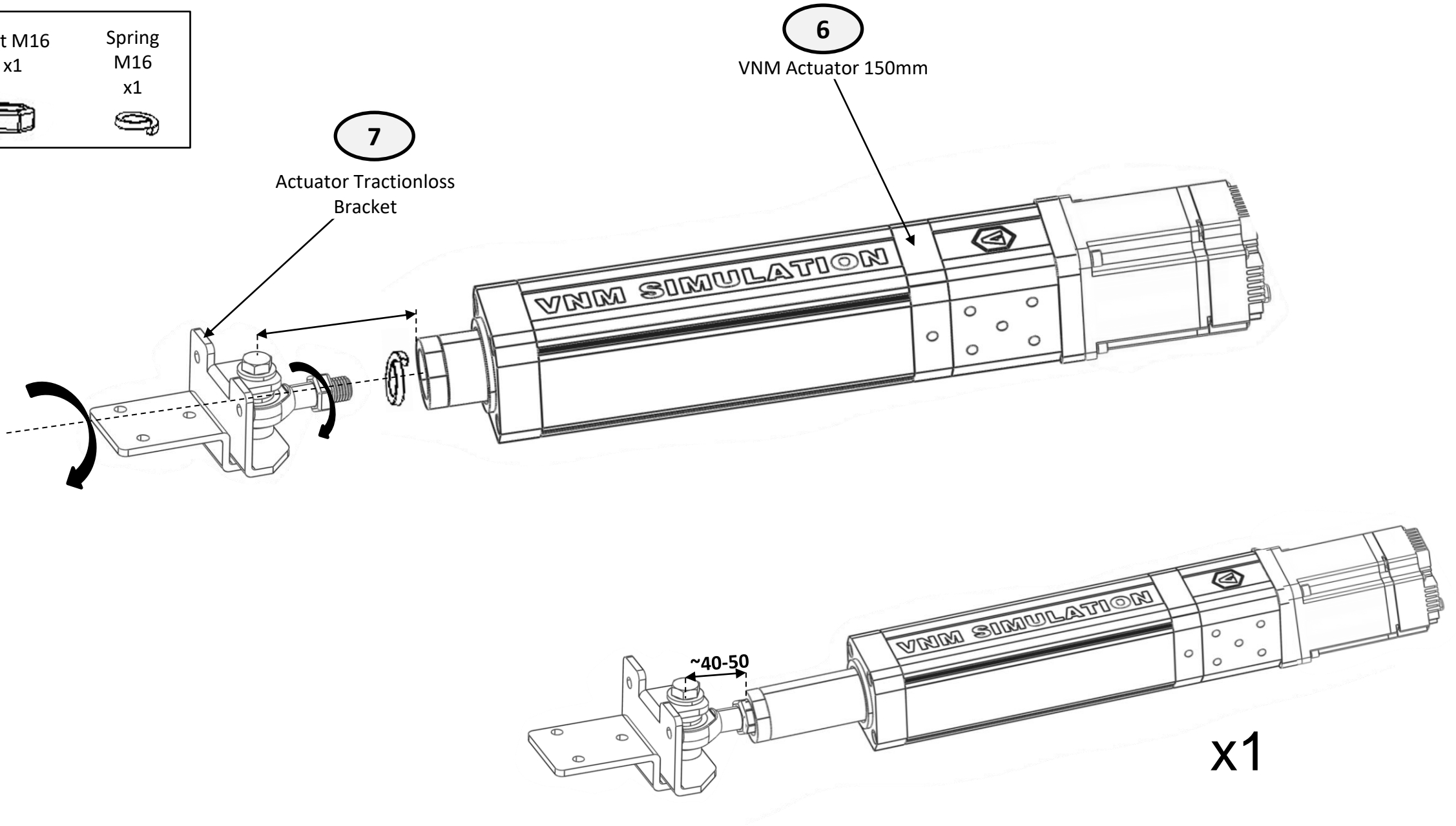

M8x16  
x5



M8 Slider  
x5



Flat  
x15





Spring M8  
x15

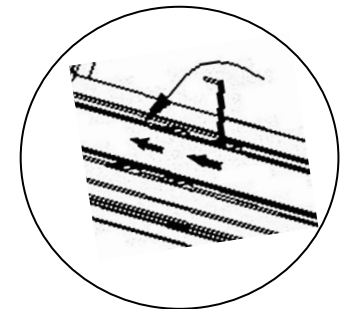
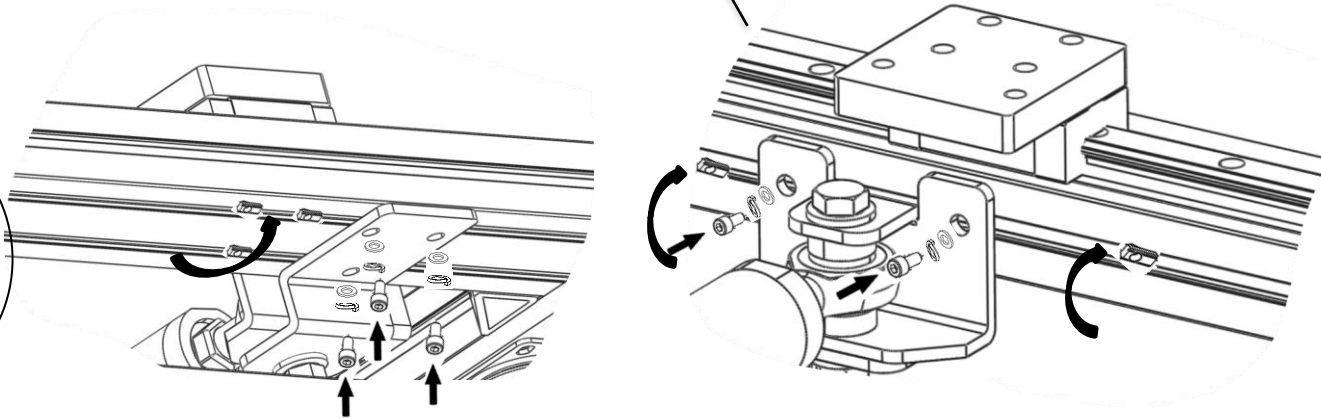
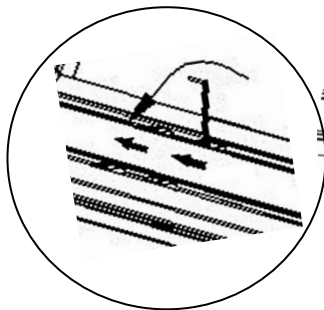
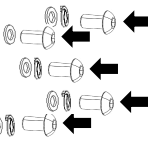
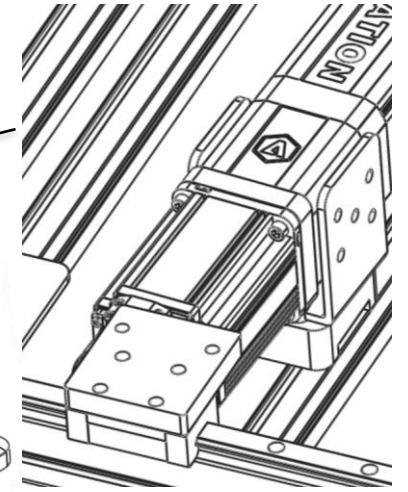
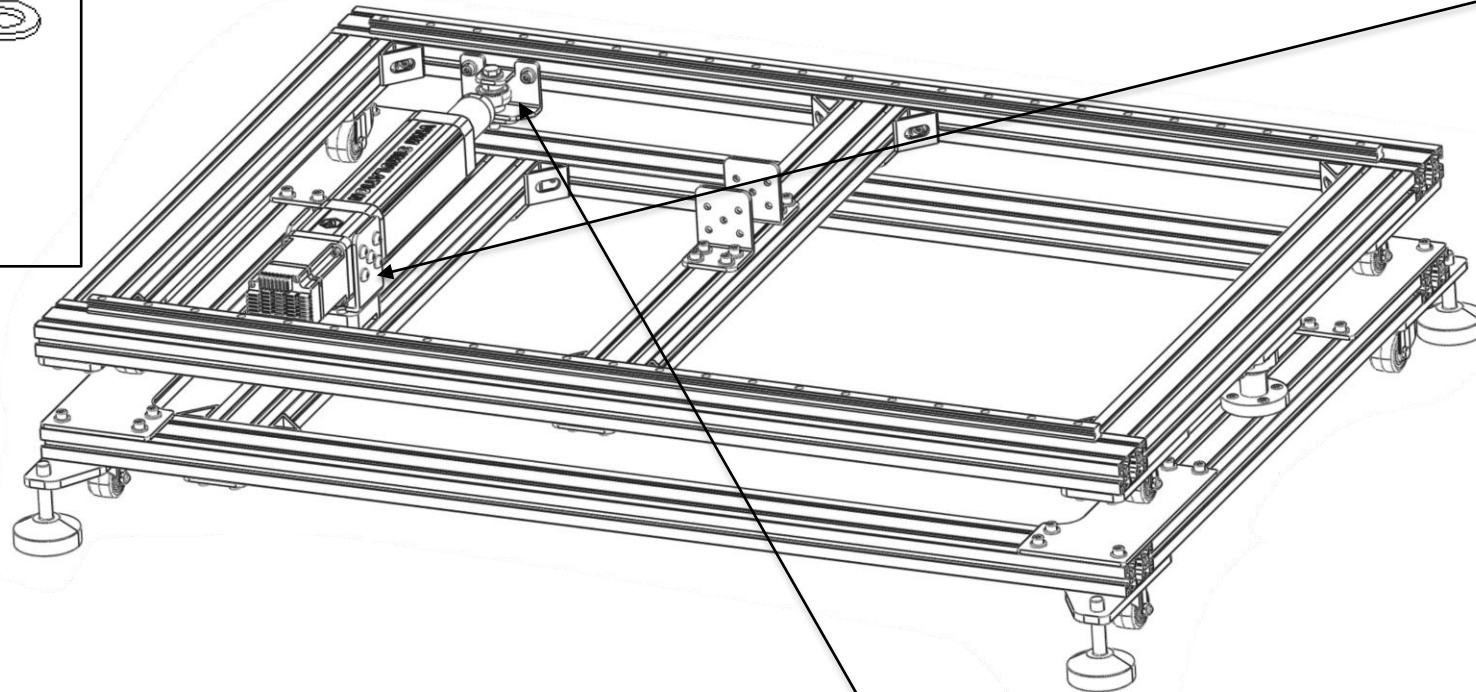

Mo M8x16  
x10



4040 Conner Alu x2	M8x16 x2	M8 Slider x2
		

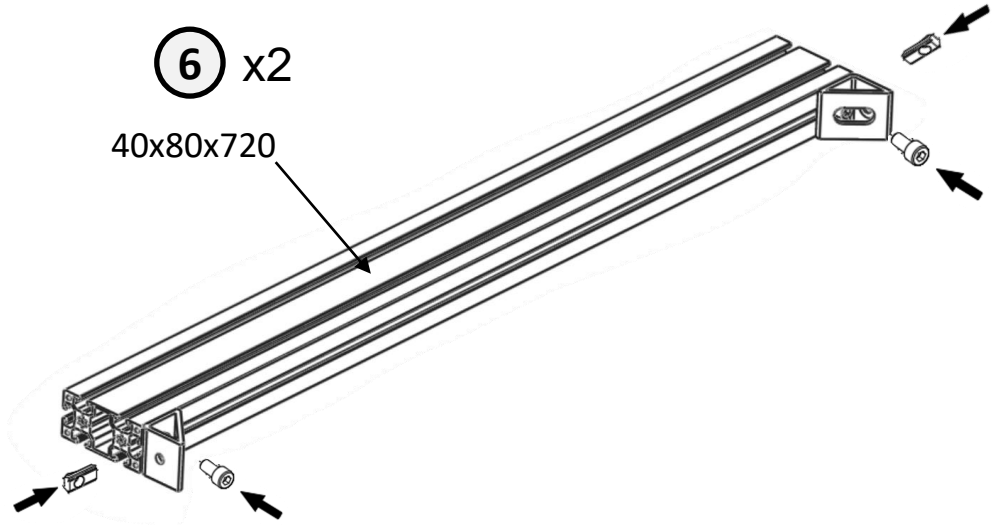

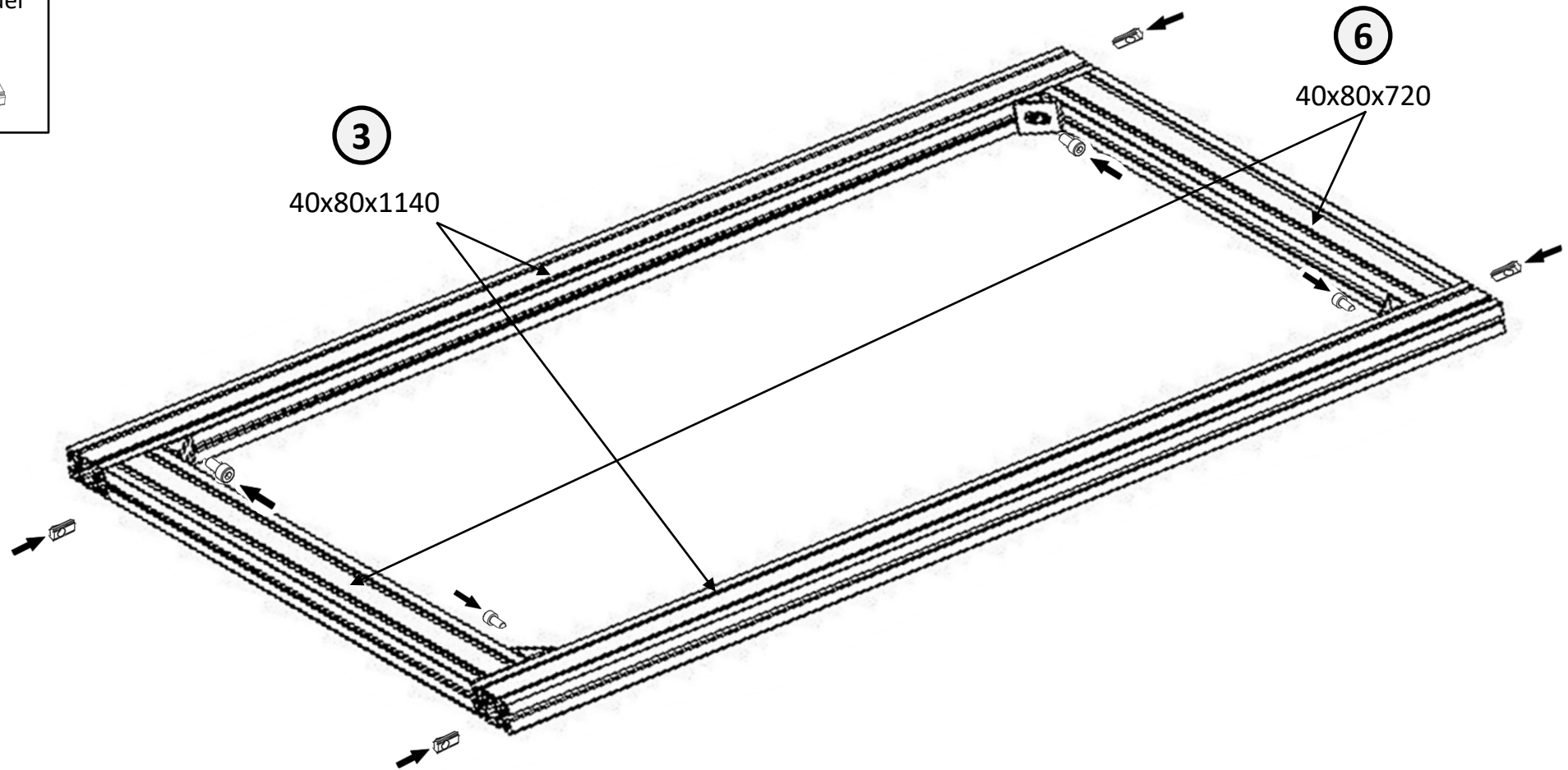
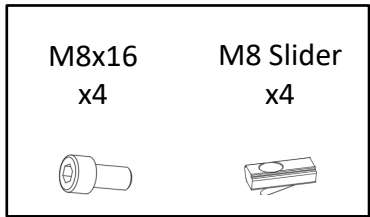

M8x16  
x32



M8 Slider  
x32



Flat  
x32



Spring M8  
x32

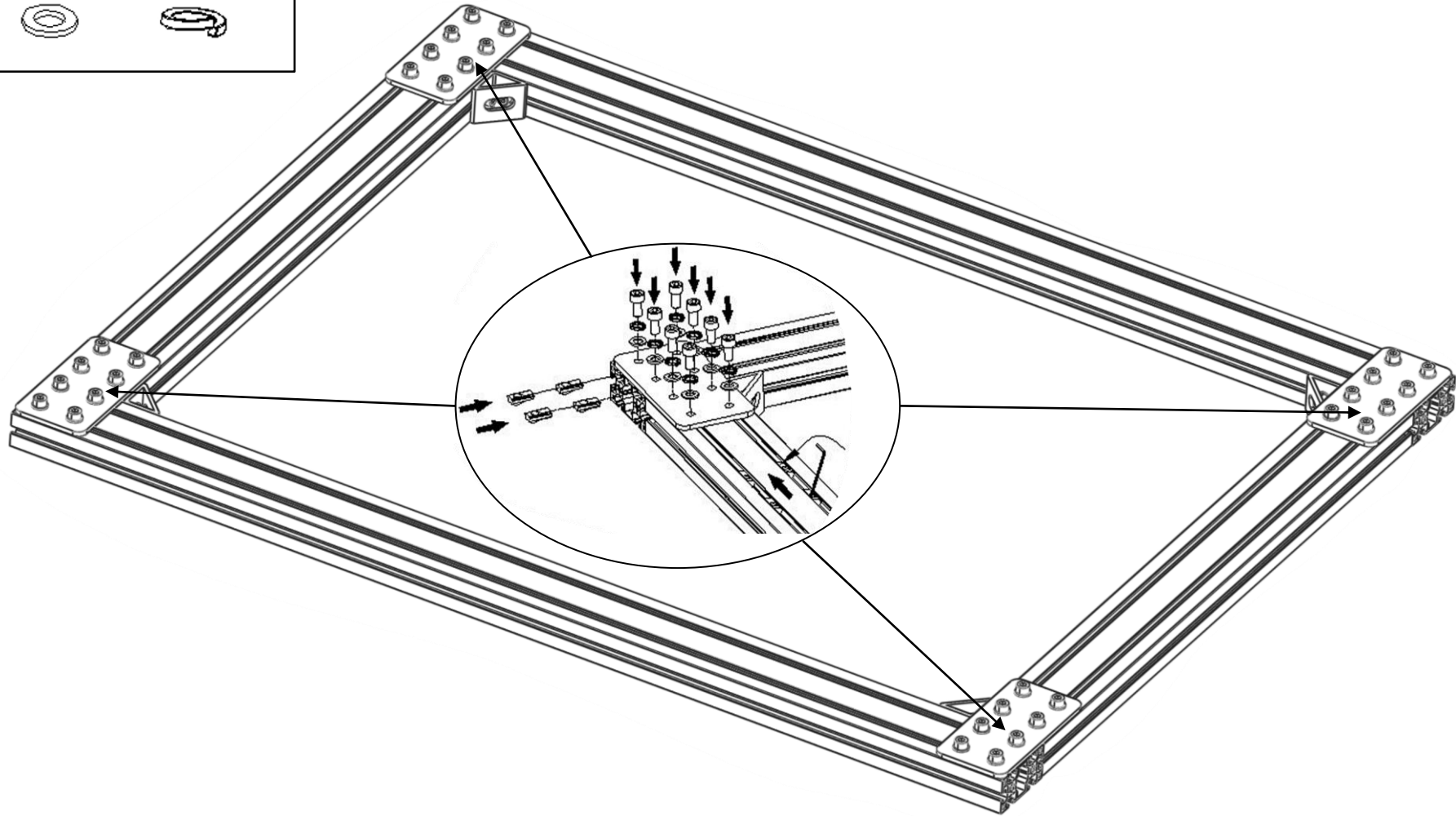

M8x16  
x16



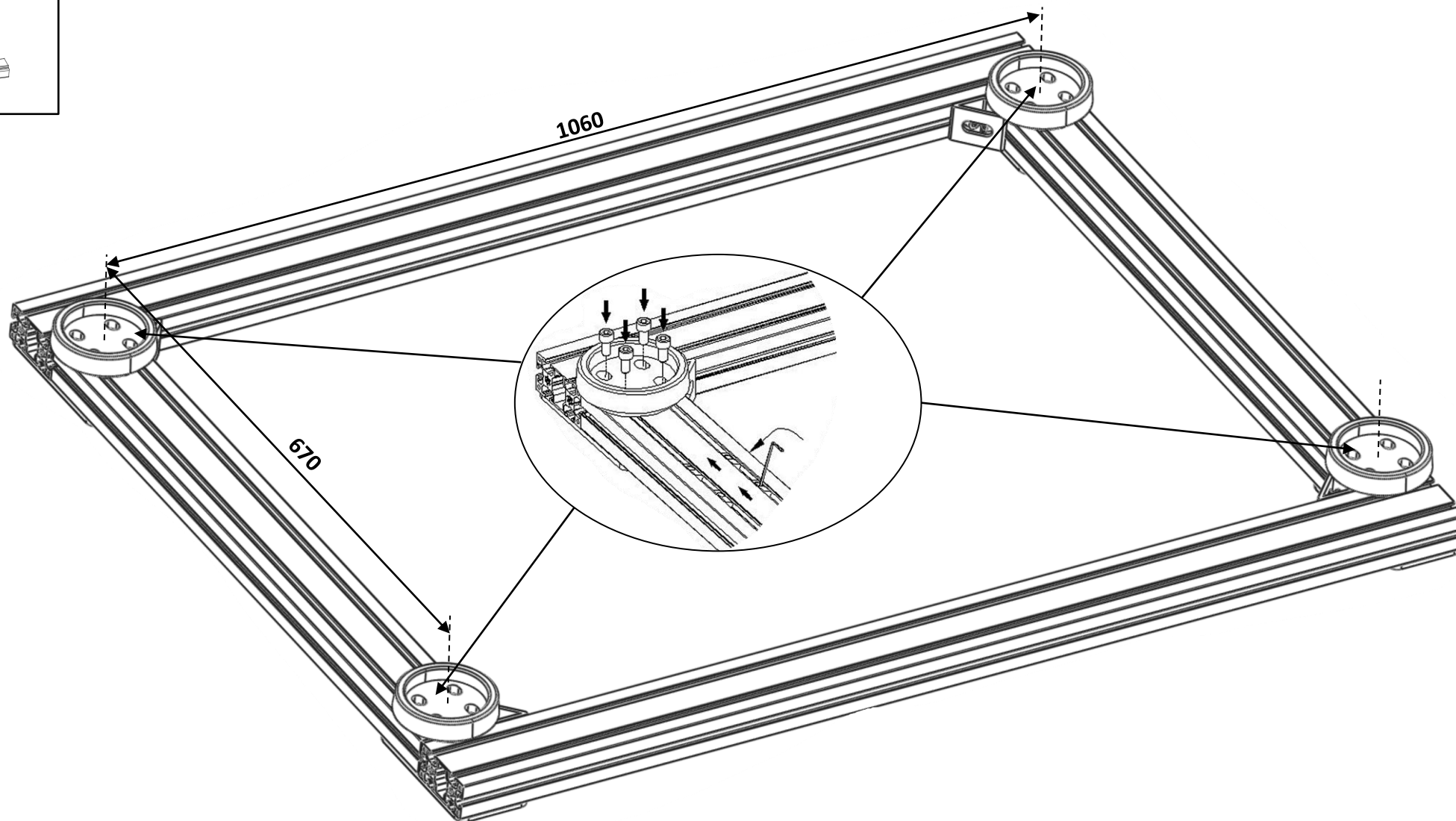

M8 Slider  
x16



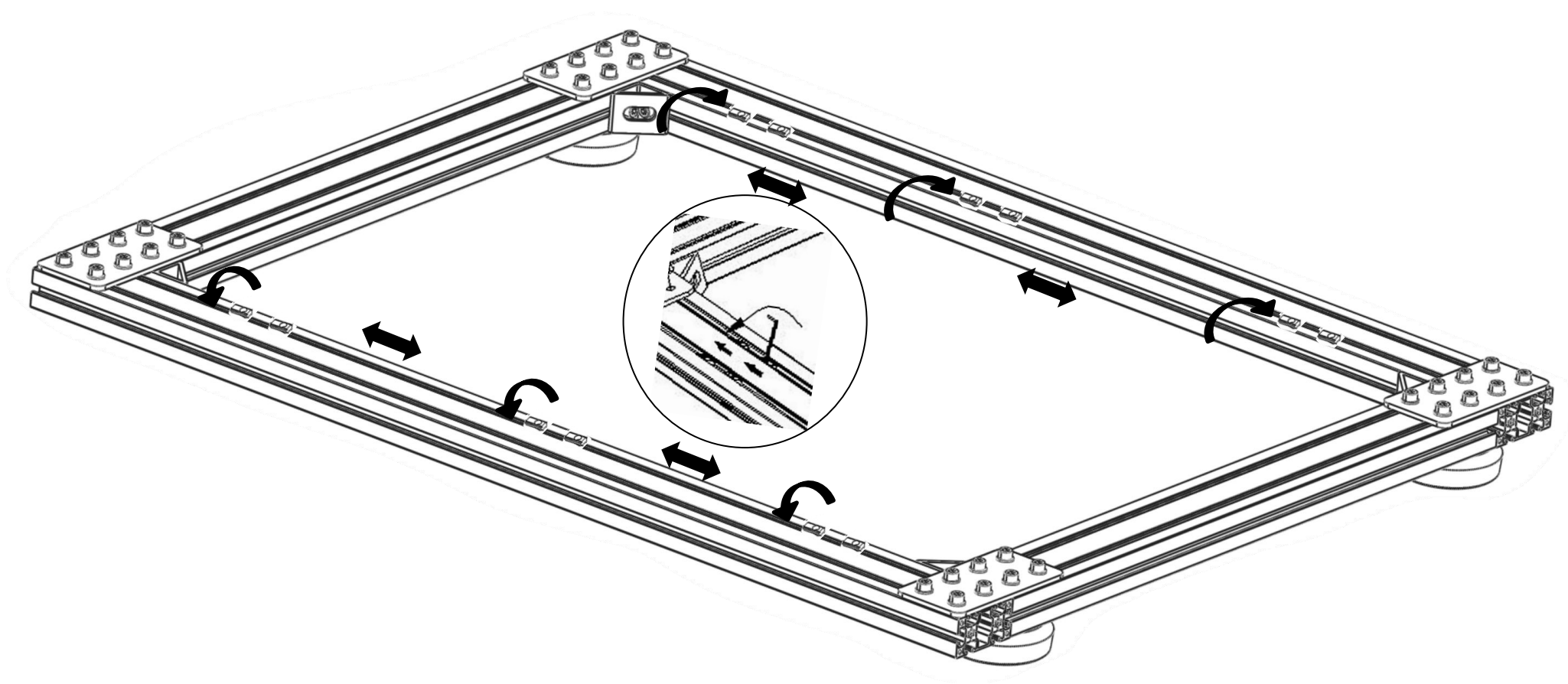

M8 Slider  
x12



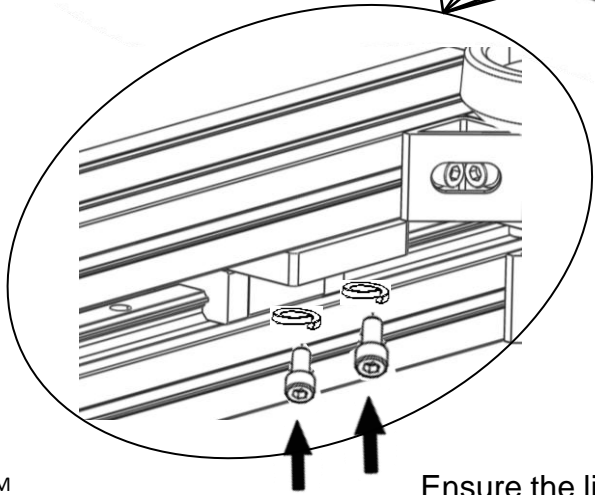
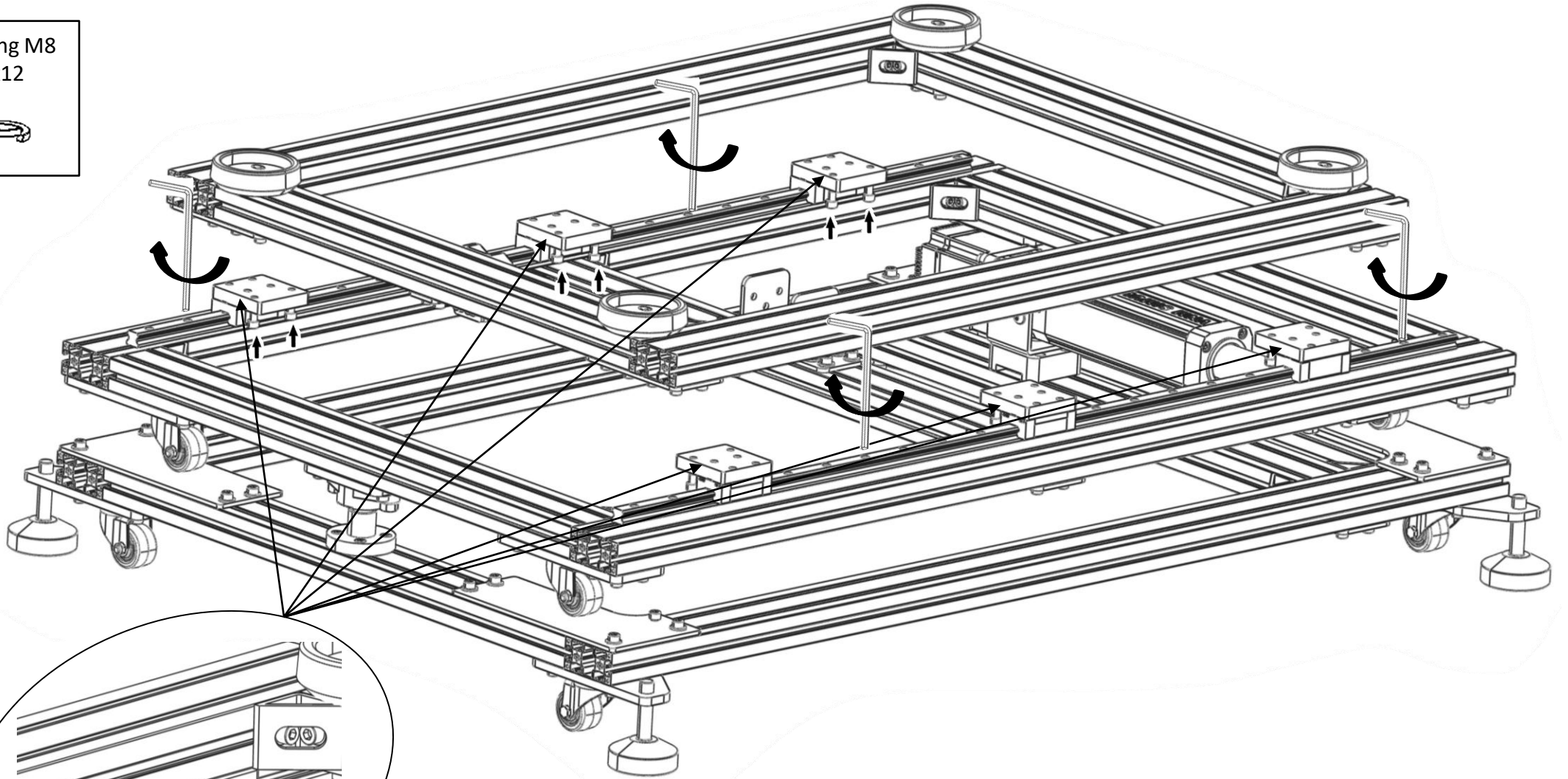



M8x16 x12	Spring M8 x12
	

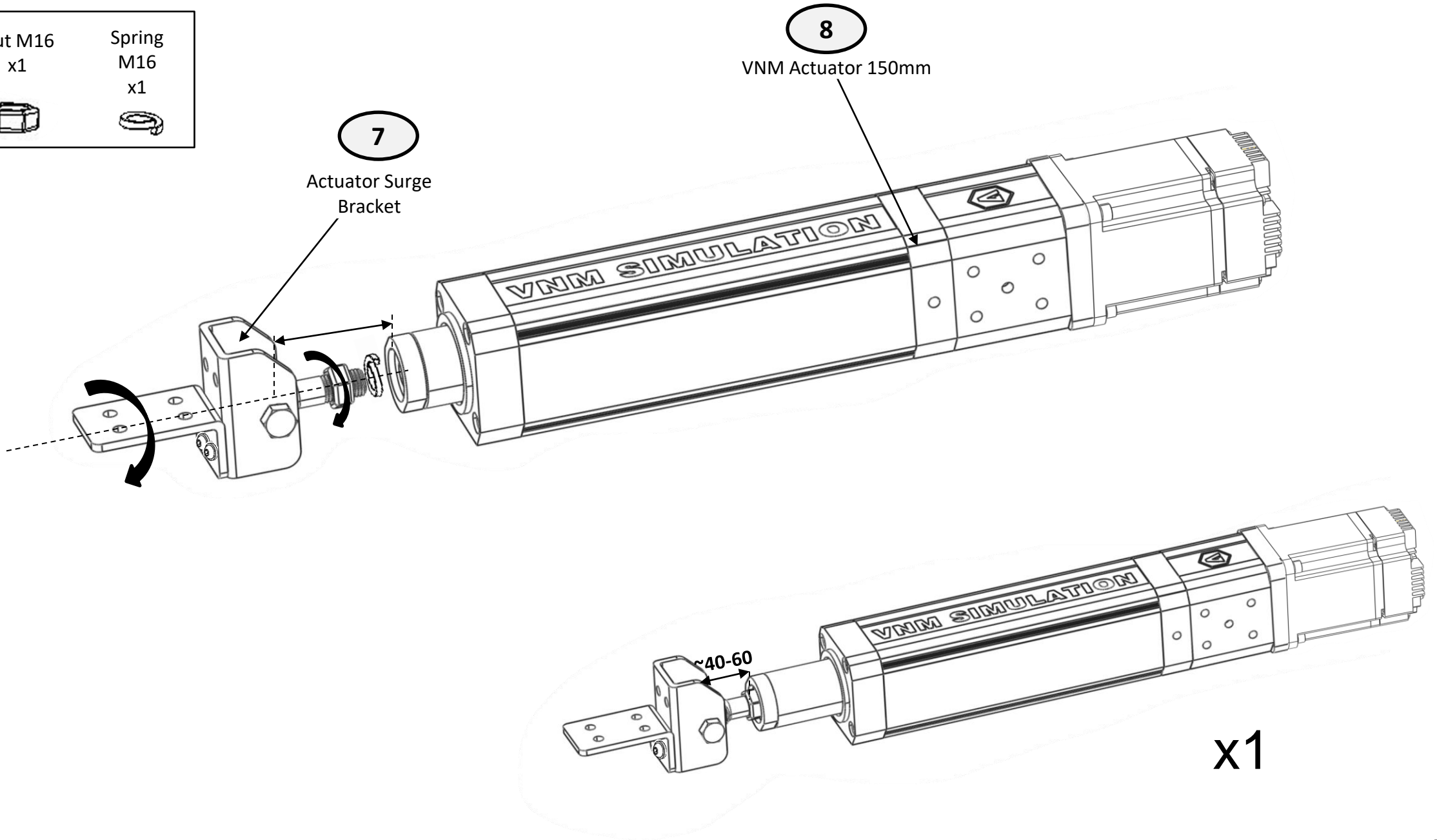

Ensure the linear rail and carriage **move smoothly**, then securely tighten all screws at this stage (M6x16 & M8x16).

Nut M16 x1	Spring M16 x1
	



M8x16 x6	Flat x6	Spring M8 x6	M8 Slider x6
			

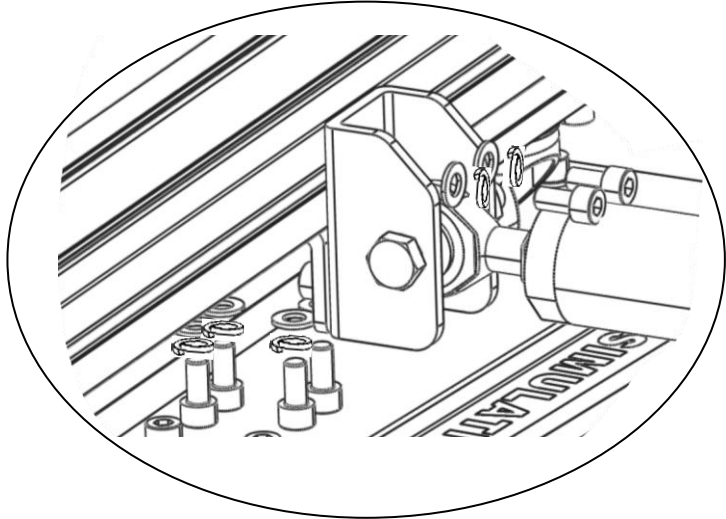
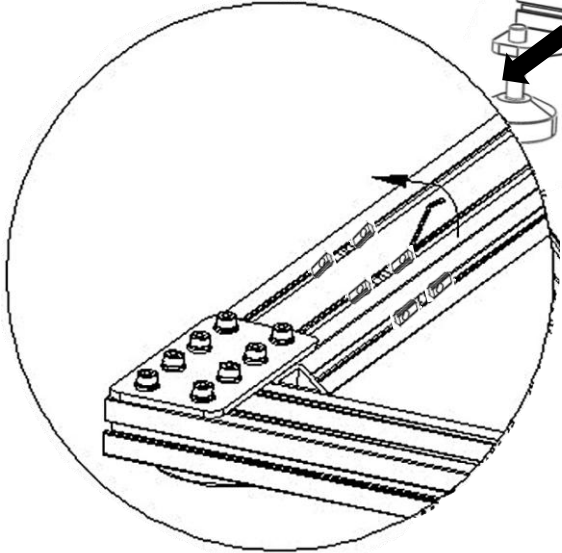
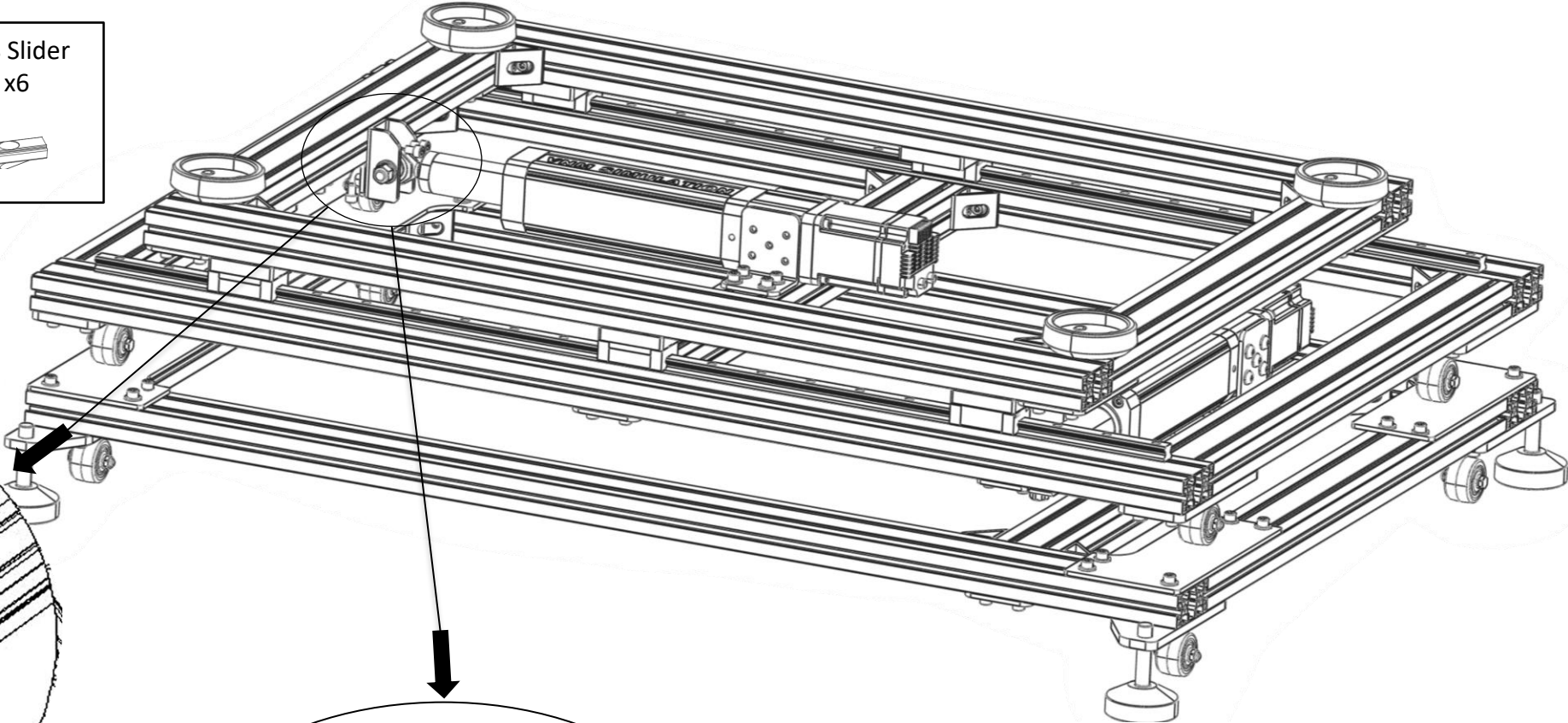

Spring M8  
x10



Mo M8x16  
x10



Flat  
x10

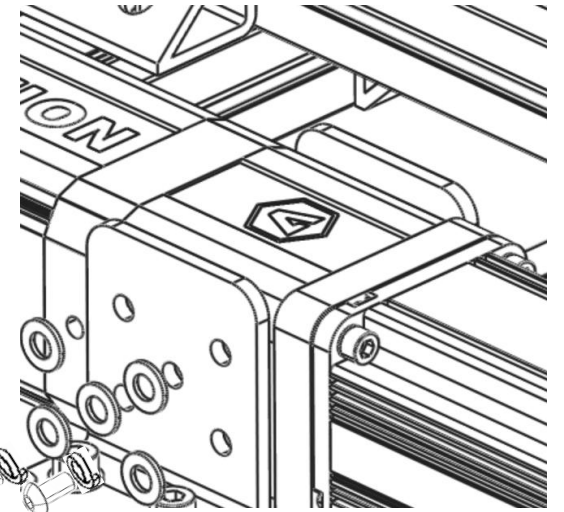
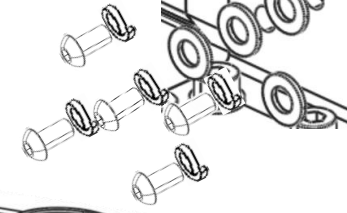
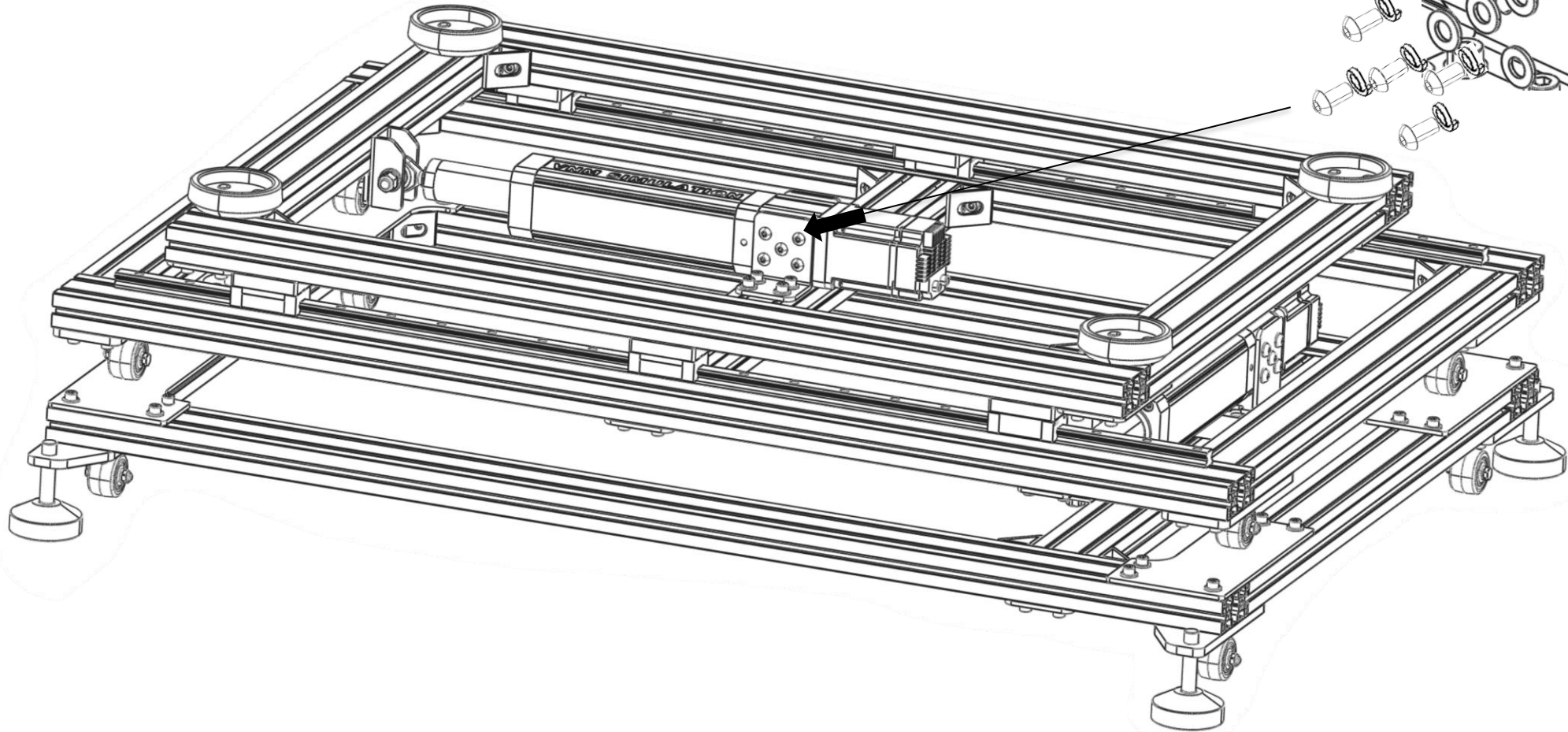



**20**  
Alu Cover

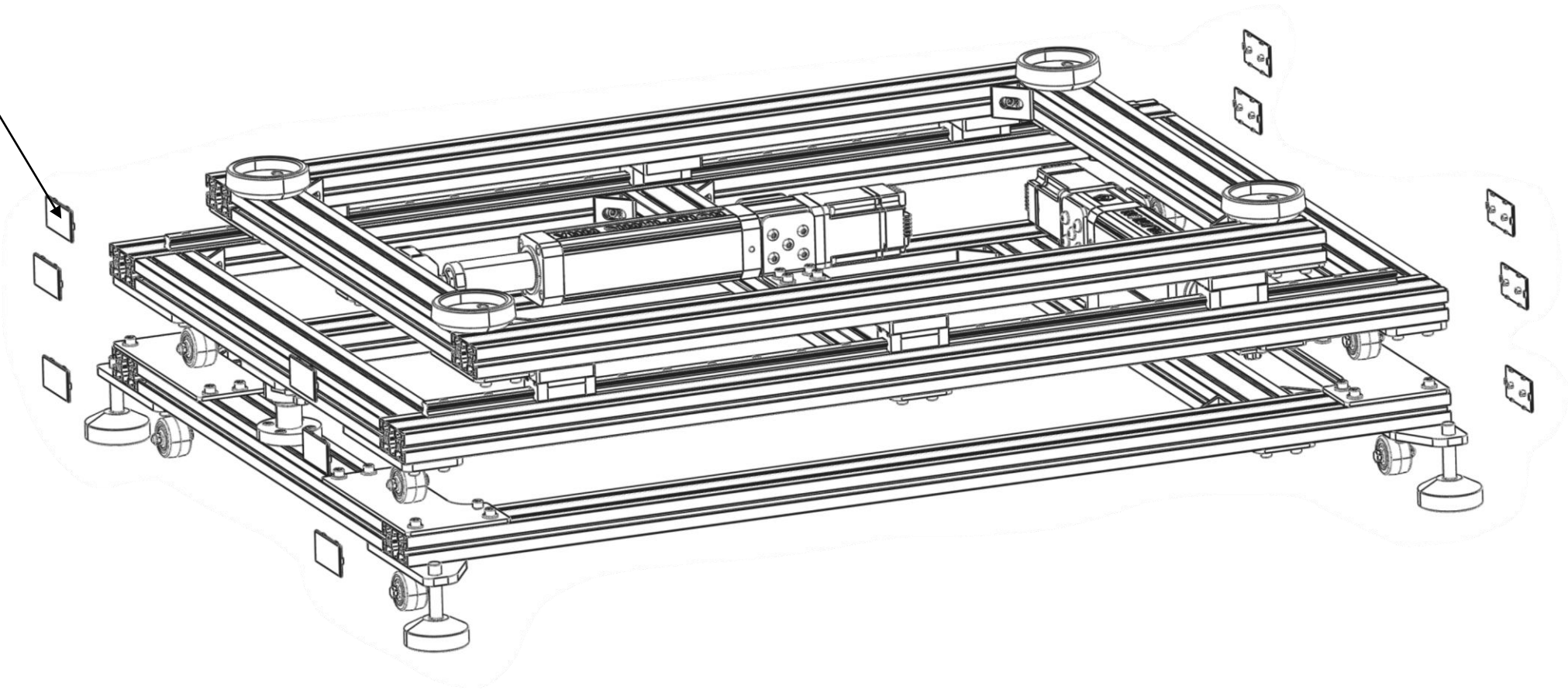

# Installation guide VNM Surge & TL Platform

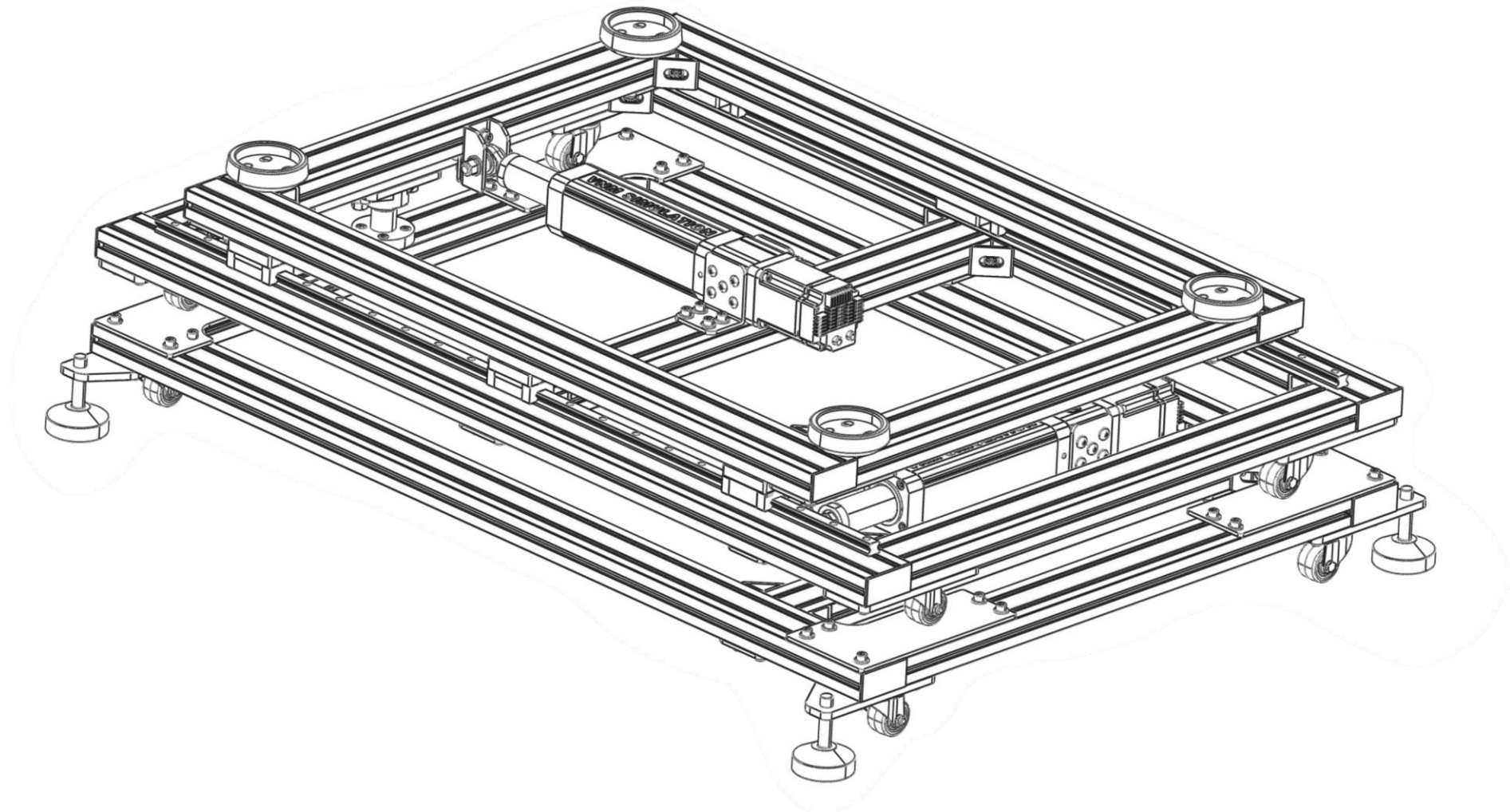

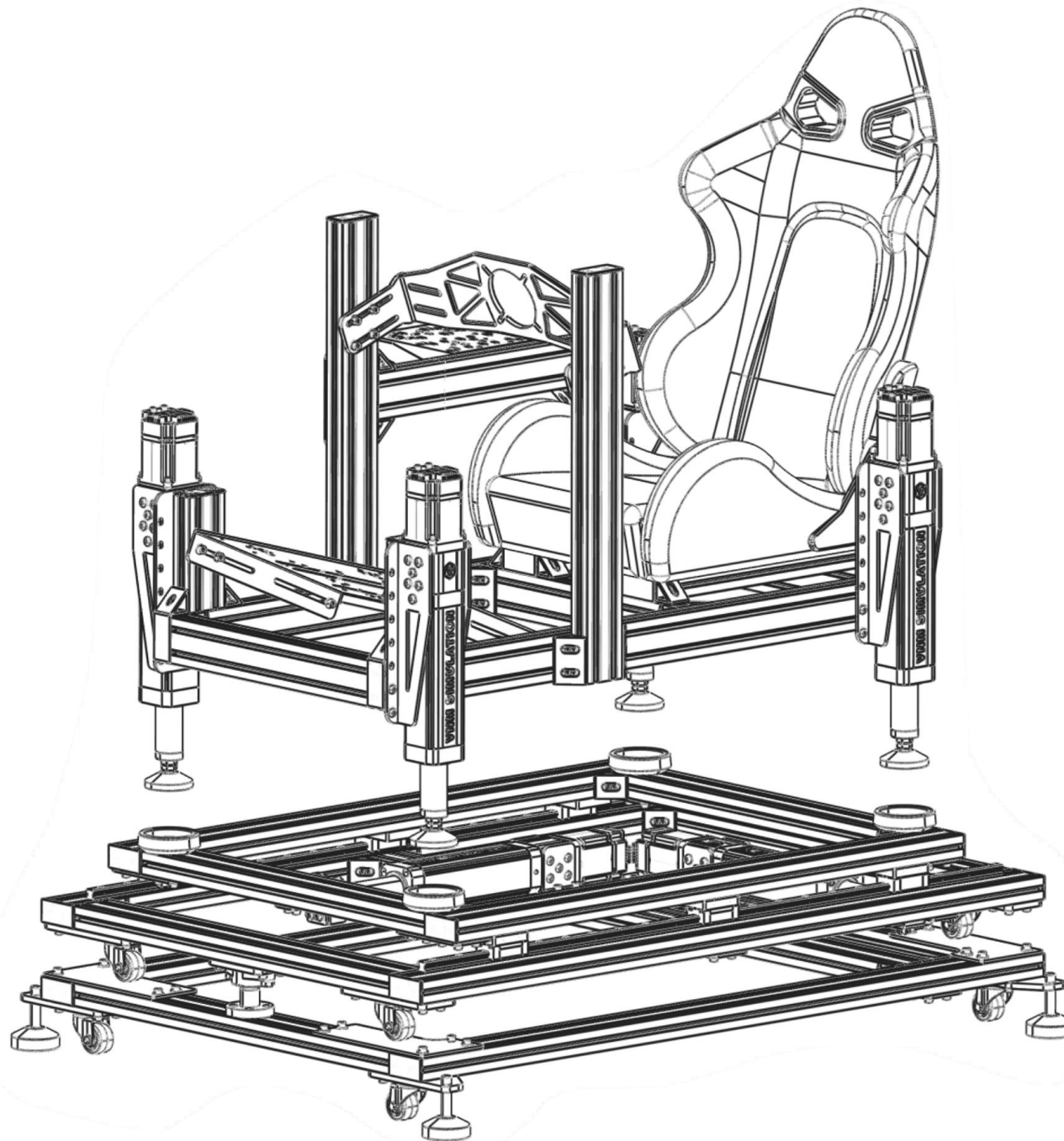

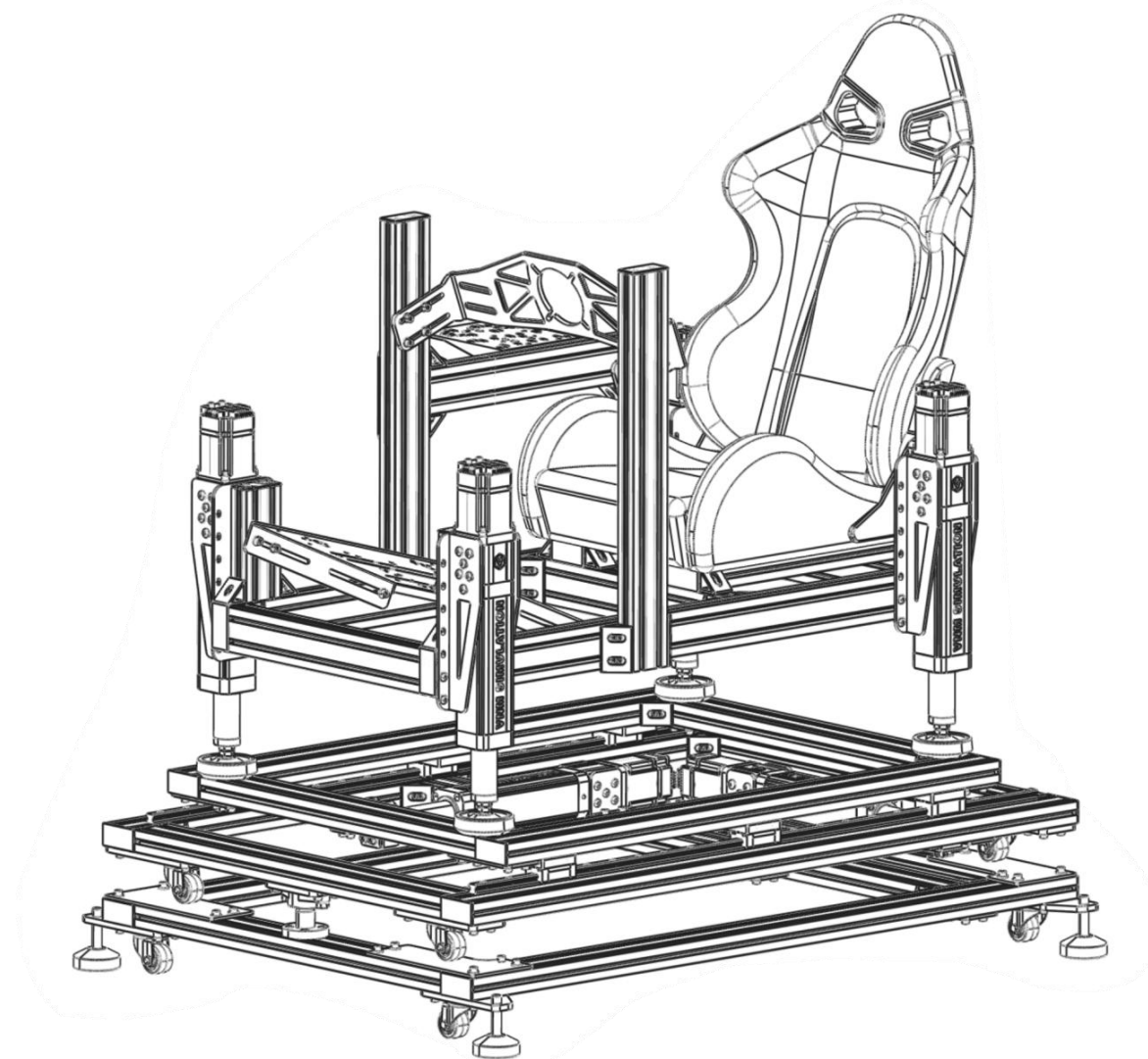

*“Congratulations on completing your rig assembly.  
If you have any questions or encounter any problems, please contact us for support!”*