

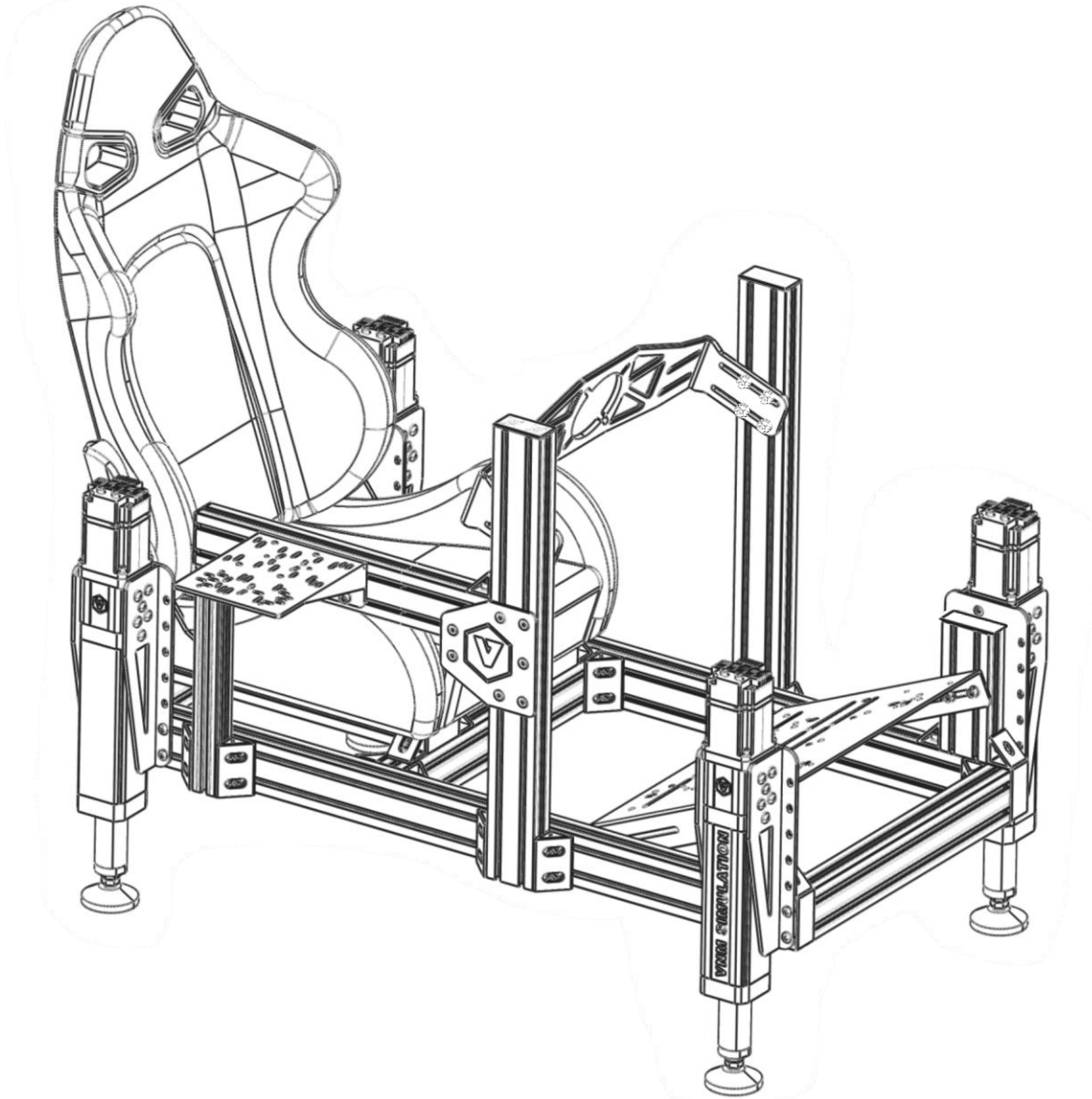

Installation guide

VNM Rig 3Dof 4Actuators



① 40x80x1200
x2

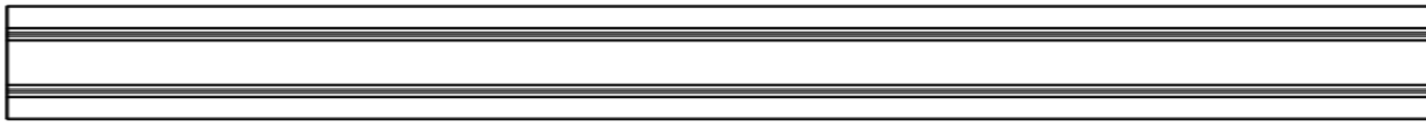

② 40x80x720
x2

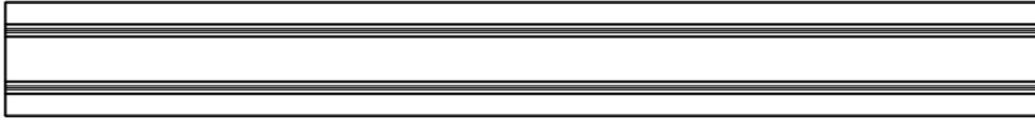

③ 40x80x500
x6

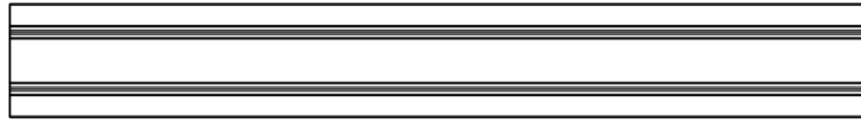

④ 40x40x350
x1

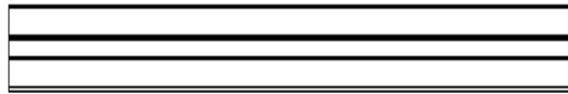

⑤ 40x80x200
x2



⑥ VNM Actuator
(with U bracket)
x4

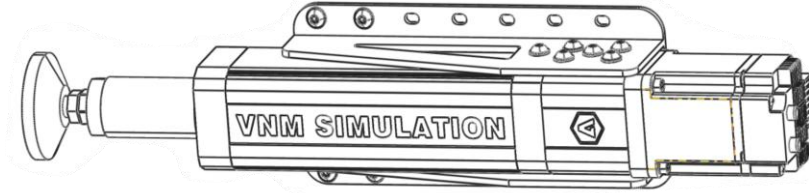

⑦ VNM Plate
x1

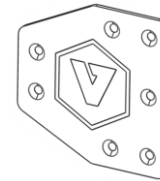

⑧ Handbrake
Shifter Bracket
x1

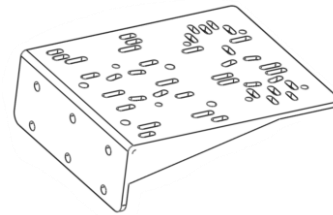

⑨ Pedal base plate V3
x1

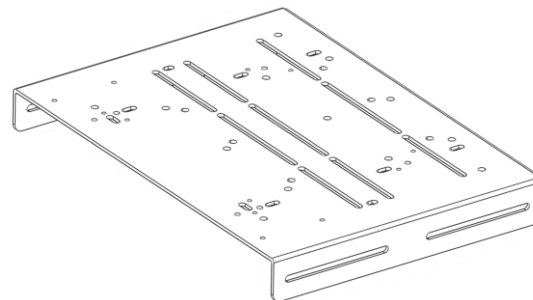

⑩ Wheel base mount V1
x1

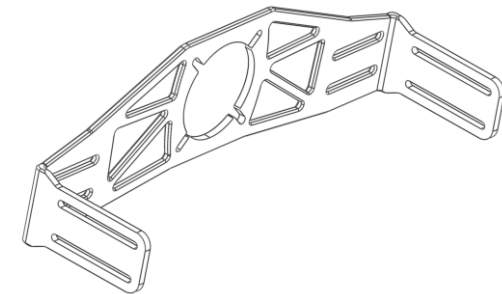

11

Driver's Seat
(May not include)
x1

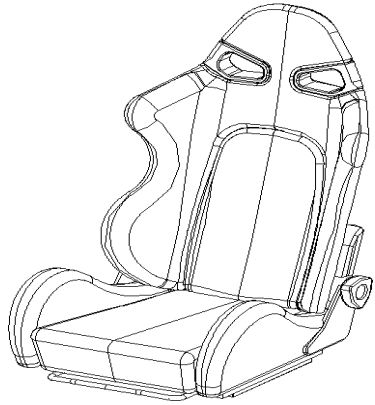

Flat, Spring M8
x86



M8x20
x8

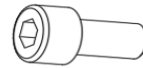

M8x16
x120

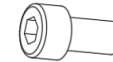

M8 Slider
x135

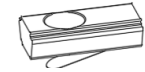

M16 Nuts, Spring M16
x4



M8x16
x7

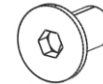

M8x16
x48



12

Actuator Feet
x4

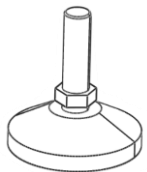

4080 Conner Alu
x14

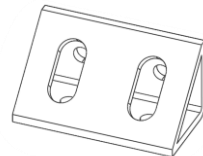

4040 Conner Alu
x15



Alu Cover
x13

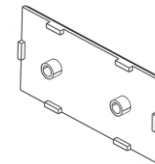

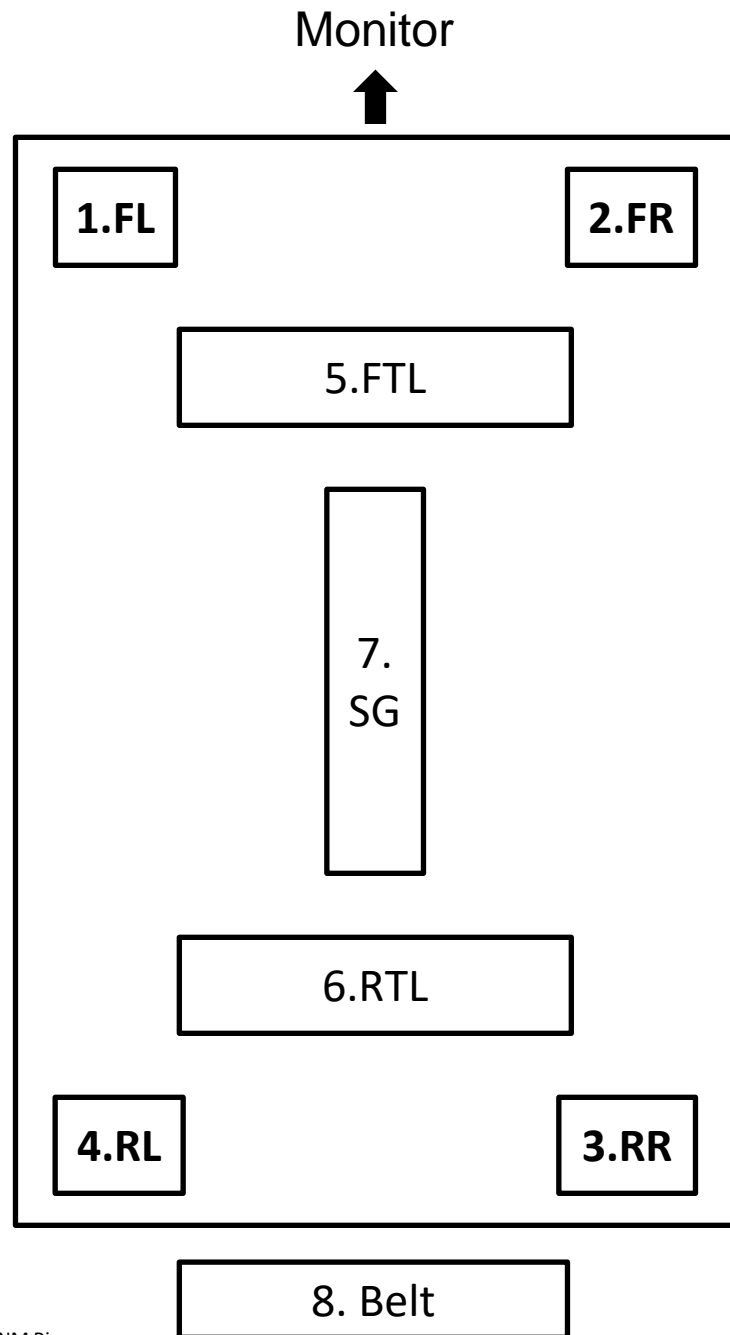

Disclaimer : Before installing or configuring the motion system on your rig, ensure that the surrounding area is completely clear. This helps prevent collisions if the rig moves unexpectedly. Keep the motion rig away from nearby objects such as computer monitors, TVs, mobile phones, etc.

Method 1

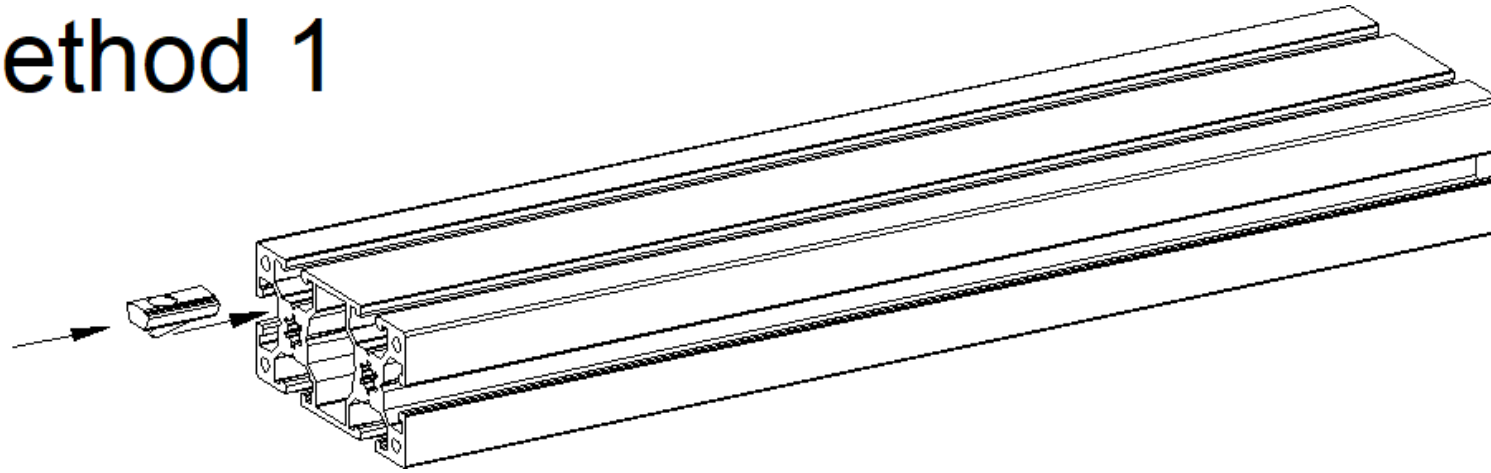

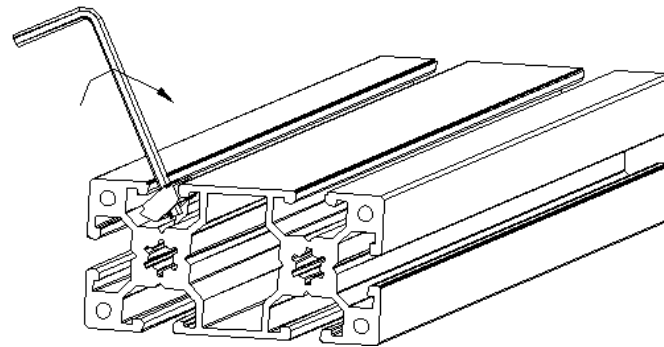

Method 2

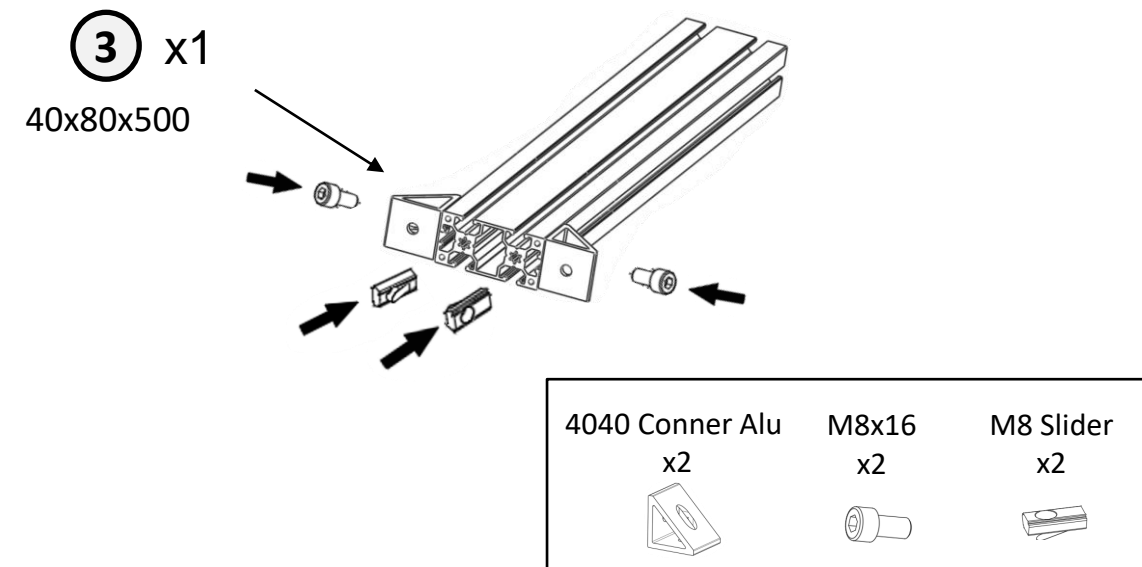
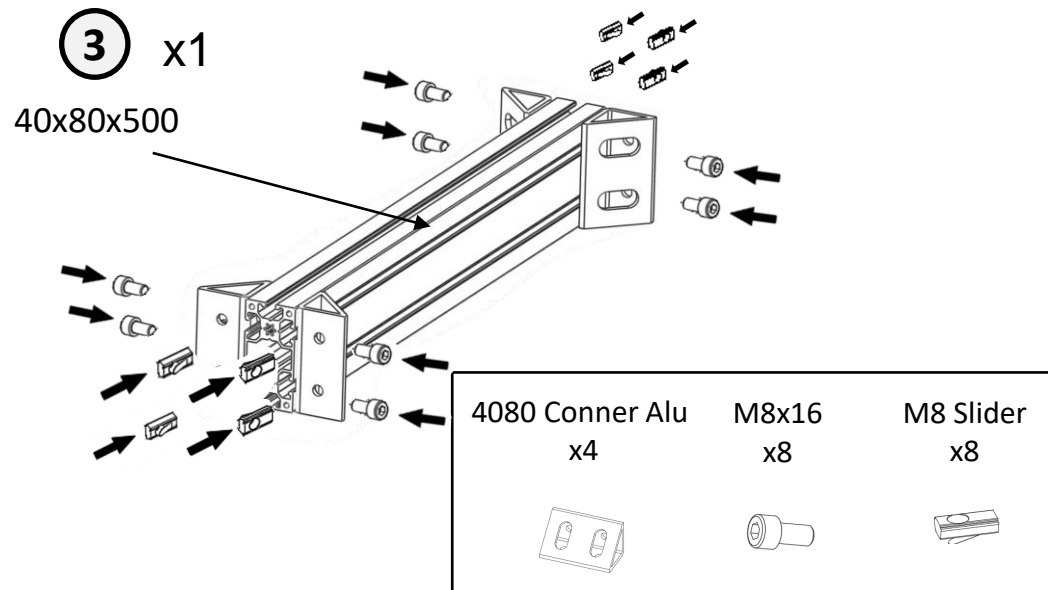
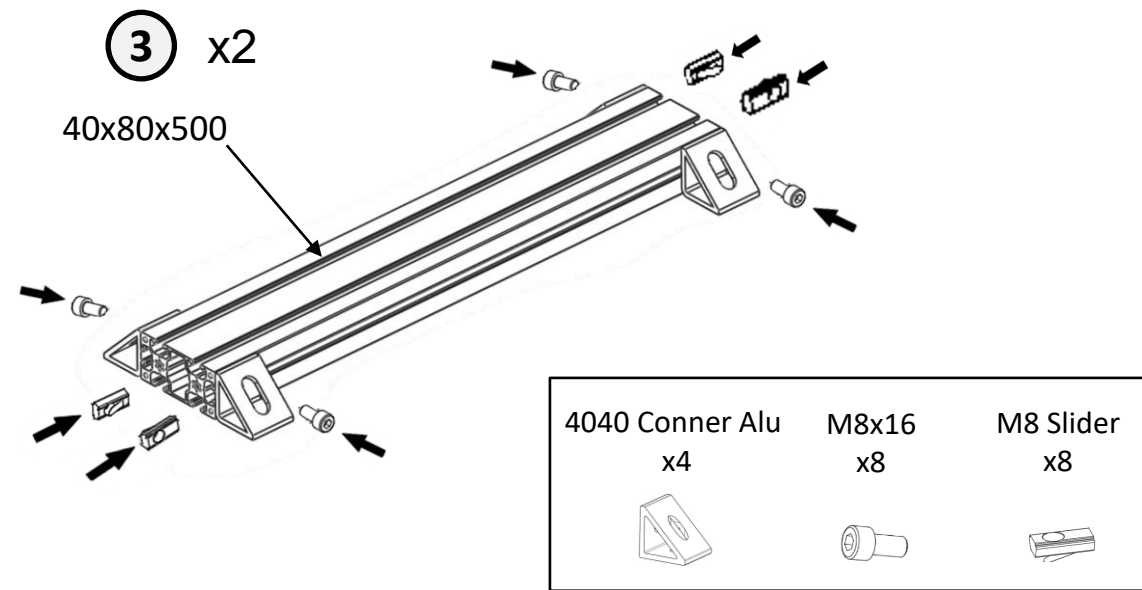
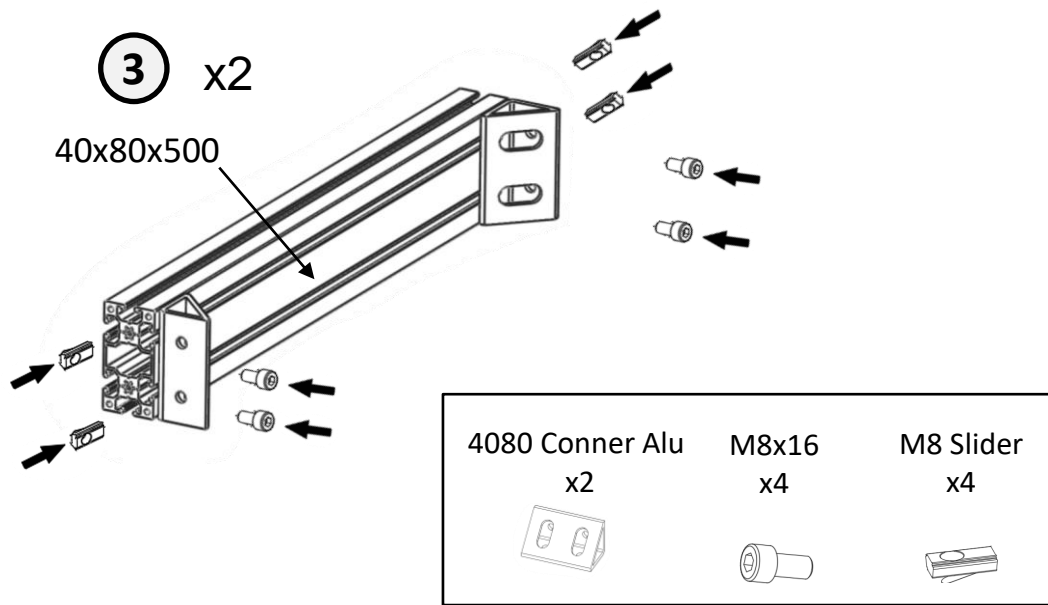

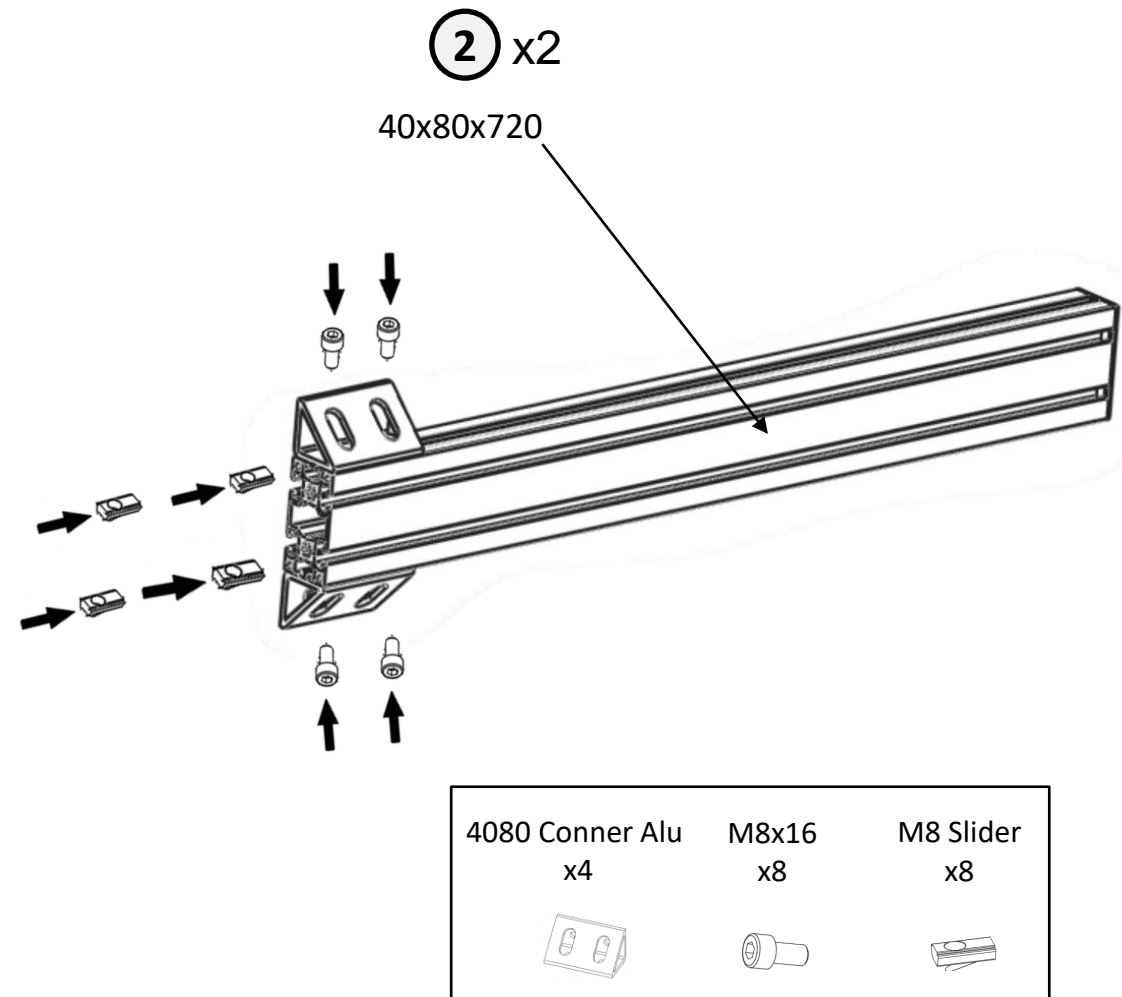
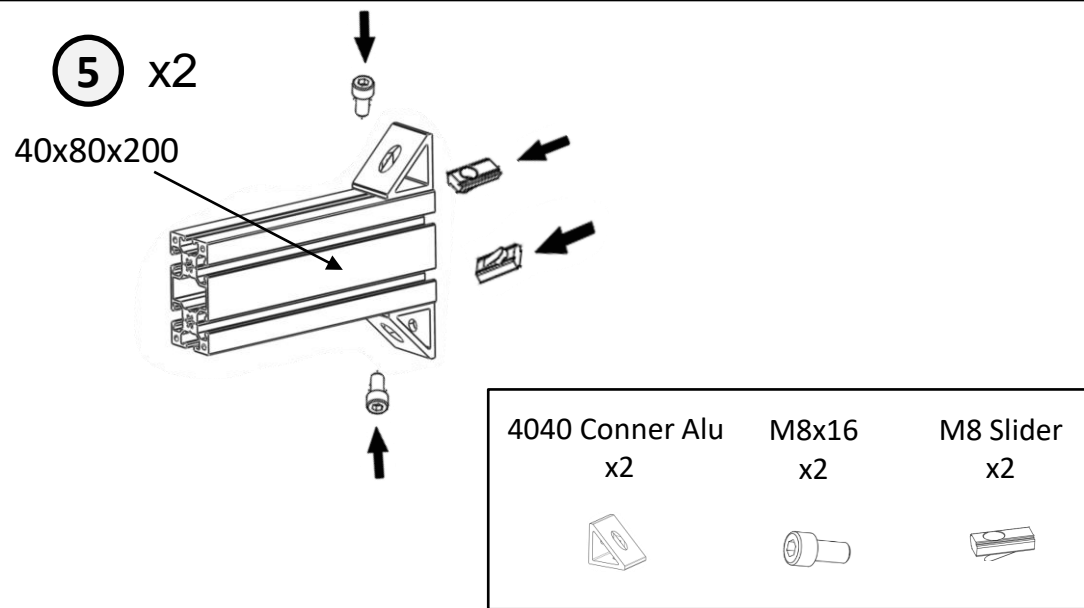
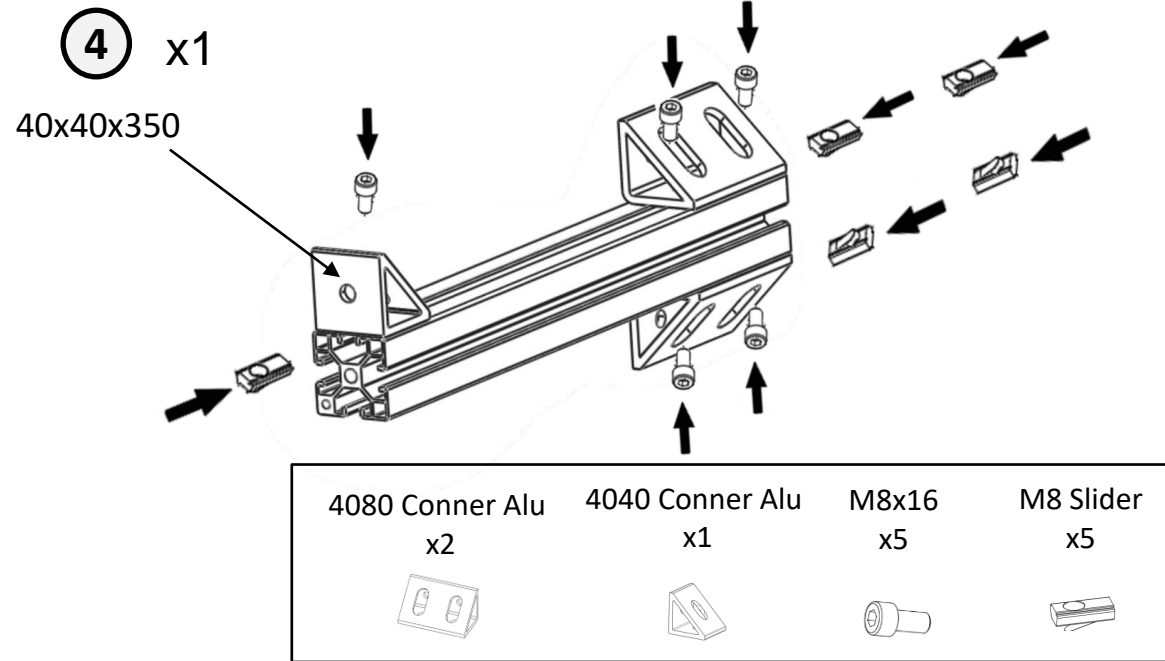





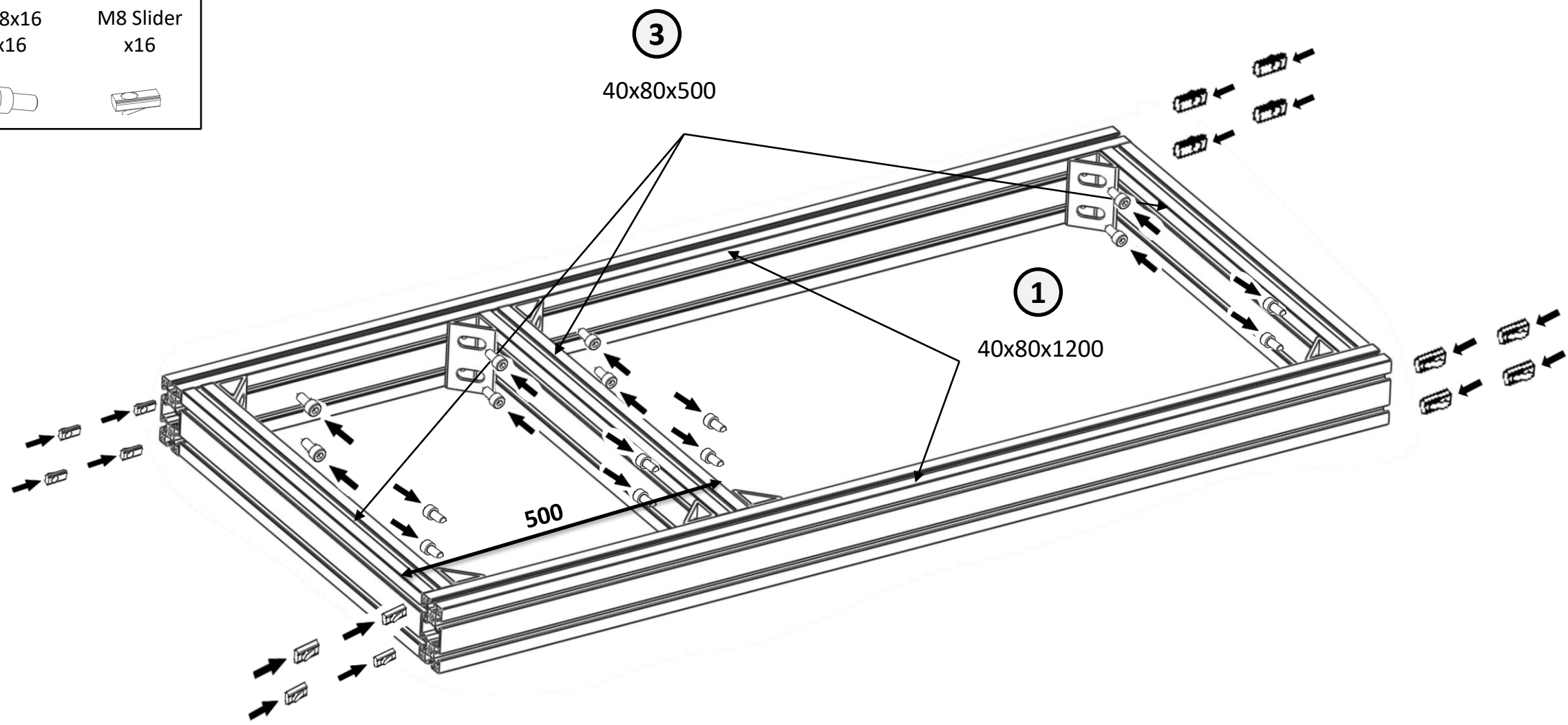

M8x16 x16	M8 Slider x16
	



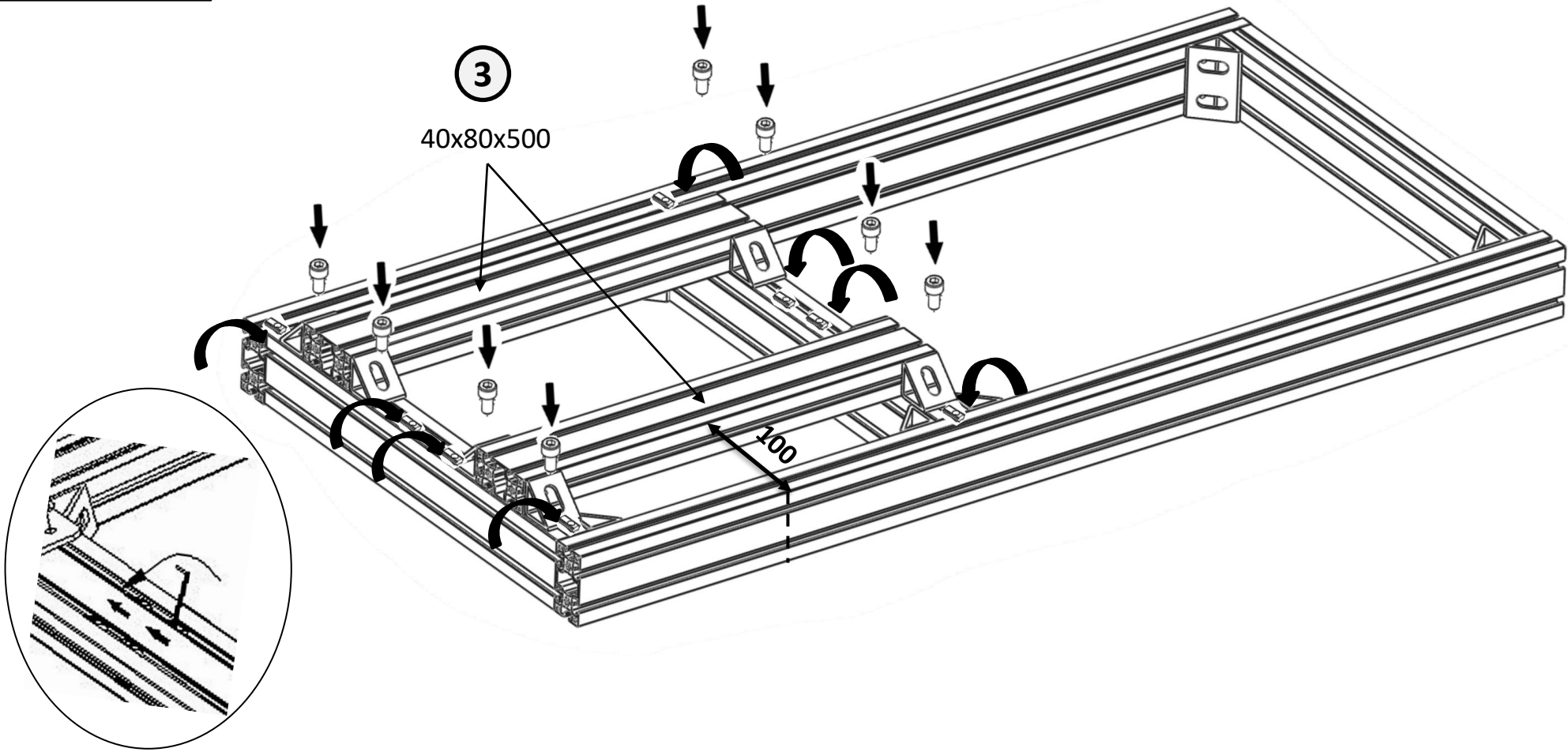

M8x16 x8	M8 Slider x8
	



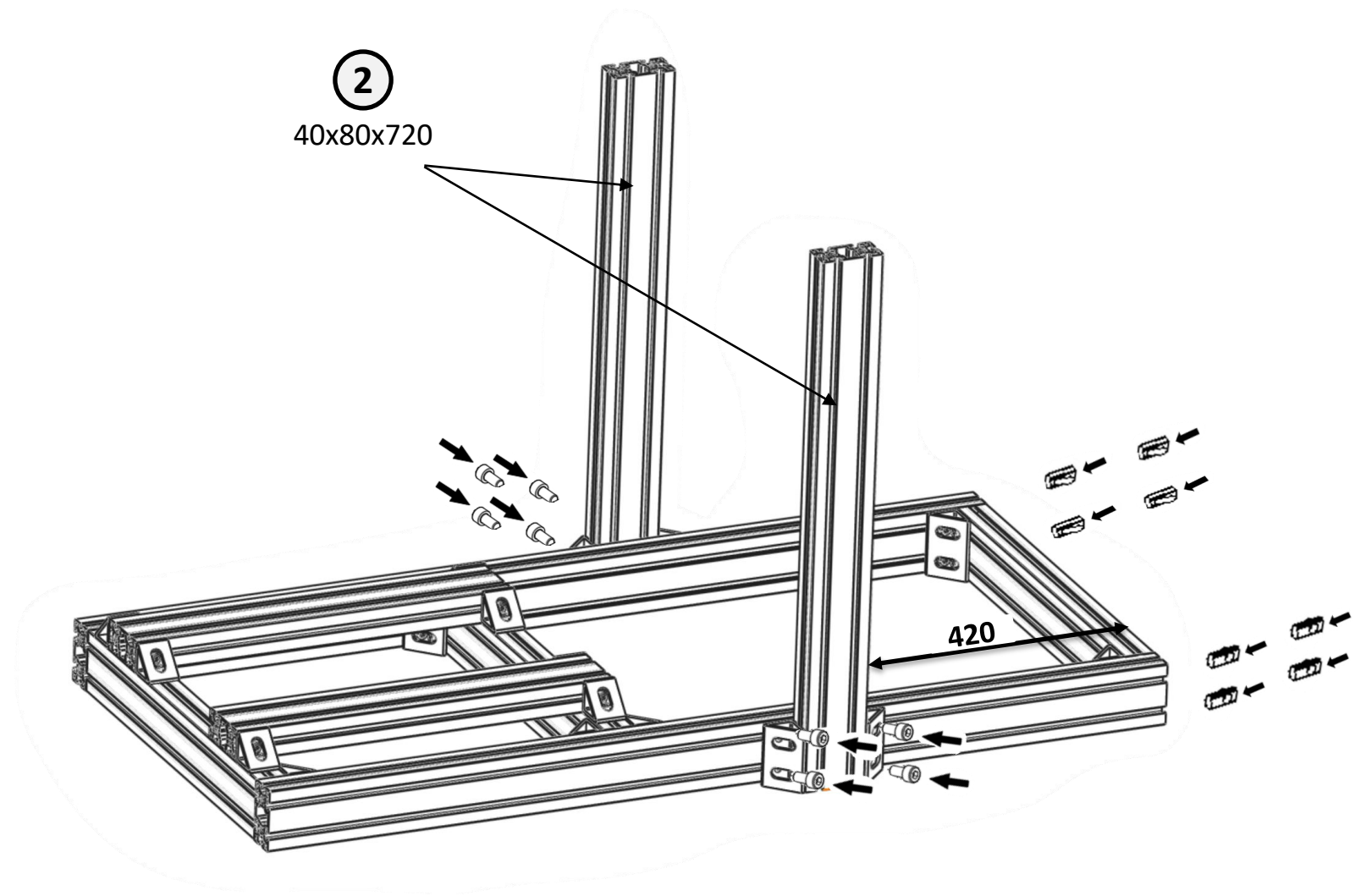

M8x16 x8	M8 Slider x8
	



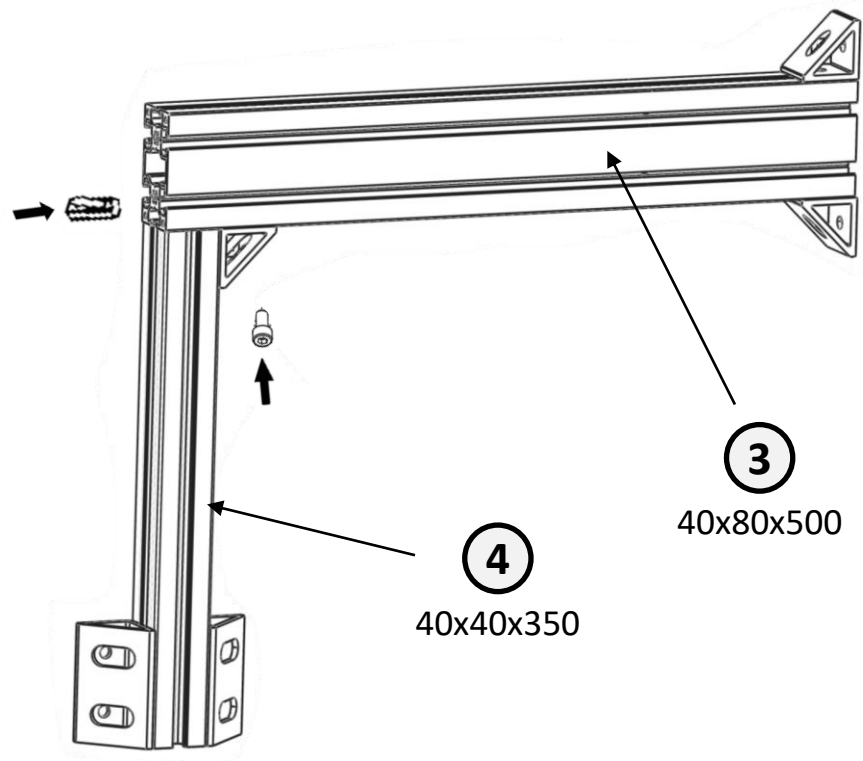

M8x16 x1	M8 Slider x1
	



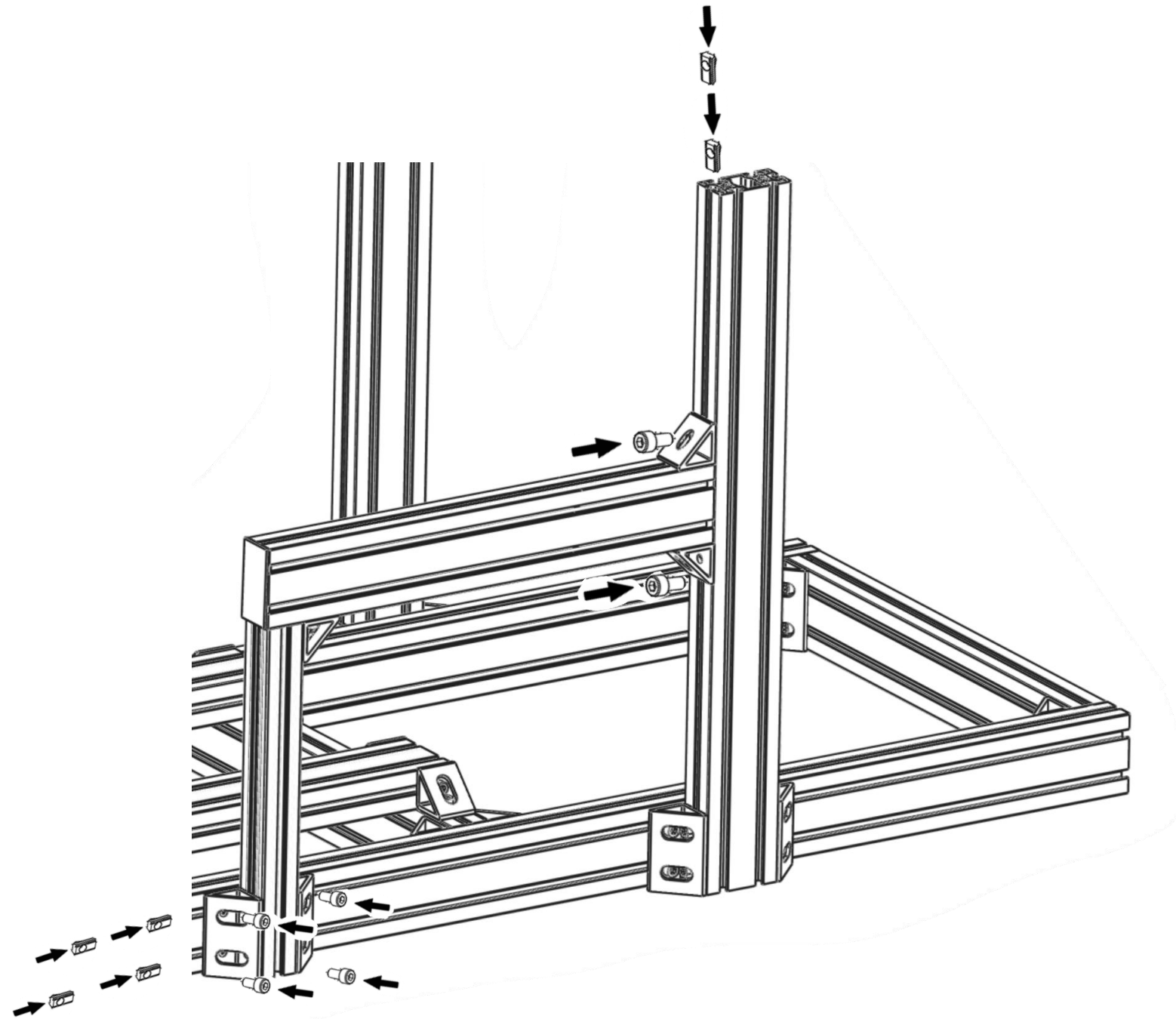

M8x16 x6	M8 Slider x6
	

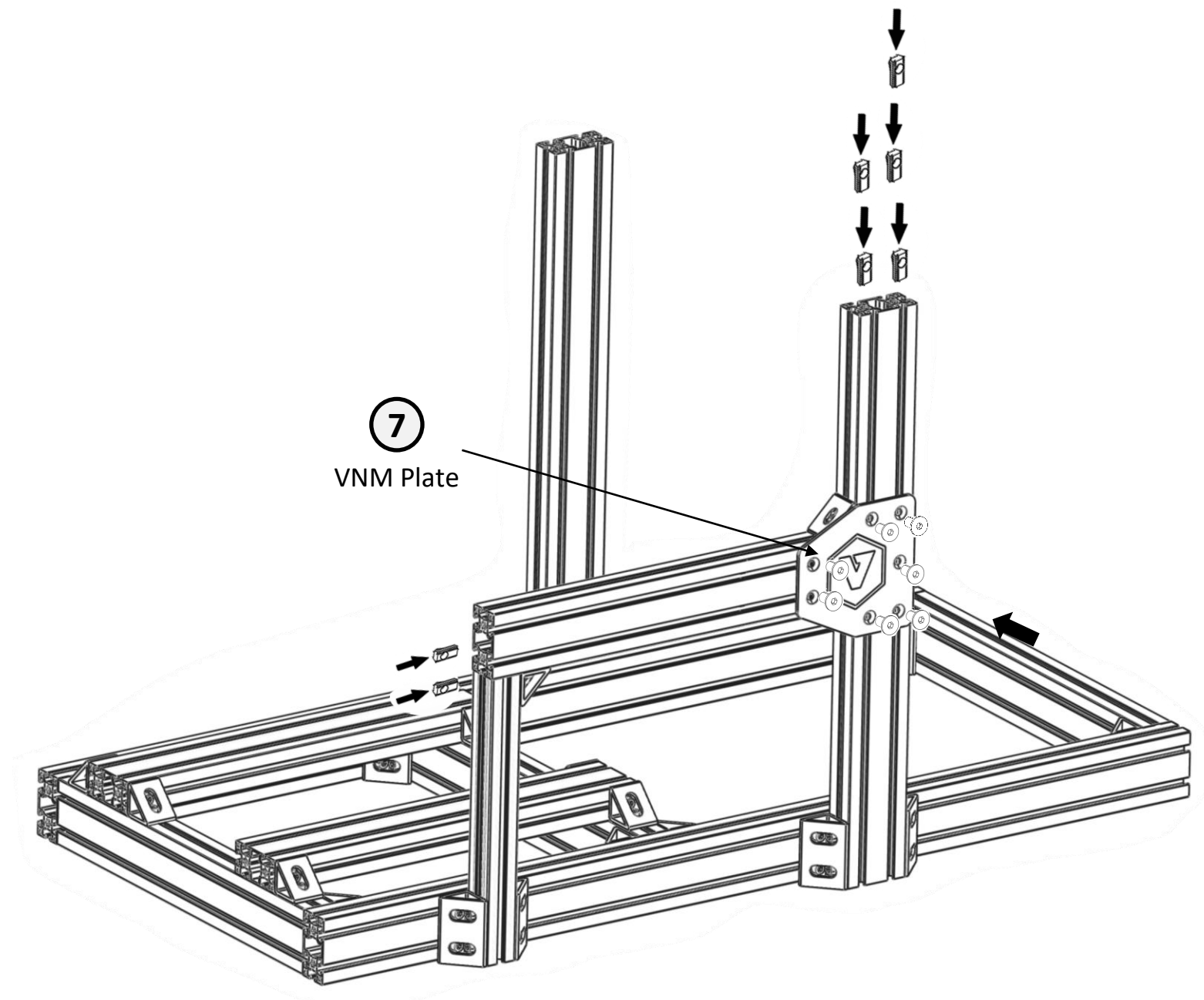

M8x16 x7	M8 Slider x7
	





M8x16 x6	M8 Slider x6	Flat, Spring M8 x6
		

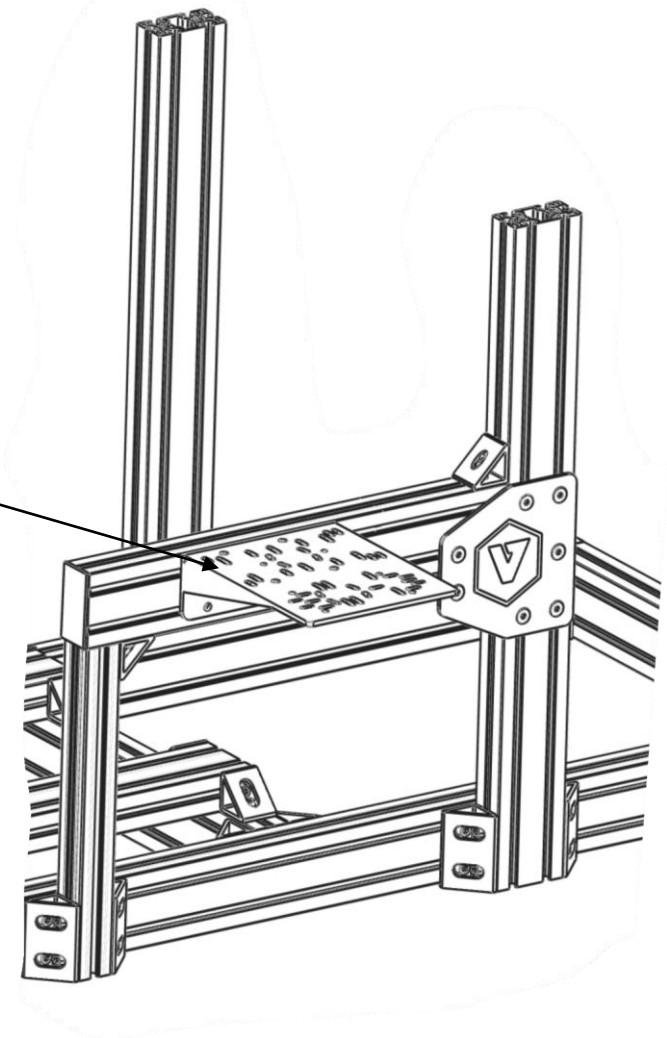
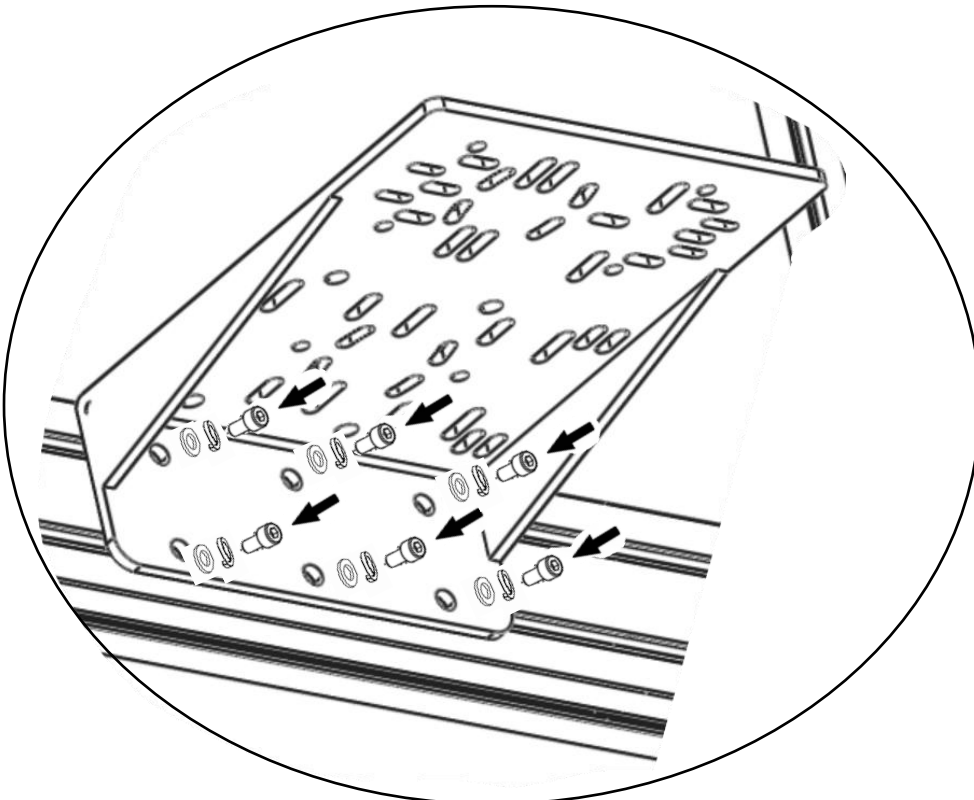

8

Handbrake Shifter
Bracket



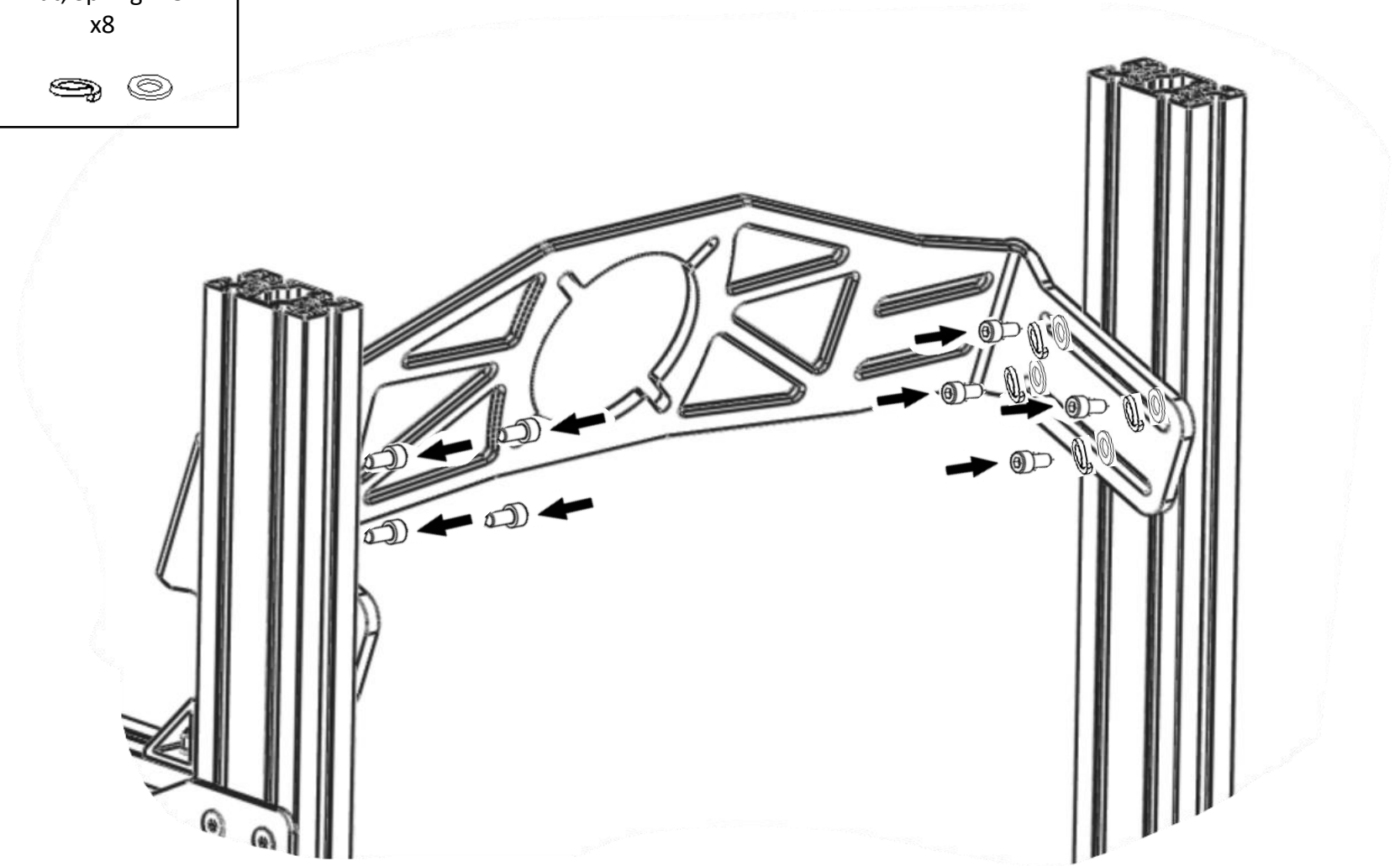

M8x20 x8	M8 Slider x8	Flat, Spring M8 x8
		

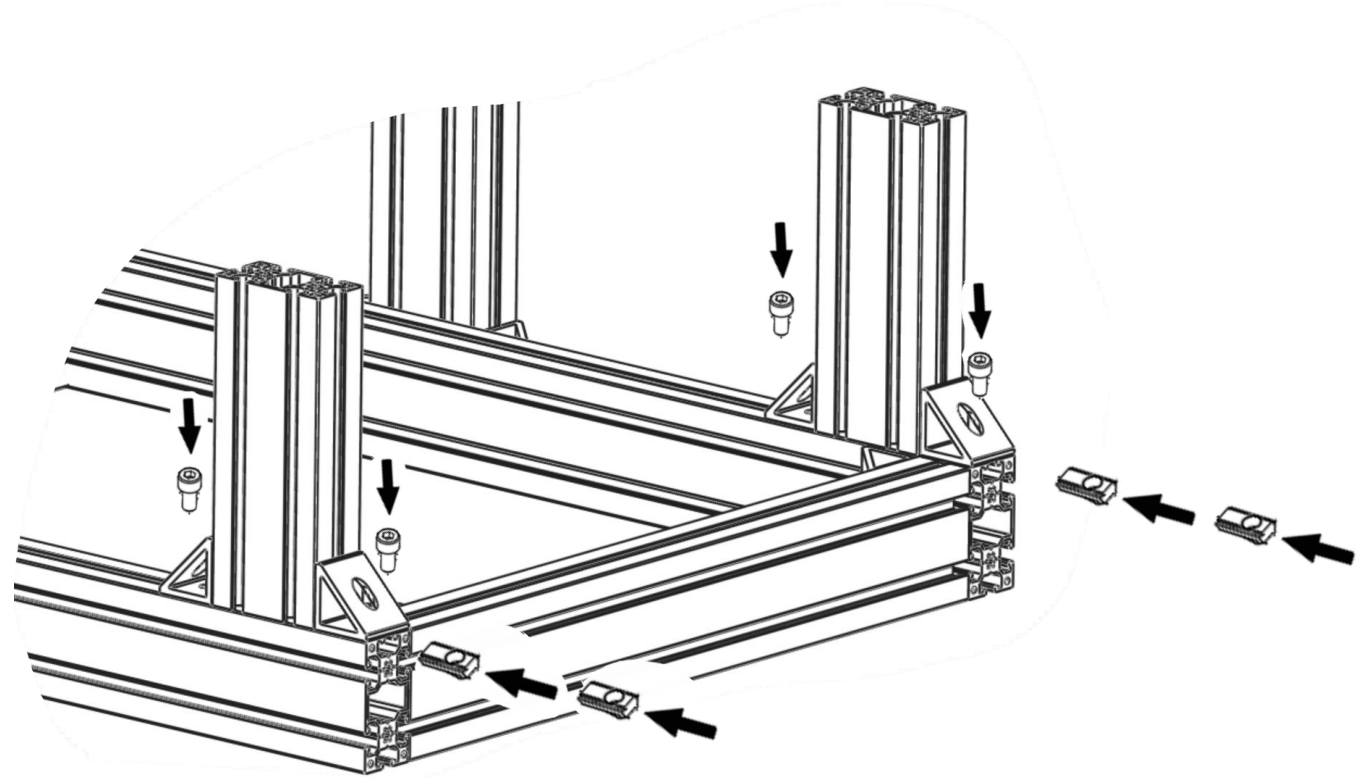

M8x16 x4	M8 Slider x4
	

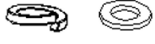

M8x16 x6	M8 Slider x6	Flat, Spring M8 x6
		

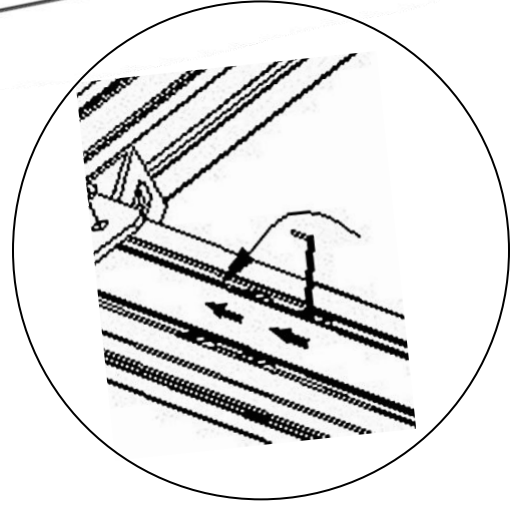
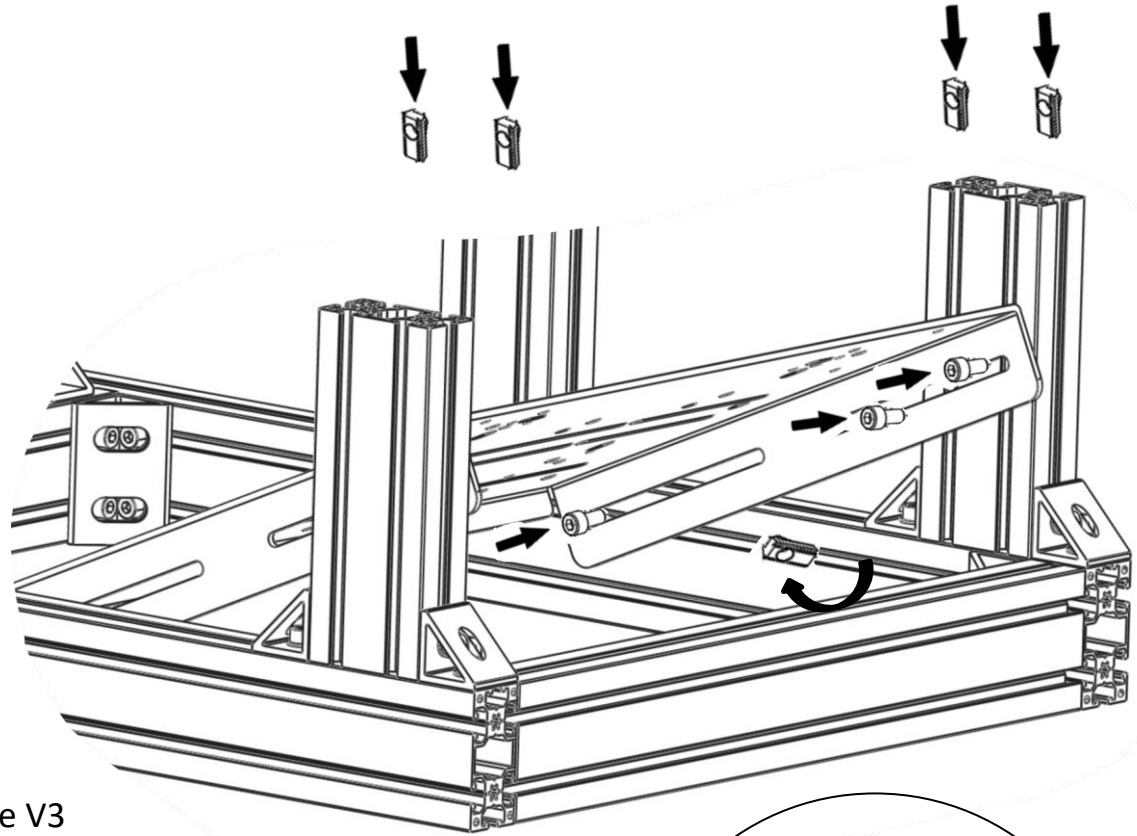



10

Wheel Base Mount
V1

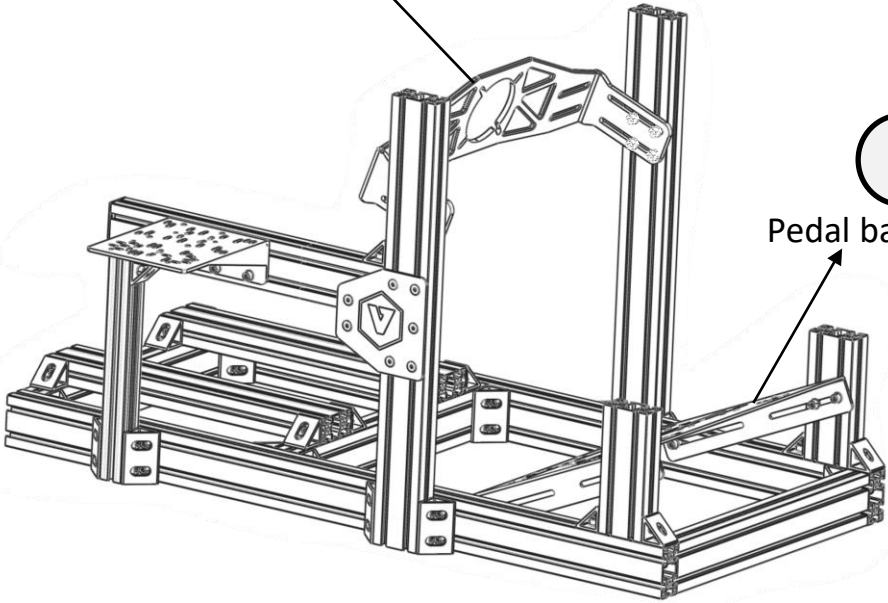

9

Pedal base plate V3

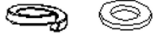

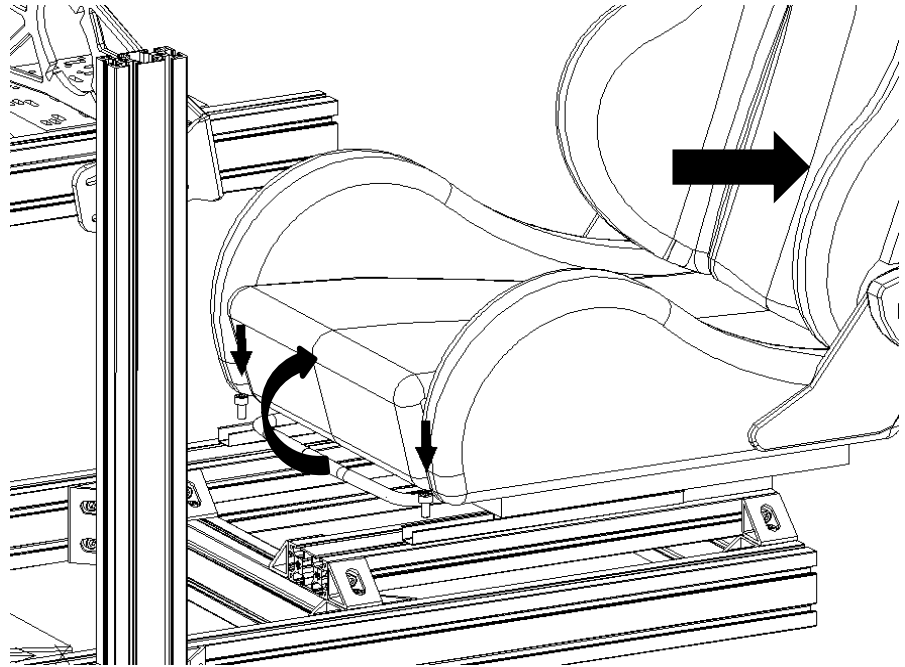
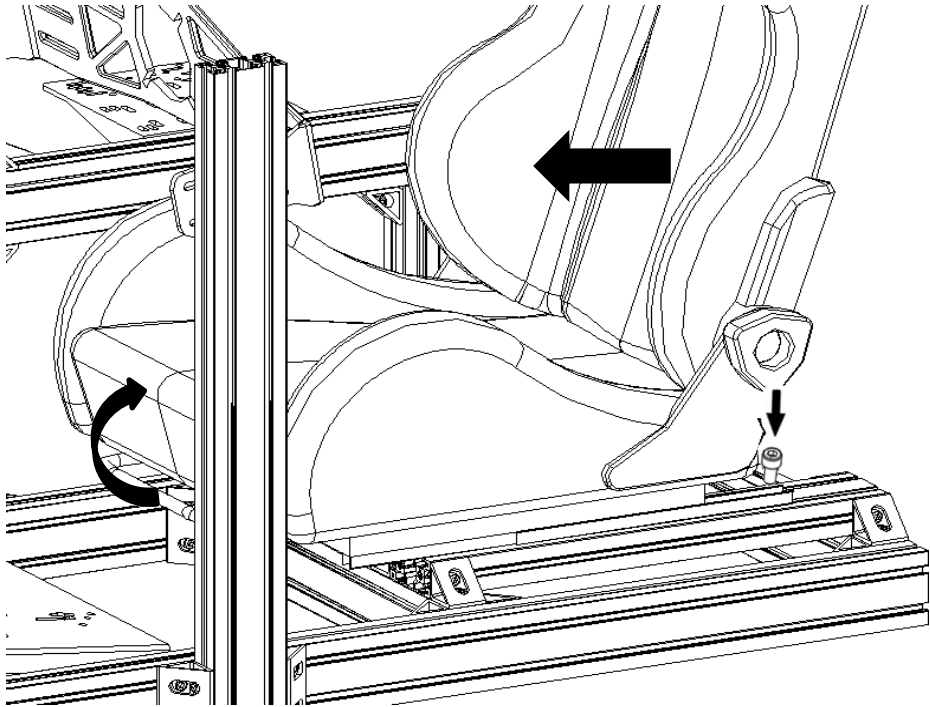
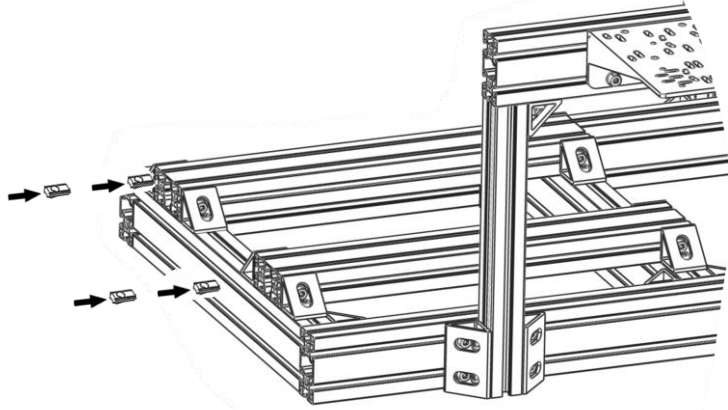
M8x16 x4	M8 Slider x4	Flat, Spring M8 x4
		



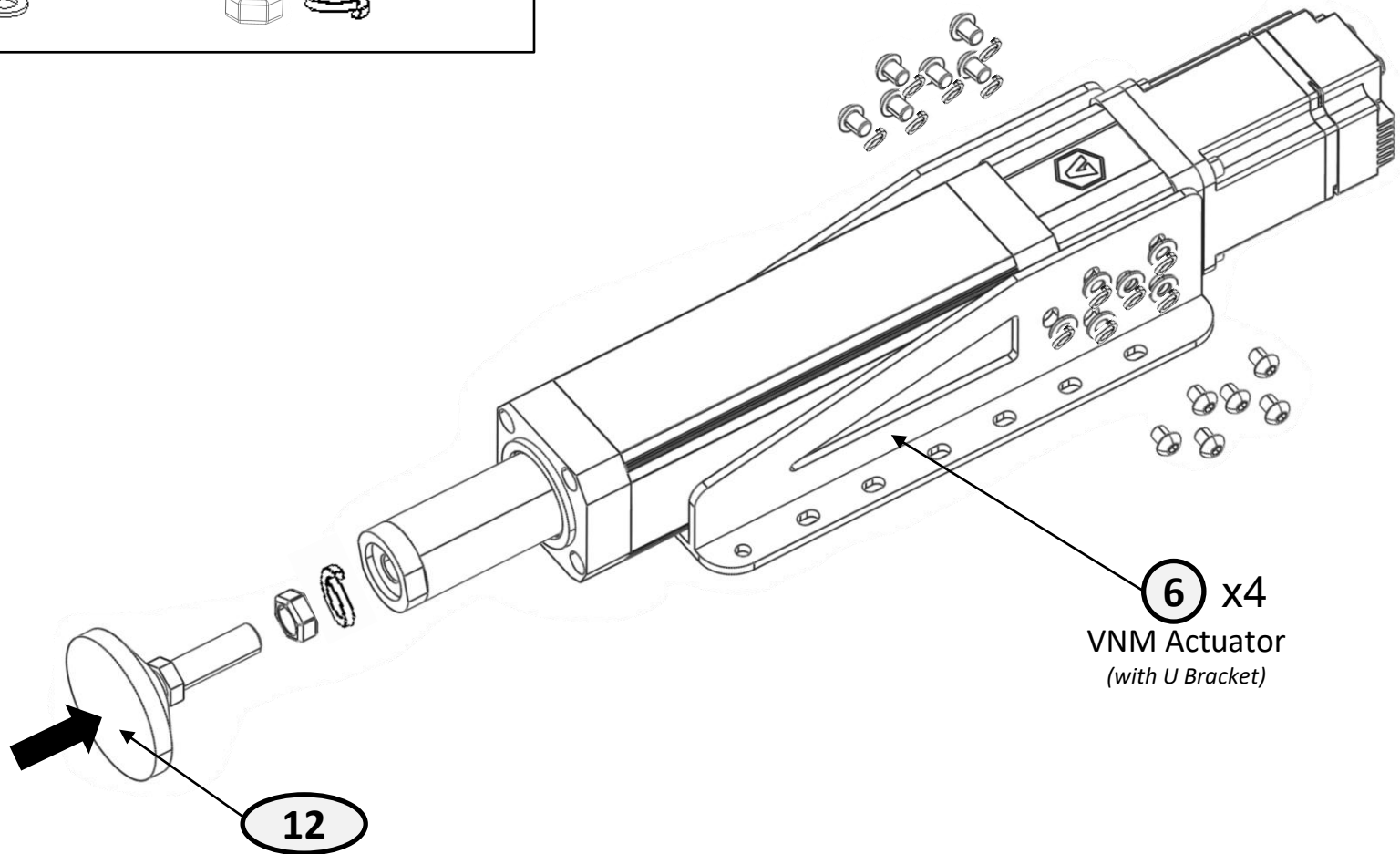

M8x16 x12	Flat, Spring M8 x12	M16 Nuts, Spring M16 x1
		



12

Feet Actuator

6 x4
VNM Actuator
(with U Bracket)

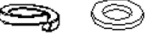
M8x16 x16	M8 Slider x16	Flat, Spring M8 x16
		

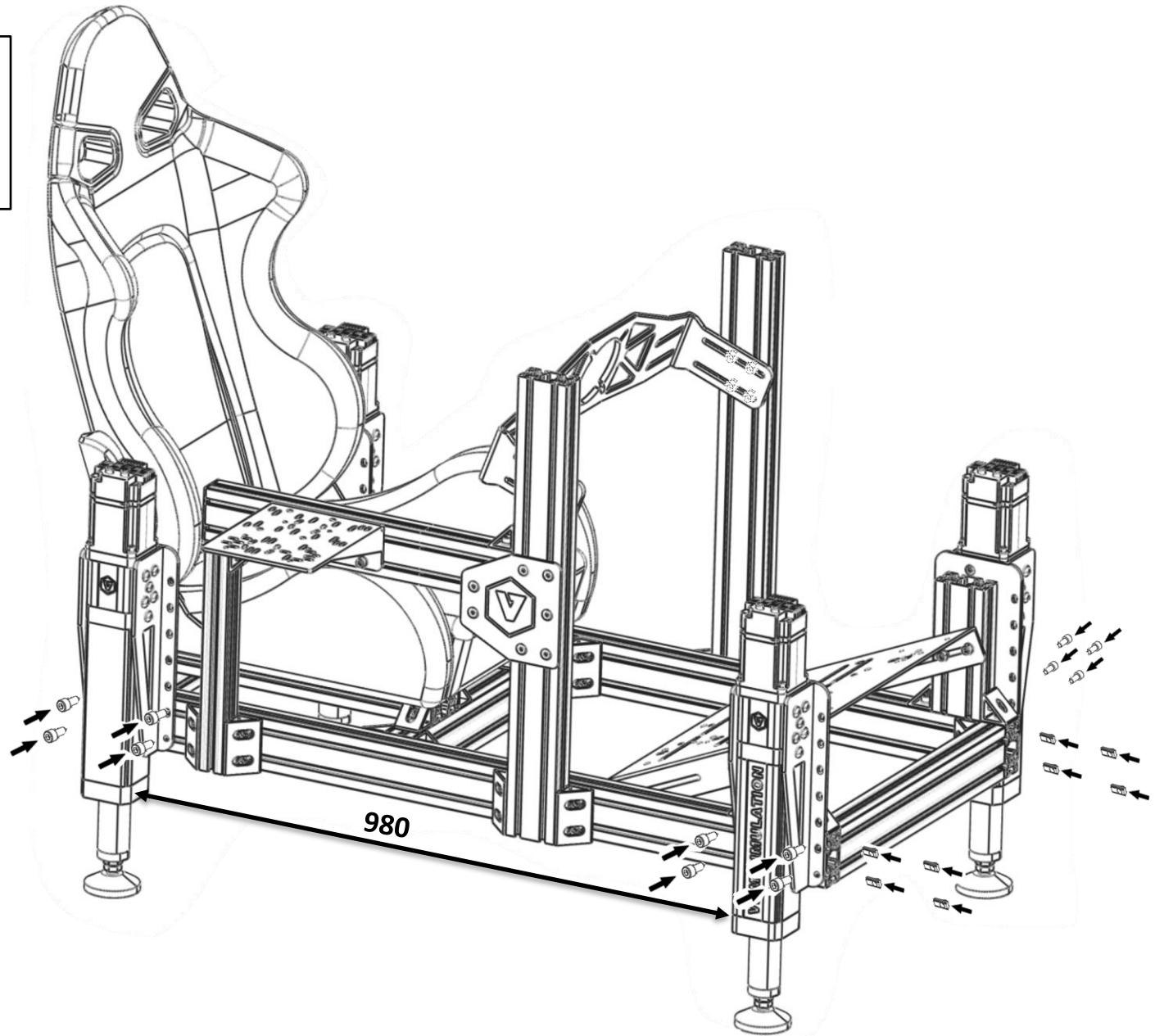

Tip: Use rigid blocks of suitable height to support the four corners of the rig for easier installation of the four VNM actuators.

Alu cover
x13

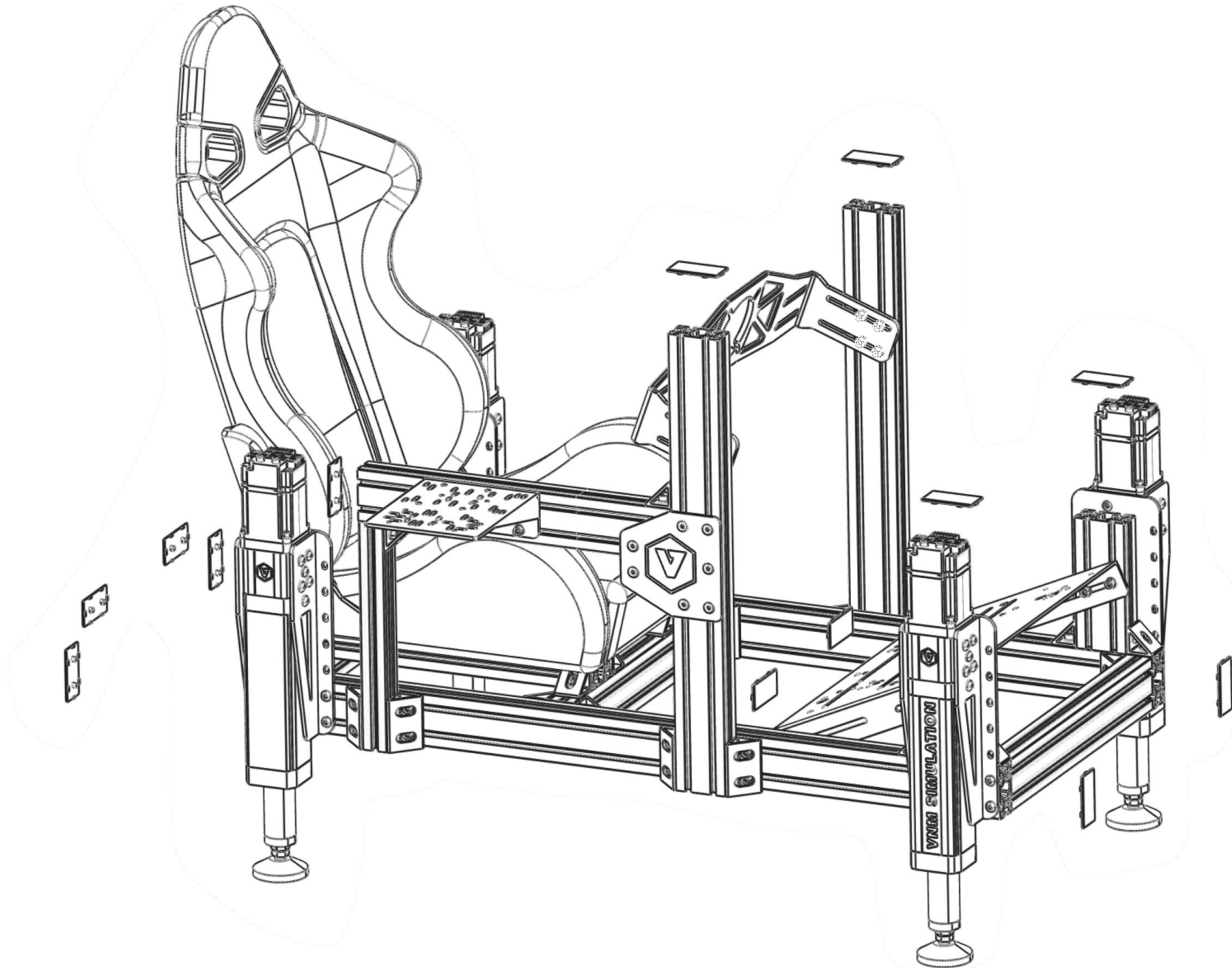

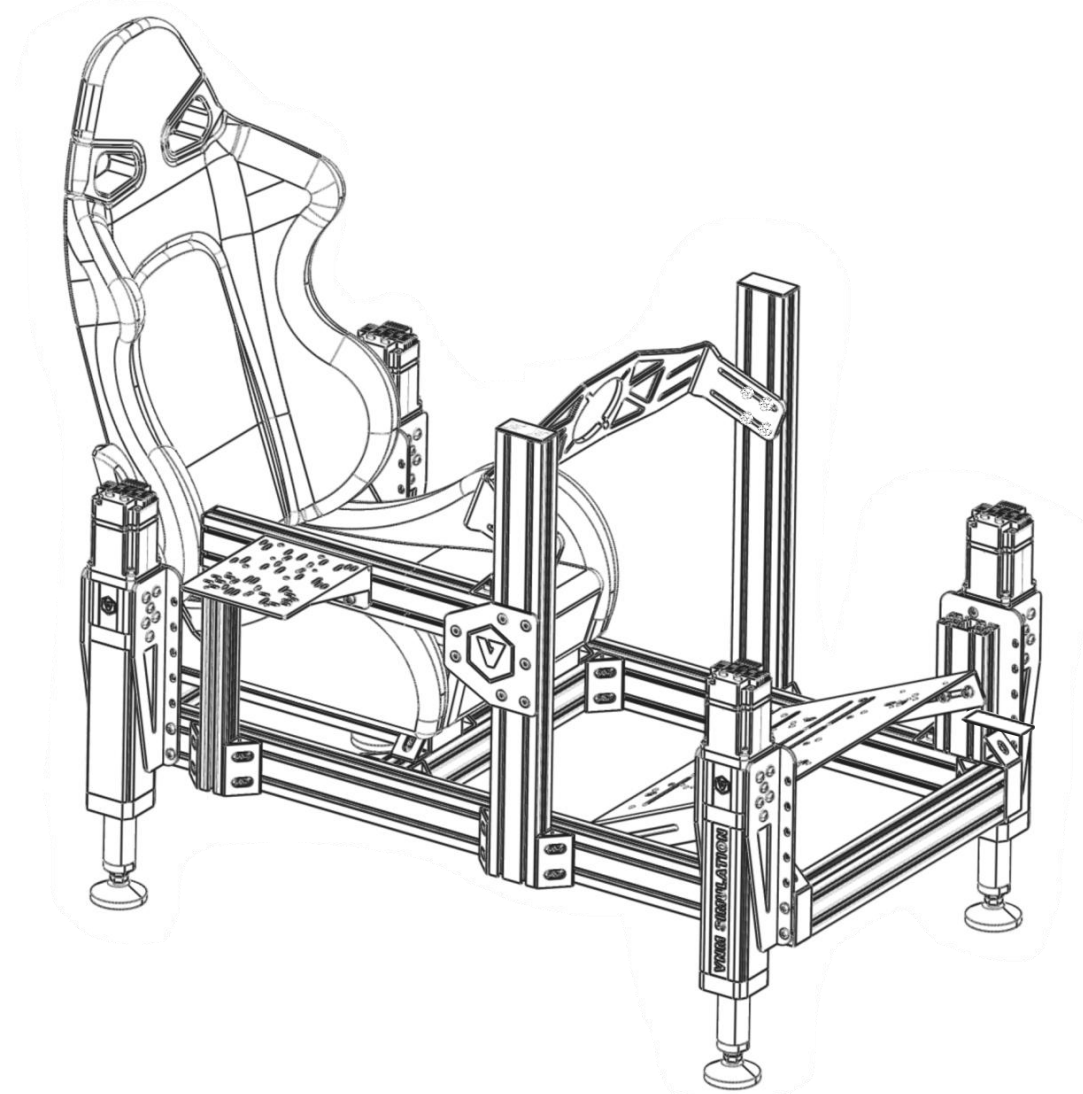

*“Congratulations on completing your rig assembly.
If you have any questions or encounter any problems, please contact us for support!”*